



AMP Series 64

HIGH-TEMPERATURE ELECTRIC DECK OVEN



Job Name	
Model	WS-HD-61-E3-L
Item#	

CONSTRUCTION

- Structure made of folded stainless steel
- Stand—painted sheet metal
- Hood—stainless steel with customizable area
- Steam duct—stainless steel plate
- Stainless steel door, tempered glass
- Aluminized steel top and side structure
- Dual halogen lighting
- Rock wool heat insulation

ELECTRICAL SPECIFICATIONS

Max power/deck kW	Electric Spec
16.9 kW	46.9 A/deck - 208 VAC, 3P

COOKING CHAMBER DIMENSIONS

Ext Dims W x D	Int Dims W x D x H	Baking Surface Area Per Deck
63 1/2" x 61"	49" x 51" x 7"	173 sq ft

NUMBER OF DECKS

(available as single, double or triple deck.)

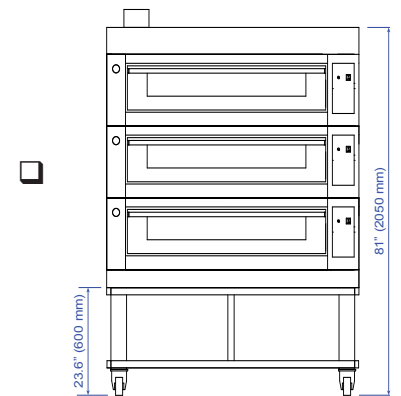
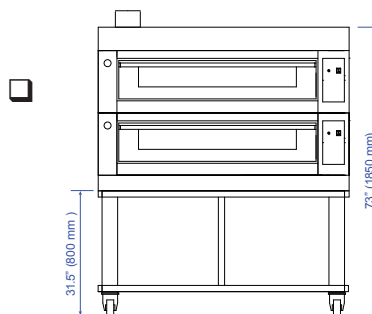
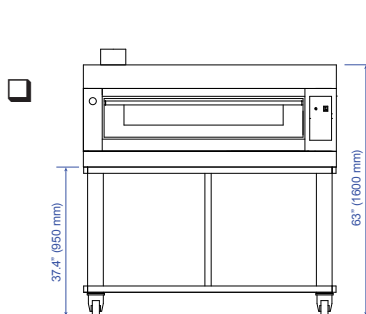

Constructed of folded stainless steel with aluminized steel top and side structure, the Electric Deck Oven combines durability with a refined, professional appearance. Its fully insulated baking chamber features a textured refractory stone deck and armored heating elements that ensure even, consistent heat above and below the baking surface.

The electronic controller provides independent top and bottom heat adjustment, 20 customizable programs, and both a timer and an "economy" mode for energy efficiency. A bottom-hinged stainless steel door with tempered glass allows full visibility during baking.

The oven reaches a maximum temperature of 850°F, suitable for any pizza style. Standard features include dual halogen lighting, a manual vapor control vent, and a stainless steel hood and stand with casters.

Its modular design allows additional decks to be added later as your operation grows.

CAPACITY (PIZZAS PER DECK)

WS-HD-61-E3-L 12" pizzas = 16, 18" pizzas = 6

The approximate maximum hourly production capacity can be calculated by multiplying the above numbers by (60 minutes / cook time in minutes). Cook times will vary depending on "style" of pizza.



t. 360.650.1111
tf. 800.988.8103
f. 360.650.1166

Wood Stone Corporation
1801 W. Bakerview Rd.
Bellingham, WA 98226 USA
info@woodstone-corp.com
woodstone-corp.com

REVISED: SPRING 2026

An ongoing program of product improvement may require us to change specifications without notice.





AMP Series 64

HIGH-TEMPERATURE ELECTRIC DECK OVEN • WS-HD-61-E3-L

A	Vent
B	Door
C	Door Handle
D	Digital Controller
E	Casters
	Electrical Connection (accessible from outside only)
F	Cooking Chamber
G	Viewing Window

PLAN VIEW

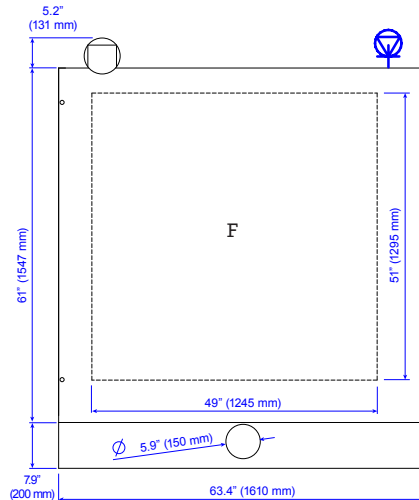

SIDE VIEW

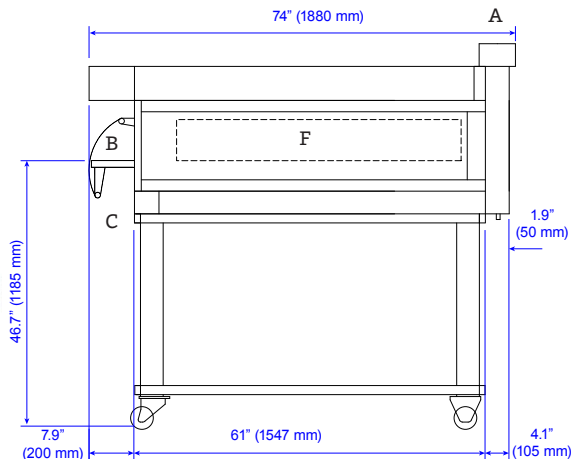

FRONT VIEW

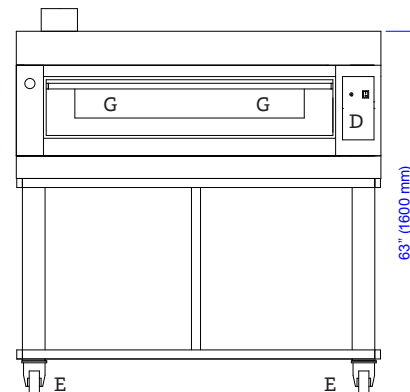

UTILITIES SPECIFICATIONS

ELECTRICAL
208 VAC, 60 Hz, 3 phase
Connection made on left side of oven as shown.

SHIP WEIGHT

ONE DECK: 873 lbs / 396 kg

VENTING INFORMATION

The AMP Series 64 is Type 2 hood compatible. Venting must comply with all applicable local and national codes—check with your local authority having jurisdiction (AHJ) before planning or construction.

ENVIRONMENTAL

WORKING TEMPERATURE:
+50°F TO 95°F (+10°C TO 35°C)

RELATIVE HUMIDITY:
15% TO 65%



t. 360.650.1111
tf. 800.988.8103
f. 360.650.1166

Wood Stone Corporation
1801 W. Bakerview Rd.
Bellingham, WA 98226 USA
info@woodstone-corp.com
woodstone-corp.com

REVISED: SPRING 2026

An ongoing program of product improvement may require us to change specifications without notice.





AMP Series 64

HIGH-TEMPERATURE ELECTRIC DECK OVEN • WS-HD-61-E3-L

A	Vent
B	Door
C	Door Handle
D	Digital Controller
E	Casters
	Electrical Connection (accessible from outside only)
F	Cooking Chamber
G	Viewing Window

PLAN VIEW

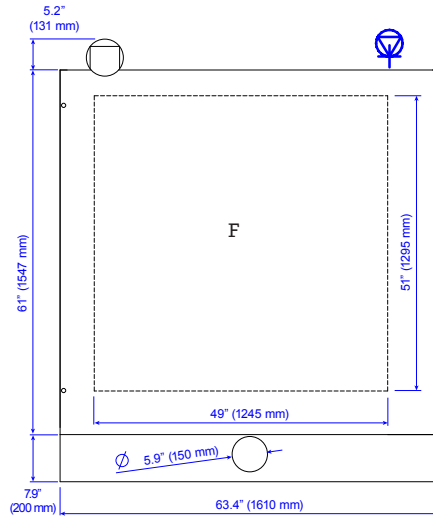

SIDE VIEW

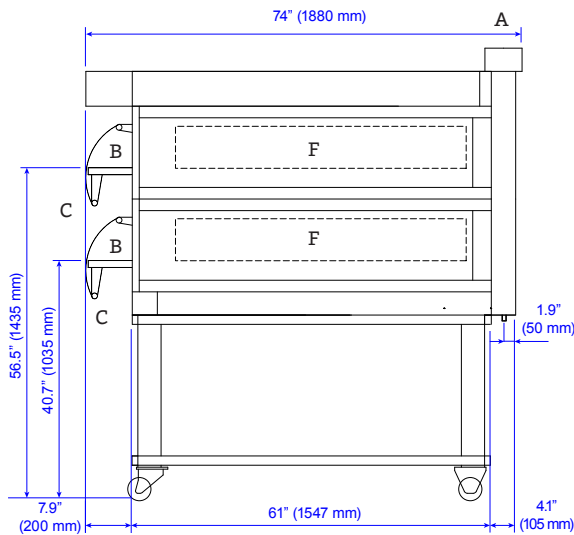

FRONT VIEW

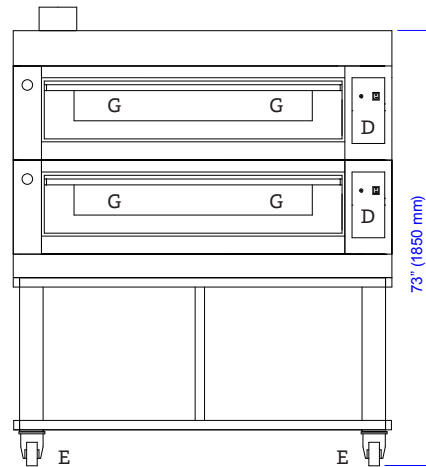

UTILITIES SPECIFICATIONS

ELECTRICAL
208 VAC, 60 Hz, 3 phase
Connection made on left side of oven as shown.

SHIP WEIGHT

TWO DECKS: 1413 lbs / 641 kg

VENTING INFORMATION

The AMP Series 64 is Type 2 hood compatible. Venting must comply with all applicable local and national codes—check with your local authority having jurisdiction (AHJ) before planning or construction.

ENVIRONMENTAL

WORKING TEMPERATURE:
+50°F TO 95°F (+10°C TO 35°C)

RELATIVE HUMIDITY:
15% TO 65%



t. 360.650.1111
tf. 800.988.8103
f. 360.650.1166

Wood Stone Corporation
1801 W. Bakerview Rd.
Bellingham, WA 98226 USA
info@woodstone-corp.com
woodstone-corp.com

REVISED: SPRING 2026

An ongoing program of product improvement may require us to change specifications without notice.





AMP Series 64

HIGH-TEMPERATURE ELECTRIC DECK OVEN • WS-HD-61-E3-L

A	Vent
B	Door
C	Door Handle
D	Digital Controller
E	Casters
	Electrical Connection (accessible from outside only)
F	Cooking Chamber
G	Viewing Window

PLAN VIEW

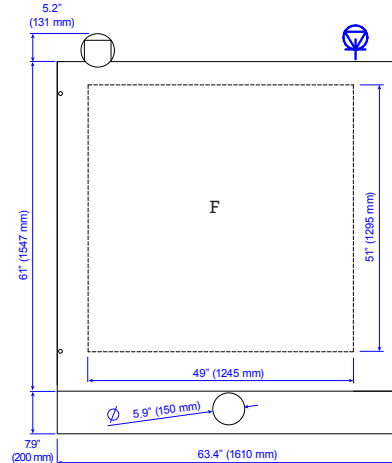

SIDE VIEW

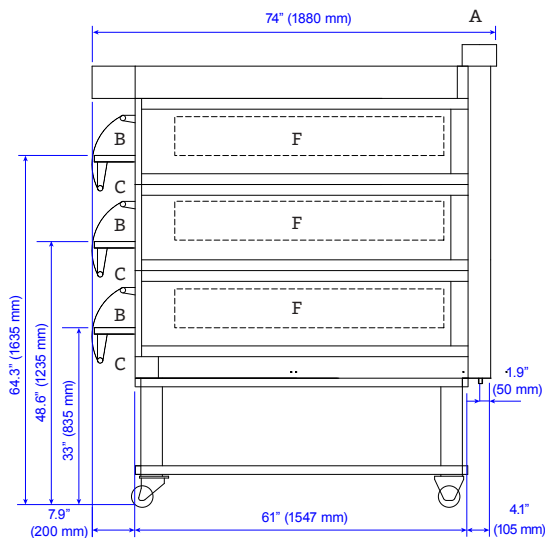

FRONT VIEW

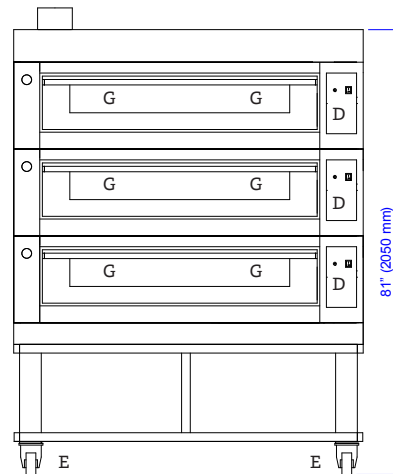

UTILITIES SPECIFICATIONS

ELECTRICAL
208 VAC, 60 Hz, 3 phase
Connection made on left side of oven as shown.

SHIP WEIGHT

THREE DECKS: 1953 lbs / 886 kg

VENTING INFORMATION

The AMP Series 64 is Type 2 hood compatible. Venting must comply with all applicable local and national codes—check with your local authority having jurisdiction (AHJ) before planning or construction.

ENVIRONMENTAL

WORKING TEMPERATURE:
+50°F TO 95°F (+10°C TO 35°C)
RELATIVE HUMIDITY:
15% TO 65%



t. 360.650.1111
tf. 800.988.8103
f. 360.650.1166

Wood Stone Corporation
1801 W. Bakerview Rd.
Bellingham, WA 98226 USA
info@woodstone-corp.com
woodstone-corp.com

REVISED: SPRING 2026

An ongoing program of product improvement may require us to change specifications without notice.

