



# AMP Series 64

HIGH-TEMPERATURE ELECTRIC DECK OVEN



Job Name

Model

WS-HD-37-E3-L

Item#

Constructed of folded stainless steel with aluminized steel top and side structure, the Electric Deck Oven combines durability with a refined, professional appearance. Its fully insulated baking chamber features a textured refractory stone deck and armored heating elements that ensure even, consistent heat above and below the baking surface.

The electronic controller provides independent top and bottom heat adjustment, 20 customizable programs, and both a timer and an "economy" mode for energy efficiency. A bottom-hinged stainless steel door with tempered glass allows full visibility during baking.

The oven reaches a maximum temperature of 850°F, suitable for any pizza style. Standard features include dual halogen lighting, a manual vapor control vent, and a stainless steel hood and stand with casters.

Its modular design allows additional decks to be added later as your operation grows.

## CONSTRUCTION

Structure made of folded stainless steel

Stand—painted sheet metal

Hood—stainless steel with customizable area

Steam duct—stainless steel plate

Stainless steel door, tempered glass

Aluminized steel top and side structure

Dual halogen lighting

Rock wool heat insulation

## ELECTRICAL SPECIFICATIONS

Max power/deck kW	Electric Spec
9.4 kW	26.1 A/deck - 208 VAC, 3P

## COOKING CHAMBER DIMENSIONS

Ext Dims W x D	Int Dims W x D x H	Baking Surface Area Per Deck
63 1/2" x 37 1/4"	49" x 25 1/2" x 7"	8.6 sq ft

## CAPACITY (PIZZAS PER DECK)

WS-HD-37-E3-L      12" pizzas = 8, 18" pizzas = 2

*The approximate maximum hourly production capacity can be calculated by multiplying the above numbers by (60 minutes / cook time in minutes). Cook times will vary depending on "style" of pizza.*

## NUMBER OF DECKS

(available as single, double or triple deck.)

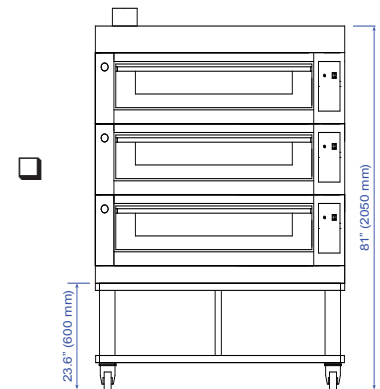
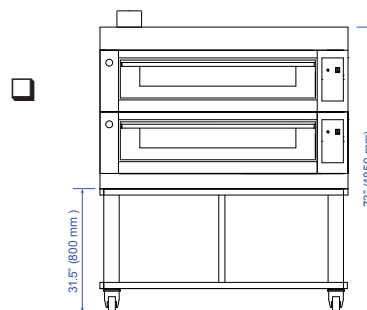
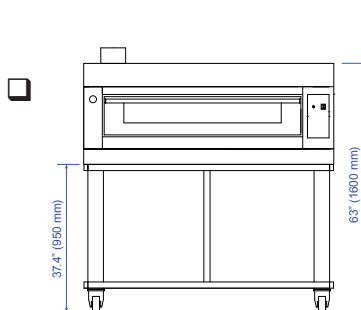

t. 360.650.1111  
tf. 800.988.8103  
f. 360.650.1166

Wood Stone Corporation  
1801 W. Bakerview Rd.  
Bellingham, WA 98226 USA  
info@woodstone-corp.com  
woodstone-corp.com

REVISED: SPRING 2026

An ongoing program of product improvement may require us to change specifications without notice.

WOOD  STONE



# AMP Series 64

HIGH-TEMPERATURE ELECTRIC DECK OVEN • WS-HD-37-E3-L

A	Vent
B	Door
C	Door Handle
D	Digital Controller
E	Casters
	Electrical Connection (accessible from outside only)
F	Cooking Chamber
G	Viewing Window

PLAN VIEW

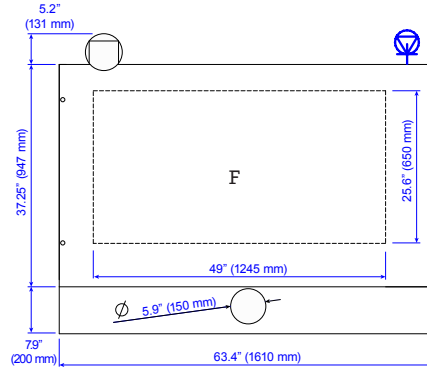

SIDE VIEW

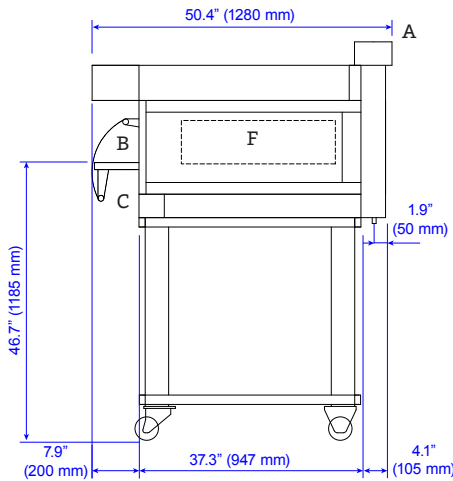

FRONT VIEW

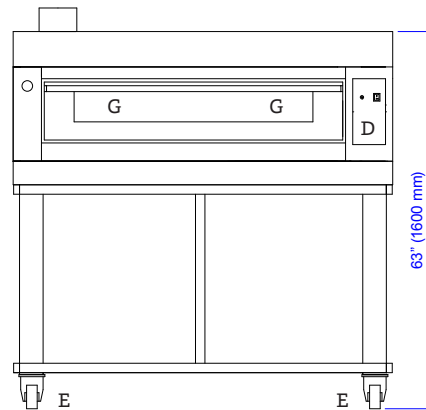

UTILITIES SPECIFICATIONS

**ELECTRICAL**  
208 VAC, 60 Hz, 3 phase  
Connection made on left side of oven as shown.

SHIP WEIGHT

ONE DECK: 633 lbs / 287 kg

VENTING INFORMATION

The AMP Series 64 is Type 2 hood compatible. Venting must comply with all applicable local and national codes—check with your local authority having jurisdiction (AHJ) before planning or construction.

ENVIRONMENTAL

**WORKING TEMPERATURE:**  
+50°F TO 95°F (+10°C TO 35°C)  
**RELATIVE HUMIDITY:**  
15% TO 65%



t. 360.650.1111  
tf. 800.988.8103  
f. 360.650.1166

Wood Stone Corporation  
1801 W. Bakerview Rd.  
Bellingham, WA 98226 USA  
[info@woodstone-corp.com](mailto:info@woodstone-corp.com)  
[woodstone-corp.com](http://woodstone-corp.com)

REVISED: SPRING 2026

An ongoing program of product improvement may require us to change specifications without notice.





# AMP Series 64

HIGH-TEMPERATURE ELECTRIC DECK OVEN • WS-HD-37-E3-L

A	Vent
B	Door
C	Door Handle
D	Digital Controller
E	Casters
	Electrical Connection (accessible from outside only)
F	Cooking Chamber
G	Viewing Window

## PLAN VIEW

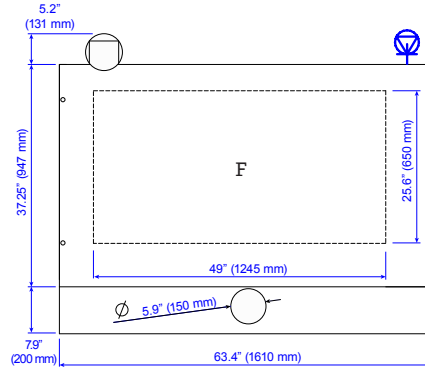

## SIDE VIEW

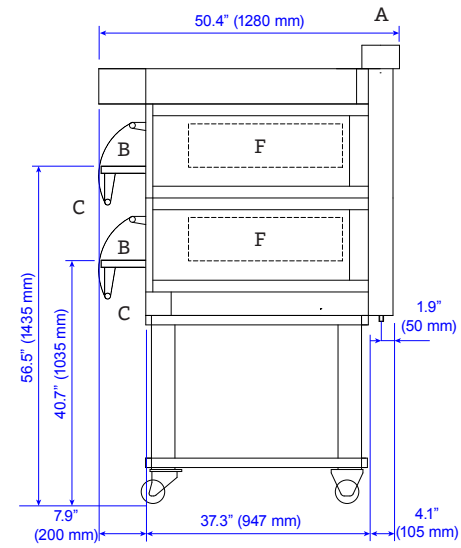

## FRONT VIEW

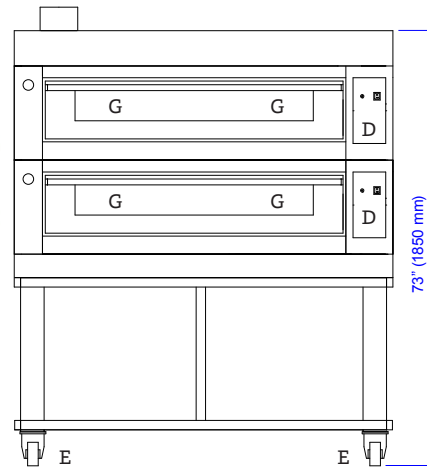

### UTILITIES SPECIFICATIONS

**ELECTRICAL**  
208 VAC, 60 Hz, 3 phase  
Connection made on left side of oven as shown.

### SHIP WEIGHT

TWO DECKS: 1010 lbs / 458 kg

### VENTING INFORMATION

The AMP Series 64 is Type 2 hood compatible. Venting must comply with all applicable local and national codes—check with your local authority having jurisdiction (AHJ) before planning or construction.

### ENVIRONMENTAL

**WORKING TEMPERATURE:**  
+50°F TO 95°F (+10°C TO 35°C)  
**RELATIVE HUMIDITY:**  
15% TO 65%



t. 360.650.1111  
tf. 800.988.8103  
f. 360.650.1166

Wood Stone Corporation  
1801 W. Bakerview Rd.  
Bellingham, WA 98226 USA  
[info@woodstone-corp.com](mailto:info@woodstone-corp.com)  
[woodstone-corp.com](http://woodstone-corp.com)

REVISED: SPRING 2026

An ongoing program of product improvement may require us to change specifications without notice.





# AMP Series 64

HIGH-TEMPERATURE ELECTRIC DECK OVEN • WS-HD-37-E3-L

A	Vent
B	Door
C	Door Handle
D	Digital Controller
E	Casters
	Electrical Connection (accessible from outside only)
F	Cooking Chamber
G	Viewing Window

PLAN VIEW

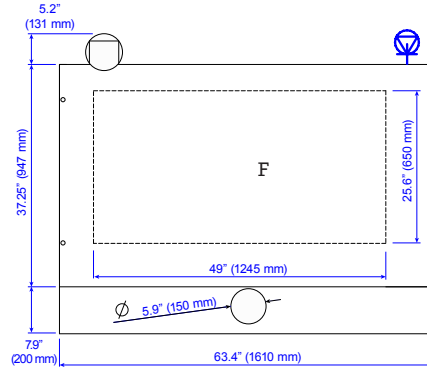

SIDE VIEW

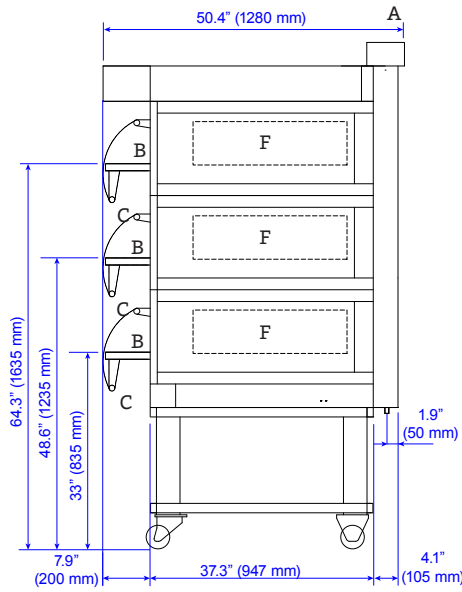

FRONT VIEW

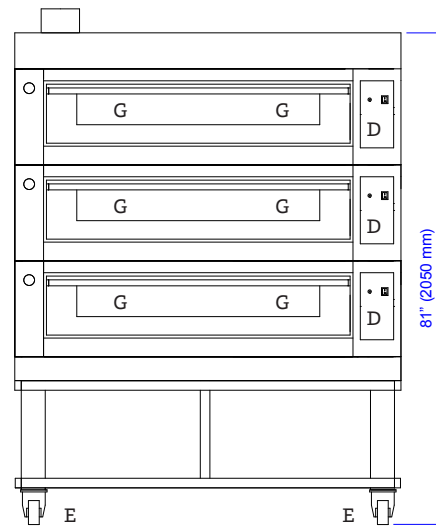

UTILITIES SPECIFICATIONS

**ELECTRICAL**  
208 VAC, 60 Hz, 3 phase  
Connection made on left side of oven as shown.

SHIP WEIGHT

THREE DECKS: 1387 lbs / 629 kg

VENTING INFORMATION

The AMP Series 64 is Type 2 hood compatible. Venting must comply with all applicable local and national codes—check with your local authority having jurisdiction (AHJ) before planning or construction.

ENVIRONMENTAL

**WORKING TEMPERATURE:**  
+50°F TO 95°F (+10°C TO 35°C)  
**RELATIVE HUMIDITY:**  
15% TO 65%



t. 360.650.1111  
tf. 800.988.8103  
f. 360.650.1166

Wood Stone Corporation  
1801 W. Bakerview Rd.  
Bellingham, WA 98226 USA  
[info@woodstone-corp.com](mailto:info@woodstone-corp.com)  
[woodstone-corp.com](http://woodstone-corp.com)

REVISED: SPRING 2026

An ongoing program of product improvement may require us to change specifications without notice.

