

Prep for Moving OneRev Through 72 Inch Doorway

With temporary caster installation instructions



ONEREV

Rotating Oven

Gas-Fired

ONEREV WS-RV-7880

WOOD  STONE

WOOD STONE CORPORATION

1801 W. Bakerview Rd.
Bellingham, WA 98226 USA

Toll Free 800.988.8103

Tel 360.650.1111

Fax 360.650.1166

www.woodstone-corp.com

REVISED **AUGUST 2024**



PURPOSE OF THESE INSTRUCTIONS

These instructions show how to remove protruding components from the front of the oven and install temporary casters that will allow you to roll the oven through a 72" opening.



TOOLS NEEDED

- 7/16 Nut Driver
- 7/16 deep well socket or socket with extension
- Phillips Head Screw Driver
- 7/16 Wrench

PARTS NEEDED

- Caster Kit

Be sure to retain all hardware that is removed as it will be used for reinstalling components.

1: REMOVE THE LOGO PANEL

Lift it up and toward yourself.

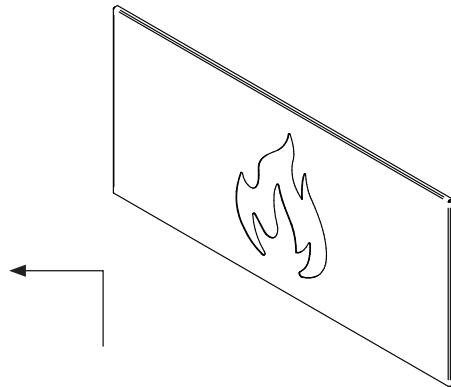

2: REMOVE THE DEBRIS MANTEL

Remove the crumb tray and cover plate (by lifting it up and pulling toward yourself) and set them aside.





REMOVE DEBRIS MANTEL (CONTINUED)

Use a Phillips head driver to remove the two screws holding the cowling in place.

Undo the four bolts on the left and right of the debris mantel. Be mindful of the washer on each bolt.

Remove the debris mantel assembly and set it aside.



REVISED AUGUST 2024

An ongoing program of product improvement may require us to change specifications without notice.

WOOD STONE CORPORATION

1801 W. Bakerview Rd.
Bellingham, WA 98226 USA

TOLL FREE 800.988.8103

TEL 360.650.1111

FAX 360.650.1166

E-MAIL info@woodstone-corp.com

woodstone-corp.com



3: REMOVE CONTROL UNIT COVER PLATE

Unscrew the Phillips head screws holding the metal cover plate on the control panel and lower it away.

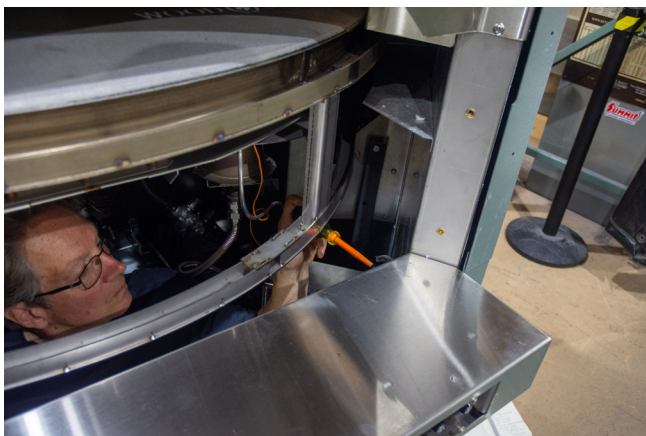



4: REMOVE CONTROL UNIT

Undo the bolts holding the control unit. Keep electrical connections. Place the unit inside the oven.

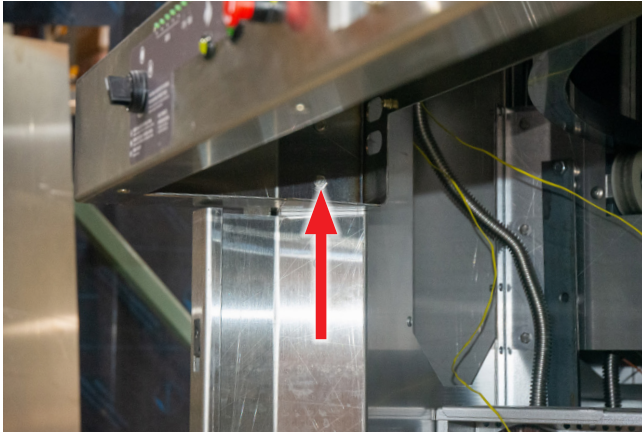

5: REMOVE THREE PIECES OF COMBING

Sides and bottom. Remove #3 Phillips screws and remove the combing.



REVISED AUGUST 2024

An ongoing program of product improvement may require us to change specifications without notice.

WOOD STONE CORPORATION
1801 W. Bakerview Rd.
Bellingham, WA 98226 USA

TOLL FREE 800.988.8103
TEL 360.650.1111
FAX 360.650.1166

E-MAIL info@woodstone-corp.com
woodstone-corp.com



6: INSTALL CASTERS

IMPORTANT: Using a pallet jack or forklift, lift the oven up and slide two two-by-fours, the length of the oven, underneath the left and right sides of the oven. Lower the oven onto the two-by-fours. **DO NOT install the casters while the oven is lifted by any other means.**

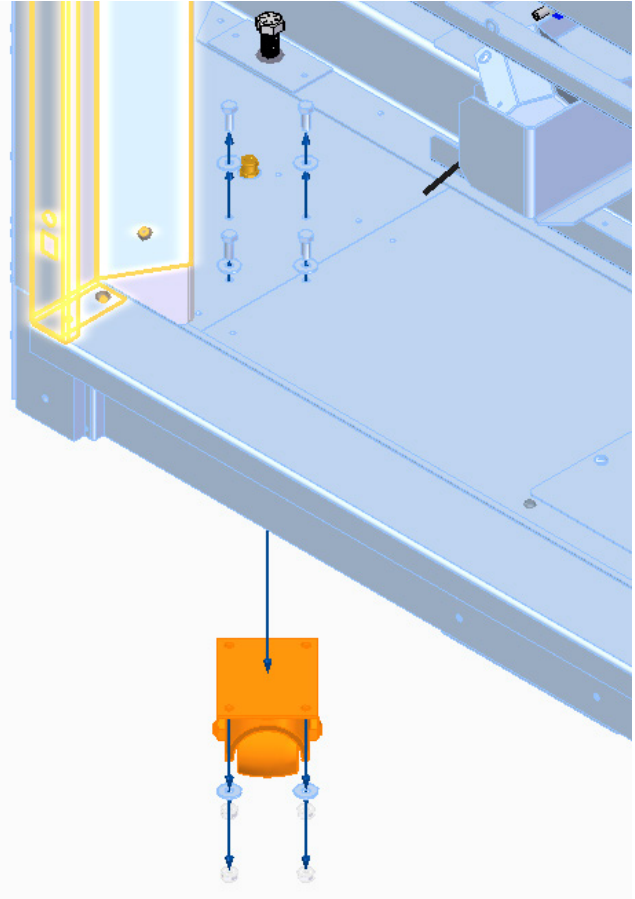
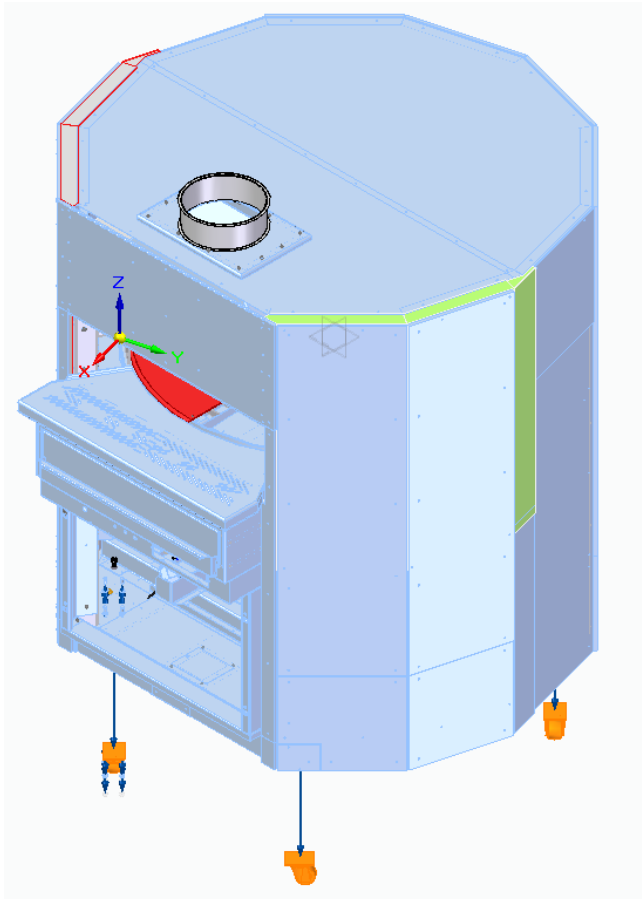

Mount the casters on the fork tubes leaving the pallet fork tubes open.

Insert the four 1" long 1/4-20 bolts from the underside. The washers go on top and bottom. Secure with nut and tighten appropriately.



INSTALL CASTERS (CONTINUED)

Caster placement.

