



WS-FD-11290-RFG-LL-IR-CL configuration shown
(coal burns on right).

Job Name	
Model	WS-FD-11290-CL
Item#	

The Coal-Fired Fire Deck 11290 oven features a door opening 60 inches wide x 10 inches high. The cooking surface is 79 inches wide x 78 inches deep, resulting in a 43-square-foot cooking surface. The oven has been designed to achieve an excellent balance of top and bottom heat while burning coal. It incorporates an air plenum beneath the deck, enabling efficient combustion of the coal. This model utilizes two radiant flame (RFG) burners on one side of the oven opposite the coal fire, and a thermostatically controlled gas Underfloor Infrared (IR) burner beneath the oven deck.

A tensioned steel exoskeleton surrounding the hearth and dome perimeter ensures structural integrity and longevity. Wrapped in spun ceramic fiber insulation and requiring only 1-inch side clearance to combustibles, the monolithic cast-ceramic 6-inch thick hearth and monolithic 4-inch thick dome rest on a painted black steel stand. The oven body front, top, back and sides are finished with galvanized steel.

The oven arrives completely assembled, ETL Listed, ready to install and is made in the USA. A set of casters ship on the oven to assist with installation (remove once installed). Information about custom finishes, tools and accessories can be found online at: woodstone-corp.com.

HEARTH CAPACITY

8" pizzas:	56
10" pizzas:	42
12" pizzas:	30
16" pizzas:	16
18" pizzas:	12

Assuming 5-minute cook times, the approximate maximum hourly production capacity can be calculated by multiplying the above numbers by 12. Cook times will also vary depending on "style" of pizza.

FEATURES

- Rectangular Footprint
- Visible Flame
- High Production
- Coal and Gas-Fired
- Underfloor Infrared (IR) Burner
- Low Arch Wide
- Facade Friendly

GUIDE TO MODEL NUMBERS*

	Underfloor IR Burner	Left Side Radiant Flame Right Side Coal	Right Side Radiant Flame Left Side Coal	Natural Gas	Liquid Propane
WS-FD-11290-RFG-LL-IR-CL	X	2		-NG	-LP
WS-FD-11290-RFG-RR-IR-CL	X		2	-NG	-LP

*Model number indicates the location of the radiant flame. Coal will burn opposite the gas flame.



t. 360.650.1111
tf. 800.988.8103
f. 360.650.1166

Wood Stone Corporation
1801 W. Bakerview Rd.
Bellingham, WA 98226 USA
info@woodstone-corp.com
woodstone-corp.com

REVISED: SPRING 2026

An ongoing program of product improvement may require us to change specifications without notice.



COAL-FIRED OVEN

STONE HEARTH OVEN • WS-FD-11290-CL

VERY IMPORTANT!!

Oven is shipped with casters. Height with casters to the top of the flue collar is 87-3/4". Once the oven is in place the casters must be removed. Utility connections are made underneath the oven; they are shown on the plan view to illustrate geographic location only.

A	Flue Collar
B	Mantel
C	Flame Height Control Knob
D	Digital Controller
E	Forklift Pockets
	Electrical Connection
F	Service Panel or Optional Storage Box
	Gas Connection
H	Ash Chute
I	Coal Blower Fan Control
	Must Be Left Removable for Service
	AIR INTAKE: Do Not Facade or Cover Over

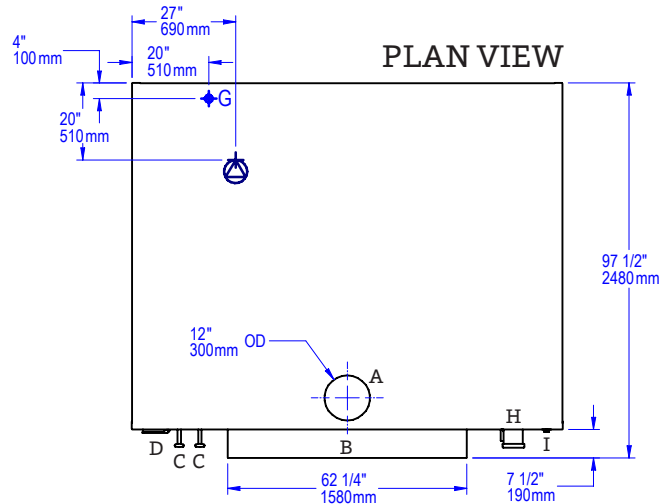

SIDE VIEW

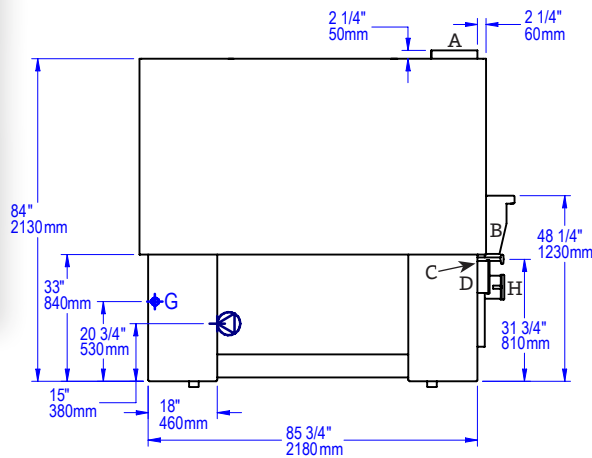

FRONT VIEW

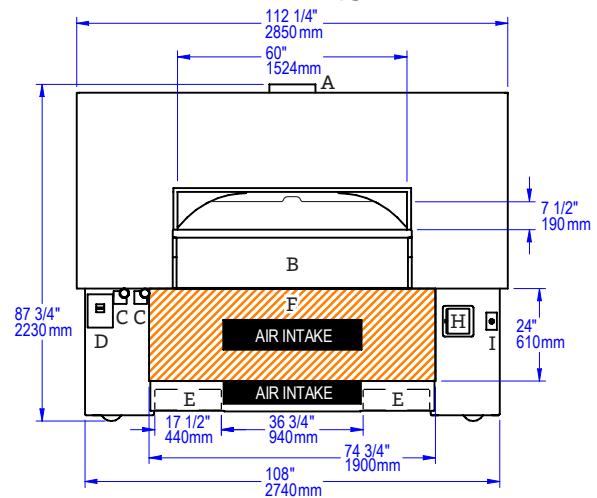

UTILITIES SPECIFICATIONS

GAS
Gas and Coal
 1 inch gas inlet (FNPT)
 343,000 BTU/hr - Natural Gas (NG)
 OR
 365,000 BTU/hr - Propane (LP)

ELECTRICAL
 120 VAC, 4 A, 50/60 Hz
 Connection made underneath oven.

IMPORTANT: Models with -CL in the model number must be vented as a solid fuel appliance.

VENTING INFORMATION

The Fire Deck 11290-CL can be direct connected to a power-ventilated, grease-rated chimney or be vented using a Listed Type 1 exhaust hood, or a hood constructed and installed in accordance with NFPA 96 and all relevant local and national codes. This model must be vented as a solid fuel appliance. The oven must be vented in accordance with all relevant local and national codes, and in a manner acceptable to the authority having jurisdiction.

Ship Weight: 11,500 lbs / 5,216 kg

	BTU Output Per Burner	
Radiant Flame Burner	123,000 NG	140,000 LP
IR Burner	100,000 NG	100,000 LP



t. 360.650.1111
 tf. 800.988.8103
 f. 360.650.1166

Wood Stone Corporation
 1801 W. Bakerview Rd.
 Bellingham, WA 98226 USA
info@woodstone-corp.com
woodstone-corp.com

REVISED: SPRING 2026

An ongoing program of product improvement may require us to change specifications without notice.

