



model shown with optional eyebrow hood.

ONE REV ELECTRIC ROTATING OVEN



Job Name	
Model	WS-ERV-71-E
Item#	

The Electric OneRev oven features an arched door opening 29.5 inches wide by 6.75 inches high. The oven floor has a 15.3-square-foot cooking surface. Wood Stone's new Responsive Cooking Surface features a metal core with a proprietary ceramic coating. The ERV oven has set and forget controls that allow you to choose from 90 seconds to 6 minutes one rotation cooking, with individual controls for top and bottom heat. It comes standard with a stainless-steel debris management mantel, and the double-layered insulated walls require only a 1-inch side clearance to combustibles. The oven arrives completely assembled, ready to install, and is made in the USA by employee-owners.

FUEL CONFIGURATIONS

ELECTRIC ONLY

HEARTH CAPACITY

8" pizzas:	16
12" pizzas:	11
16" pizzas:	7

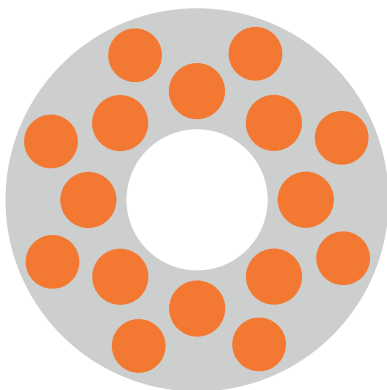

16 - 8"

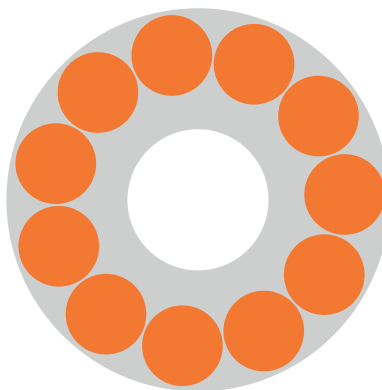

11 - 12"

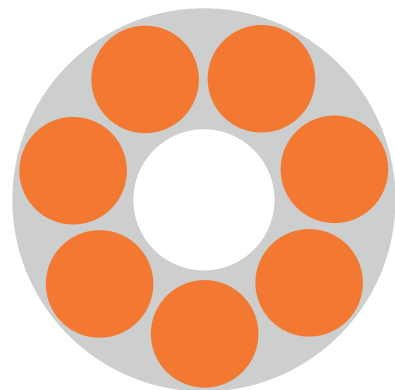

7 - 16"

Assuming 3.5-minute cook times, the approximate maximum hourly production capacity can be calculated by multiplying the above numbers by 17. Cook times will also vary depending on "style" of pizza.

t. 360.650.1111
tf. 800.988.8103
f. 360.650.1166

Wood Stone Corporation
1801 W. Bakerview Rd.
Bellingham, WA 98226 USA
info@woodstone-corp.com
woodstone-corp.com

REVISED: SPRING 2026

An ongoing program of product improvement may require us to change specifications without notice.



ONE REV

ELECTRIC ROTATING OVEN • WS-ERV-71-E
BASE CONFIGURATION

A	Flue Collar
B	Mantel
C	Control Panel
D	Function Switch
E	Casters
	Electrical Connection
F	Service Panel
G	Arch
	Must Be Left Removable for Service

PLAN VIEW

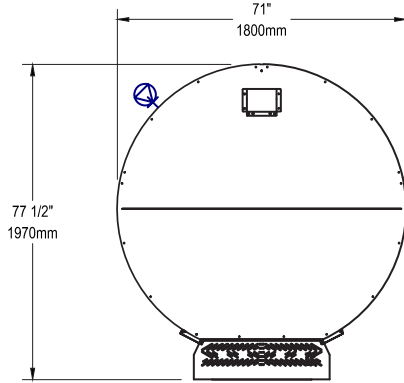

RIGHT SIDE VIEW

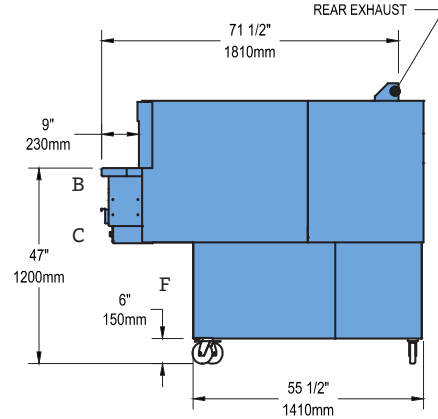

FRONT VIEW

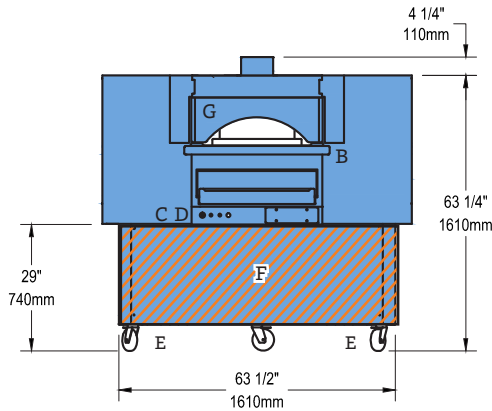

LEFT SIDE VIEW

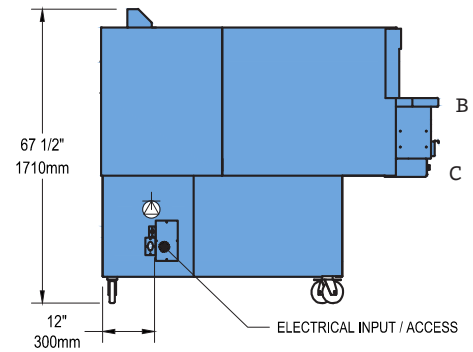

UTILITIES SPECIFICATIONS

ELECTRICAL
Model WS-ERV-71-03 : 208 VAC 3P 20.1 kW 56 A
Model WS-ERV-71-04: 240 VAC 3P 27.4 kW 66 A

VENTING INFORMATION

The OneRev Rotating Oven with the optional eyebrow hood added can be direct connected to a power-ventilated, grease-rated chimney or can be vented with a Listed Type 1 exhaust hood, or one constructed in accordance with NFPA 96 and all relevant local and national codes. The oven must be vented in accordance with all relevant local and national codes, and in a manner acceptable to the authority having jurisdiction.

With direct connect: 250 CFM with .1" WC static pressure. 6" ID flue collar (only applies if optional eyebrow hood—WS-ERV-7-EXB—is added.)

Ship Weight: 1,600 lbs / 726 kg

Wood Stone Corporation
1801 W. Bakerview Rd.
Bellingham, WA 98226 USA
info@woodstone-corp.com
woodstone-corp.com

t. 360.650.1111
tf. 800.988.8103
f. 360.650.1166

REVISED: SPRING 2026

An ongoing program of product improvement may require us to change specifications without notice.





ONE REV
 ELECTRIC ROTATING OVEN • WS-ERV-71-E
 WITH OPTIONAL EYEBROW HOOD • WS-ERV-71-XEB

A	Flue Collar
B	Mantel
C	Control Panel
D	Function Switch
E	Casters
	Electrical Connection
F	Service Panel
G	Arch
	Must Be Left Removable for Service

PLAN VIEW

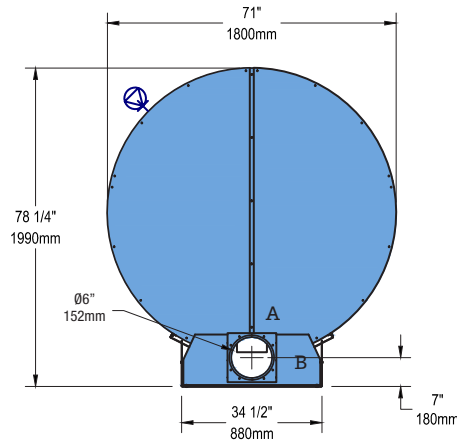

RIGHT SIDE VIEW

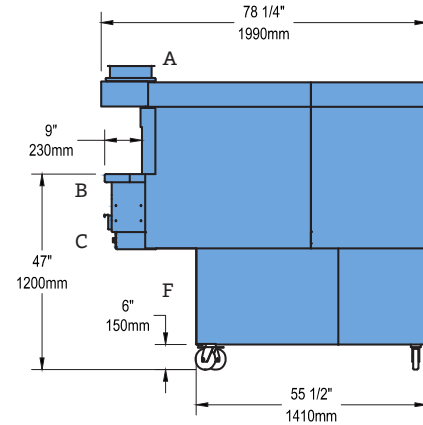

FRONT VIEW

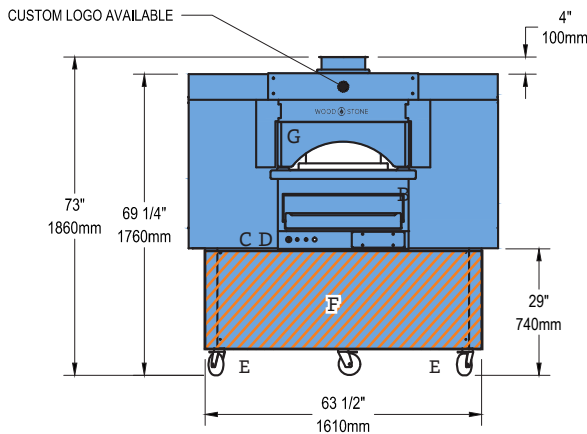

LEFT SIDE VIEW

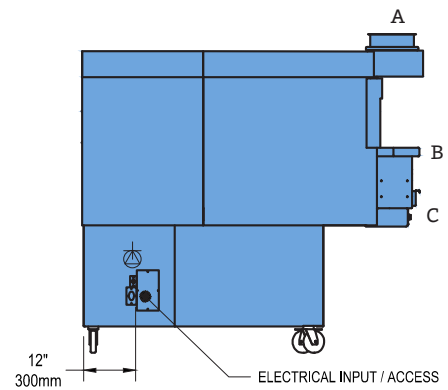

UTILITIES SPECIFICATIONS

ELECTRICAL

Model WS-ERV-71-03 : 208 VAC 3P 20.1 kW 56 A
 Model WS-ERV-71-04 : 240 VAC 3P 27.4 kW 66 A

VENTING INFORMATION

The OneRev Rotating Oven with the optional eyebrow hood added can be direct connected to a power-ventilated, grease-rated chimney or can be vented with a Listed Type 1 exhaust hood, or one constructed in accordance with NFPA 96 and all relevant local and national codes. The oven must be vented in accordance with all relevant local and national codes, and in a manner acceptable to the authority having jurisdiction.

With direct connect: 250 CFM with .1" WC static pressure. 6" ID flue collar (only applies if optional eyebrow hood—WS-ERV-7-EXB—is added.)

Ship Weight: 1,600 lbs / 726 kg

REVISED: SPRING 2026

An ongoing program of product improvement may require us to change specifications without notice.



Wood Stone Corporation
 1801 W. Bakerview Rd.
 Bellingham, WA 98226 USA
 info@woodstone-corp.com
 woodstone-corp.com

t. 360.650.1111
 tf. 800.988.8103
 f. 360.650.1166



Cancer and Reproductive Harm - www.P65Warnings.ca.gov