

Installation and Operation Manual



WHATCOM - CE

Rotisserie

*Gas-Fired Vertical, Stand and
Countertop Models, European Models*

WHATCOM GAS VERTICAL ROTISSERIE

WS-GVR-(6,10)-CE-(NG, LP)

WS-GVR-(6,10)-(DD)-(CT)-CE-(NG, LP)

WOOD  **STONE**

WOOD STONE CORPORATION

1801 W. Bakerview Rd.
Bellingham, WA 98226 USA

Tel +1.360.650.1111
Fax +1.360.650.1166



TABLE OF CONTENTS

Whatcom Vertical Rotisserie CE . . . 3
Cautions & Warnings 4
GVR Specifications 6
GVR-CT Specifications 7
Installation Clearances 8
Installation 9
Utilities10
Venting11
Gas Specifications12
Components Schematic.14
Controls15
Operation16
Cleaning17
Maintenance19
Optional Smoker Tray20
Electrical Diagrams21
Limited Warranty23



**INSTALLATION AND OPERATION MANUAL FOR THE
WOOD STONE WHATCOM VERTICAL ROTISSERIE**

ORIGINAL INSTRUCTIONS

GAS-FIRED ROTISSERIE

GVR-(6,10)-(DD)-(CT)-CE-(NG, LP)

CE MODELS

FREE-STANDING & COUNTERTOP MODELS

ADDITIONAL COPIES AVAILABLE UPON REQUEST



Shown: GVR-10-CE

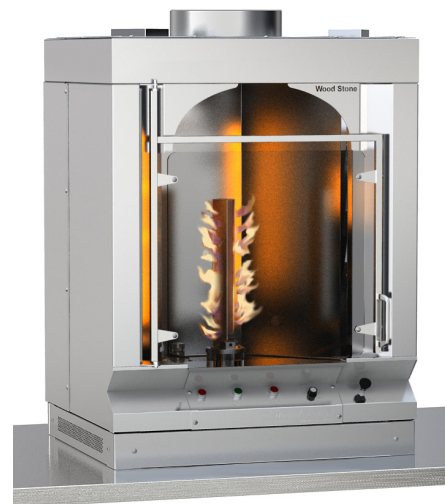

Shown: GVR-10-CT-CE



**INSTALLATION AND OPERATING INSTRUCTIONS FOR THE WOOD STONE
GVR-(6,10)-(DD)-(CT)-CE-(NG, LP)
WHATCOM GAS-FIRED ROTISSERIE**

RETAIN THIS MANUAL FOR FUTURE REFERENCE

Additional copies of this manual at woodstone-corp.com.

READ ALL INSTRUCTIONS BEFORE INSTALLING AND USING THE APPLIANCE

Please read this entire manual before you install the rotisserie. Failure to follow instructions may result in property damage, bodily injury or even death. Contact your local building or fire officials concerning any installation restrictions or the need for inspection of the rotisserie installation in your area.

WARNING: Improper installation, adjustment, alteration, service or maintenance can result in property damage, injury or death. Read the installation, operation and maintenance instructions thoroughly before installing or servicing this equipment.



THIS APPLIANCE IS FOR PROFESSIONAL USE BY QUALIFIED PERSONNEL. THIS APPLIANCE MUST BE INSTALLED BY QUALIFIED PERSONS IN ACCORDANCE WITH THE REGULATIONS IN FORCE. THIS APPLIANCE MUST BE INSTALLED WITH SUFFICIENT VENTILATION TO PREVENT THE OCCURRENCE OF UNACCEPTABLE CONCENTRATIONS OF SUBSTANCES HARMFUL TO HEALTH IN THE ROOM IN WHICH IT IS INSTALLED. THIS APPLIANCE NEEDS AN UNOBSTRUCTED FLOW OF FRESH AIR FOR SATISFACTORY COMBUSTION AND MUST BE INSTALLED IN A SUITABLY VENTILATED ROOM IN ACCORDANCE WITH CURRENT REGULATIONS. THIS APPLIANCE SHOULD BE SERVICED BY QUALIFIED PERSONNEL AT LEAST EVERY 12 MONTHS, OR SOONER IF HEAVY USE IS EXPECTED.

IMPORTANT: Consult your local gas supplier for a statement outlining a procedure to be followed in the event you smell gas. Post the statement in a prominent location.

IMPORTANT: Do not connect this appliance to any gas network containing carbon monoxide or other toxic components.

IMPORTANT: Check appliance data plate to ensure appliance configuration is suitable for gas type and pressure, and suitable for the electrical supply.



This appliance must be installed by a qualified installer. Any conversion to a different gas type must be performed by a qualified technician. Contact your distributor or Wood Stone for information on conversion kits.

WARNING: Do not pack required clearance spaces with insulation or other material.

**IN THE EVENT OF A POWER FAILURE, NO ATTEMPT SHOULD BE MADE TO OPERATE THIS APPLIANCE.
DISCONNECT THE POWER SUPPLY TO THE APPLIANCE BEFORE CLEANING OR SERVICING.**

It is recommended that this rotisserie be installed, maintained and serviced by authorized professionals.

FOR YOUR SAFETY: Do not store or use gasoline or other flammable vapors or liquids in the vicinity of this or any other appliance.

Always keep the area under and around this appliance free and clear of any and all combustible materials.

SAVE THE INSTRUCTIONS

Wood Stone's gas-fired rotisseries have been tested and approved.





Single front door model shown. Two door (front/rear) option available.

Plan view

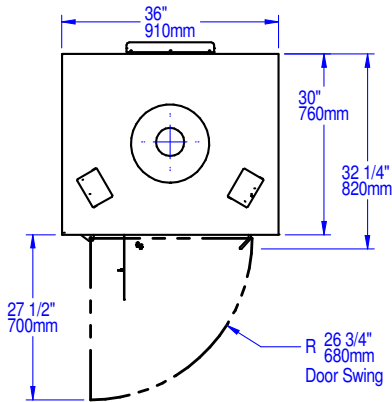

Bottom view

w/ bottom utility connections
on (optional) rear door models

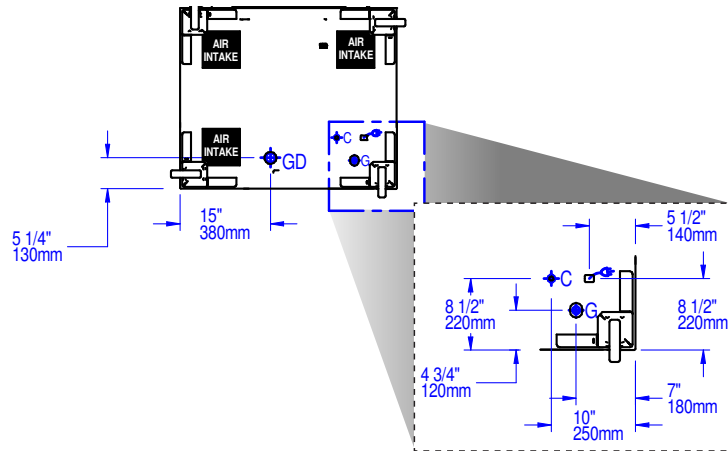

 Air intake: Do not
facade or cover over

**Shipping weight: 340 kg
750 lbs**

Front view

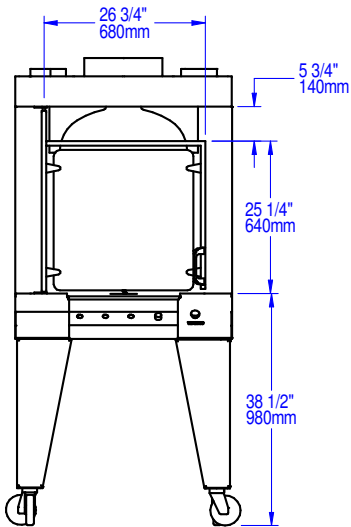

Side view

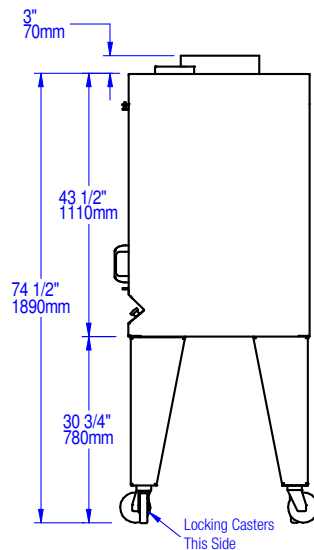

Rear view

w/ standard rear utility connections

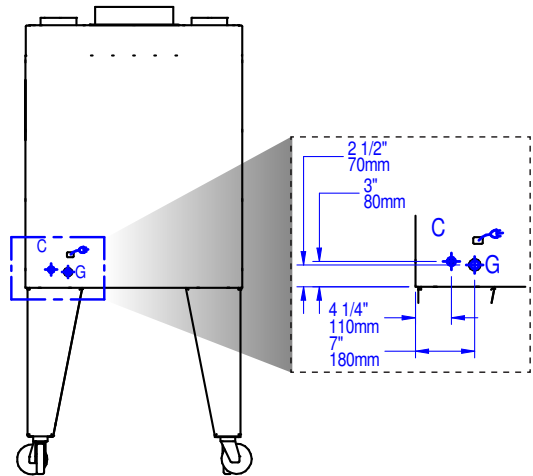

UTILITY SPECIFICATIONS

Gas ⚡ G

19 mm (3/4") FBSPT inlet

See Gas Specifications on page 12 of this manual.

Maximum gas inlet pressure

34 mbar (1/2 psi or 14" W.C.)

Electrical ⚡

230 VAC, 2 A, 50 Hz

Water

Inlet: 8 mm (1/4") ⚡ C

Drain: 40 mm (1-1/2") outlet ⚡ GD

All utility connections made on the rear or bottom of the unit.

Refer to data plate when installing.

Venting

The rotisserie has been approved as a Type A appliance and may be vented using an approved exhaust hood. All exhaust system venting should meet the construction requirements of a grease duct. The rotisserie must be vented in accordance with all relevant local and national codes, and in a manner acceptable to the authority having jurisdiction. See Venting section for further details.



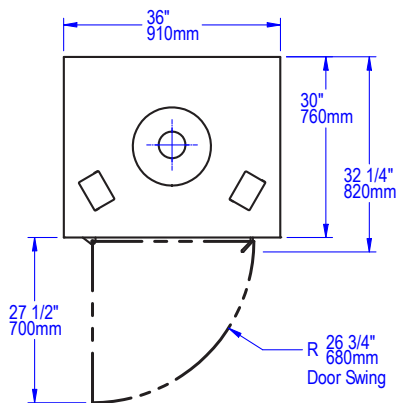

Single front door model shown. Two door (front/rear) option available.

Plan view

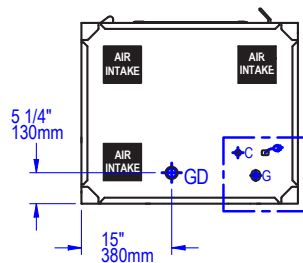

Bottom view



 Air intake: Do not facade or cover over

**Shipping weight: 272 kg
600 lbs.**

Front view

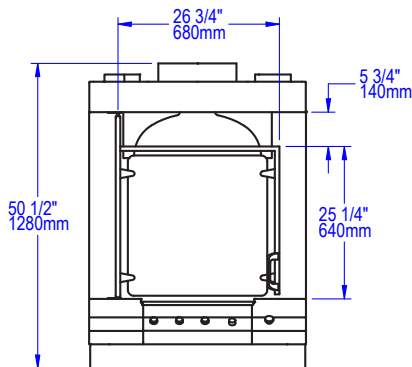

Side view

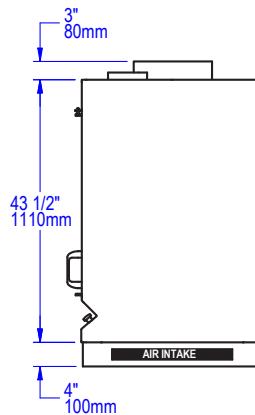

Rear view

w/ standard rear utility connections

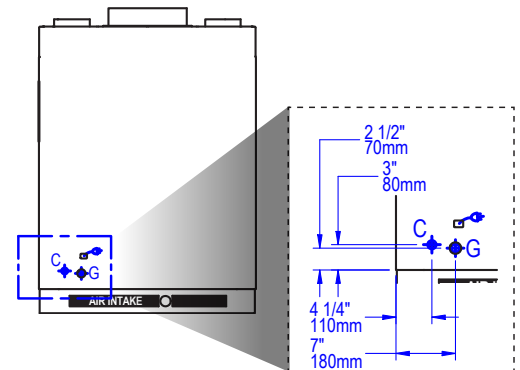

UTILITY SPECIFICATIONS

Gas ⚡G

19 mm (3/4") FBSPT inlet

See Gas Specifications on page 11 of this manual.

Maximum gas inlet pressure
34 mbar (1/2 psi or 14" W.C.)

Electrical ⚡

230 VAC, 2 A, 50 Hz

Water

Inlet: 8 mm (1/4") ⚡C

Drain: 40 mm (1-1/2") BSPT outlet ⚡GD

All utility connections made on the rear or bottom of the unit.

Refer to data plate when installing.

Venting

The rotisserie has been approved as a Type A appliance and may be vented using an approved exhaust hood. All exhaust system venting should meet the construction requirements of a grease duct. The rotisserie must be vented in accordance with all relevant local and national codes, and in a manner acceptable to the authority having jurisdiction. See Venting section for further details.



CLEARANCES

FRONT

- Allow **914mm (3')** to allow for door swing and user access.

SIDES

- Minimum clearance from sides of rotisserie to **combustible** construction is **152mm (6")**.
- Minimum clearance from sides of rotisserie to **non-combustible** construction is **0"**.

BACK

- Minimum clearance from back of rotisserie to **combustible** construction is **152mm (6")**.
- Minimum clearance from back of rotisserie to **non-combustible construction is 0"**.

FLOOR

- Installation on **non-combustible** floors only.

OPTIONAL REAR DOOR MODELS - BACK

(model number includes "-DD")

- Minimum clearance from back of rotisserie to **combustible** construction is **304mm (12")**.
- Minimum clearance from back of rotisserie to **non-combustible construction is 0"**.
- However, allow **914mm (3')** at rear to allow for door swing and user access.

SERVICE ACCESS
Countertop models must allow access all the way around and above unit as shown below.
Caster units must be able to roll completely free from obstructions to allow access as shown below.

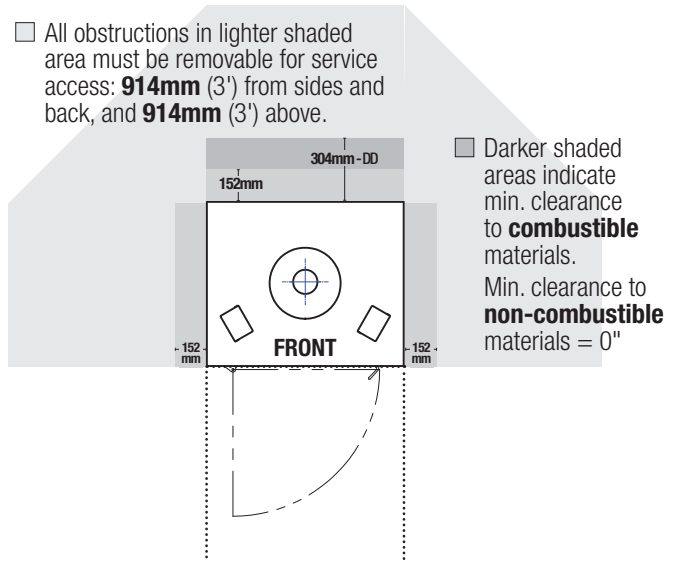

⋮ Leave area within dotted lines open **914mm (3')** to allow door swing and user access.

With optional Double Door models, the same access **914mm (3')** is also required.

This appliance is not intended to be fixed to an installation wall.

WARNING: Do not pack required clearance spaces with insulation or other material.



CASTER EQUIPPED ROTISSERIES

Utility hookups should be made in such a way as to allow mobility of the rotisserie for service and maintenance purposes.

ATTENTION INSTALLER: EQUIPMENT RESTRAINT MUST BE PROVIDED

Adequate means must be provided to limit the movement of the appliance without depending on the connector and the quick disconnect device or its associated piping to limit the appliance movement. Use the hole located on the left rear leg of the rotisserie cabinet to attach the restraining device(s) (see photo to right).

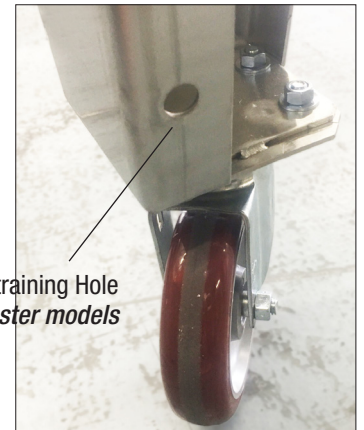

Restraining Hole
Caster models

COUNTERTOP MODELS

TO SECURE THE ROTISSERIE TO THE COUNTER

- Remove the curb walls at the base of the unit to access the legs.
- Fasten the unit to the countertop using the 9.5 mm (3/8") holes in the bottom of each leg.
- Replace curb walls.

NOTE: ALL SIDES AND TOP OF UNIT MUST BE READILY ACCESSIBLE FOR SERVICE.

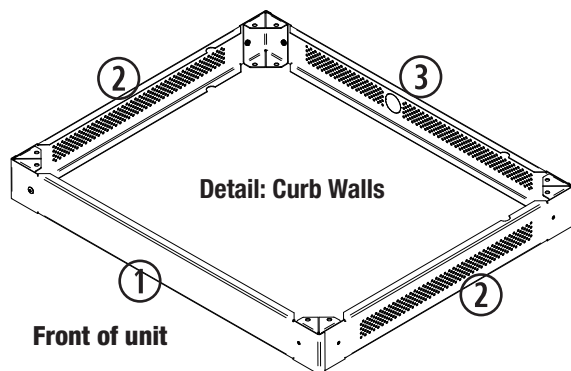

Corner detail
Countertop
models

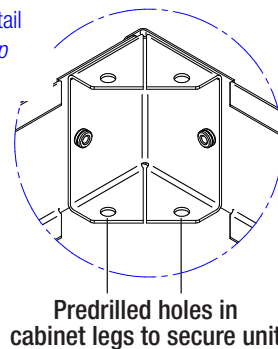



GAS: See GAS SPECIFICATIONS section on page 12.

ELECTRICAL: 230 VAC 2 A, 50 Hz

Electrical Grounding: Plug only into an earthed (grounded) 3-prong receptacle.

Provide Disconnect Device: This appliance must be provided with an all-pole type disconnect device in the incoming power supply so that the appliance can be completely isolated from the power supply.

WATER: Cold water supply to the 8 mm (1/4") water inlet (female) at the back of the rotisserie. Connect to a water supply with a pressure of 207-620 Kpa (30–90 psi). Connect to a potable water supply in accordance with national regulations.

DRAIN: A 40 mm (1-1/2") drain outlet tube at the bottom of the rotisserie is provided. This outlet must be connected to an indirect waste pipe and discharge by means of an air gap in accordance with all applicable plumbing codes.

The indirect waste pipe must discharge by means of an air gap into a drain system connected to a grease trap.

This appliance must be installed with an approved backflow prevention device (supplied by others), in accordance with local and national plumbing codes.

On countertop models, the indirect waste pipe may be installed down through the countertop. Alternatively, using a 40 mm (1-1/2") drain elbow (available at any hardware store) in place of the provided straight fitting will allow routing out the side or back of the unit. If routed using the elbow, it will be necessary for the installer to cut the appropriate hole in the side or back of the rotisserie.

UTILITY CONNECTION LOCATIONS

Rear view

Standard utility placement

Bottom view

Optional utility placement

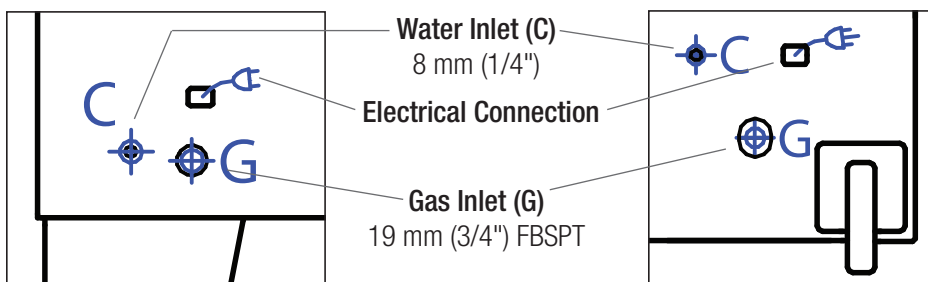



Wood Stone rotisseries should be vented in accordance with pertinent national, regional and local codes concerning such appliances; check venting plans with the authority having jurisdiction before proceeding with installation.

The above statement taking precedence, Wood Stone Corporation recommends the following options:

- This Wood Stone Rotisserie must be vented as a Type A appliance (with no flue connection), designed to be installed under an exhaust hood (canopy). The hood must be connected to a grease-rated duct system. The venting system must be designed and installed in accordance with all relevant codes pertaining to grease and smoke producing commercial cooking appliances. Check with your local code official.

Airflow should be adjusted according to the requirements specified by the hood manufacturer and/or local codes.

WOOD STONE RECOMMENDS THAT THE OPERATOR REFER TO THE EXHAUST HOOD MANUFACTURERS FOR INSPECTION, MAINTENANCE AND CLEANING. THE HOOD AND VENTILATION SYSTEM SERVING THIS APPLIANCE MUST BE INSPECTED AND CLEANED ON A REGULAR BASIS. WOOD STONE RECOMMENDS CLEANING AND INSPECTION OF THE HOOD AND VENTILATION SYSTEM BY QUALIFIED PERSONNEL EVERY 3 MONTHS.

INTERLOCK SYSTEM

There may be requirements for interlocking the rotisserie or its gas supply with the ventilation system. Check with your local code official.



NATURAL GAS (NG)

Gas Supply and Pressure

WS-GVR-(6,10)-(CT)-(DD)-CE-NG

EN 437 Gas Group		I _{2H}	I _{2ELL}	I _{2EK}
Declared Input (kW)		33.7	33.7	28
Inlet Pressure (mbar)		20	20	25
Declared Pressure at Gas Valve Outlet (mbar)	IR Burners SV-2, 3	12.5	12.5	12.5
	Radiant Burner SV-1	8.7	8.7	8.7

SCOPE OF APPROVALS

G20(G25.3) @ 25 mbar - I_{2EK} - NL, DE, PL

G20 @ 20 mbar - I_{2H} - AT, DK, ES, FI, IE, IT, PT, GB, SE, CH, GR, EE, LV, SI, HR, SK, CZ

G25 @ 25 mbar - I_{2L} - HU

G20 @ 25 mbar - I_{2HS} - HU

G20 @ 20 mbar - I_{2ELL} - DE

PROPANE (LP)

Gas Supply and Pressure

WS-GVR-(6,10)-(CT)-(DD)-CE-LP

EN 437 Gas Group		I _{3B/P}	I _{3B/P}	I _{3P}
Declared Input (kW)		40.5	40.5	38.0
Inlet Pressure (mbar)		30/37*	50*	30/37/50*
Declared Pressure at Gas Valve Outlet (mbar)	IR Burners SV-2, 3	25	25	25
	Radiant Burner SV-1	22.5	22.5	22.5

SCOPE OF APPROVALS

G31 @ 37 mbar* - I_{3P(37)} - CH, DE, ES, FI, GB, GR, HR, IE, LU, NL, PL, SI, SK, TR

G31 @ 50 mbar* - I_{3P(50)} - CY, CZ, MT, SK

G30 @ 30 mbar - I_{3B/P(30)} - BG, CY, CZ, DK, EE, FI, GR, HR, LV, LT, LU, MT, NL, NO, SK, SI, SE, TR

G30 @ 50 mbar* - I_{3B/P(50)} - AT, DE, HU, SK, CH

Connect to an approved 3/4" flexible catering supply hose not to exceed 2M in length. Gas connection is made at the rear of the appliance. Use an approved restraining device in accordance with national and local codes. The gas supply hose must be inspected regularly and replaced as necessary.

*** Propane (LP): Maximum inlet gas pressure to the rotisserie, after the external regulator, must not exceed 34 mbar (14" W.C. or 1/2 psi).**

**GAS CONNECTION**

The gas control valves that operate the burners are located behind the rear service panels. SV-1 controls the Flame Post Burner. The manifold pressure is checked at the outlet port on the SV-1 gas valve.

SV-2 and SV-3 control the left and right Infrared (IR) Burners. The manifold pressures are checked at the outlet port on the individual gas valves.

The burner manifold pressures have been adjusted and tested at the factory. A variety of factors can influence these pressures, so be sure to test the individual burner manifold pressures and adjust the valves as necessary to achieve the required pressures.

Wood Stone rotisseries are equipped with a 19mm (3/4") FBSPT gas connection (female thread). Have a licensed gas installer provide the hook-up and test all fittings and pipe connections for leaks. Use approved gas leak detectors (soap solutions or equivalent) over and around the fittings and pipe connections to check for leaks. **DO NOT USE A FLAME TO TEST FOR LEAKS!**

All gas piping up to the rotisserie must have a minimum inside diameter of 19mm (3/4"), including all fittings and shut off valves, which should be of the full flow type.

Wood Stone recommends that the rotisserie be equipped with a manual, individual shutoff valve, located between the rotisserie and the main gas supply, and that this shutoff valve (supplied by others) be left readily accessible. Wood Stone also recommends that inspection and maintenance of the burners and gas piping connections of this appliance be performed at regularly scheduled intervals and only by professional gas appliance service agencies.

Natural Gas (NG): Maximum inlet gas pressure must not exceed 34 mbar (14" W.C. or 1/2 psi)

Propane (LP): Maximum inlet gas pressure to the rotisserie, after the external regulator (if used), must not exceed 34 mbar (14" W.C. or 1/2 psi)

GAS INLET PRESSURE

For rotisseries running on natural gas, an inlet pressure of 17.5–25 mbar (7 to 10" W.C.) is recommended to ensure optimum rotisserie performance. Incoming gas pressure below this range will affect rotisserie performance, the lower the pressure the greater the negative impact. If the gas supply pressure is greater than 34 mbar (14" W.C. or 1/2 psi), an external regulator, supplied by others, is REQUIRED to lower the gas pressure to the acceptable range. Issues caused by low or high gas pressure are installation issues, and will not be covered under the Warranty.

For rotisseries running on LP, the recommended inlet pressure to ensure optimum rotisserie performance is 25–30 mbar (10 to 12" W.C.) Incoming gas pressure below this range will affect rotisserie performance, the lower the pressure the greater the negative impact. If the gas supply pressure is greater than 34 mbar (14" W.C. or 1/2 psi), an external regulator, supplied by others, is REQUIRED to lower the gas pressure to the acceptable range. Issues caused by low or high gas pressure are installation issues, and will not be covered under the Warranty.

For all installations, follow best practices for proper gas line pipe sizing for the line serving the rotisserie. To ensure proper operation, all gas piping and fittings leading up to the rotisserie should have an inside diameter equal to or greater than that of the rotisserie gas connection. Also make sure that a readily accessible shut off valve (supplied by others) is installed near the rotisserie, and in accordance with all applicable codes. Shut off valves must be of the full-flow type, and not introduce any restriction into the gas line.

Use a properly sized flexible pipe and quick disconnect device approved for this application. When using a flexible connector make sure that its design does not present any reduction in pipe diameter or other restriction. Rotisserie issues caused by improper pipe sizing, improper shut off valves, restrictive connectors, or any other deficiency in the gas supply design or installation will not be covered under the rotisserie warranty.

Countertop models may be hard-piped if necessary.



**REMOVE REAR CORNER
PANELS TO ACCESS GAS
VALVES AND ELECTRICAL
COMPONENTS.**

**Rear Corner Panels
must remain removable
for service**

Diagram shown with
optional rear door

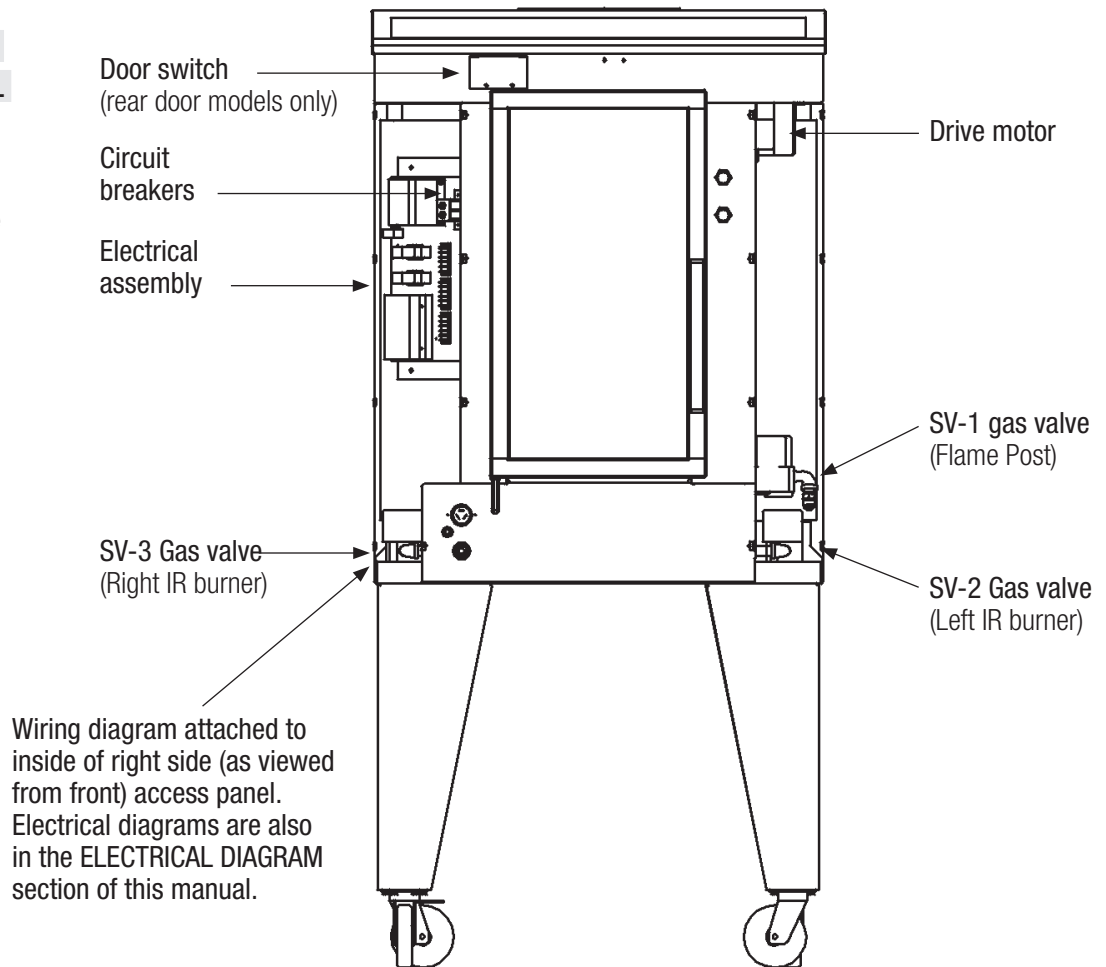



FRONT CONTROLS



START - STOP - JOG - IR - WATER

NOTE: Pressing the **RED** stop button at any time will stop drum rotation and turn off the burners.

REAR CONTROLS (WITH OPTIONAL REAR DOOR)

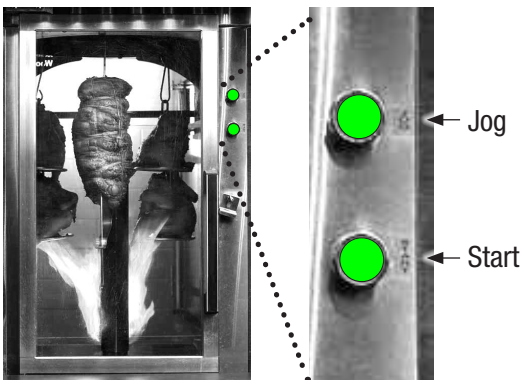

NOTE: Opening the rear door (if equipped) will stop drum rotation and turn off the burners.

Additional Controls located on the back, to upper right of the doors, on models with optional rear door.



1. Make sure all utilities are connected, the unit is installed under a Type 1 Listed Exhaust Hood and the Fan for the Exhaust Hood is turned on.



Drain
Stand
Pipe

2. Install the Drain Stand Pipe into the rotisserie drain.



Flame
Post
Guard
Flame
Post

3. Make sure the Flame Post Guard is installed over the Flame Post Burner.



4. Install IR Burner Reflector Plates at the base of the left and right IR Burners.

5. Turn the Water Knob on the front panel to fill the water bath until the water begins to drain out the holes in the Drain Stand Pipe. Then reduce the flow to a trickle while the unit is in operation. The water bath must be filled to prevent heat damage to the rotisserie cabinet. Plus the water simplifies cleaning. The warmed flowing water carries the grease easily and safely out of the cabinet and down the drain (which must be connected to a grease trap).
6. With the rotisserie **OFF**, you may load the unit from the back door (if equipped), or from the front. **TO AVOID BODILY INJURY, NEVER REACH INTO THE ROTISSERIE WHEN IT IS RUNNING.** Load the spits and hang them onto the drum at the top of the rotisserie interior. The total combined load of all the spits should not exceed 45kg (100 lbs). Hang the spits so that the load is distributed evenly. Use the **JOG** button (green button near the center of the front panel) as necessary to rotate the drum when hanging the spits. On units equipped with a rear door, there is also a **JOG** button located on the back, next to the door. The drum will turn only while the button is depressed—release the button to stop the rotation. The burners do not fire when using the **JOG** function.
7. Press the **START** button (green button on the left) to fire the center Flame Post and start rotation automatically. The infrared burners will light and cycle according to the **IR TIMER KNOB** setting from 0–100%. The Timer is calibrated as a percentage of 10 minutes, i.e. 60% = 6 minutes ON followed by 4 minutes OFF. Turning the **IR TIMER KNOB** clockwise increases the percentage of time that the burners cycle remains on. On the units equipped with a rear door, there are also a **START** and **JOG** buttons located on the upper back, next to the right of the door. **Always wait 5 minutes before relighting the burners.**
8. The rotisserie comes standard with a variety of spits and accessories including bird bells, small item skewers and rib/meat hooks.

Ten Spit Models: There are ten (10) spit locations (stations). Up to three (3) bird bells may be hung from each station, but birds cannot be cooked at adjacent stations due to space limitations. This gives the rotisserie a capacity of (15) birds.

Six Spit Models: There are six (6) spit locations (stations). Up to three (3) bird bells may be hung from each station. This gives the rotisserie a capacity of (18) birds.

WS rotisseries are designed and tested to meet the requirements concerning the hygiene aspects of large kitchen appliances using gaseous fuels, so as to eliminate or minimize the risk of contagion, infection, illness or injury arising from the consumption of contaminated food.



ROUTINE CLEANING OF THE ROTISSERIE CABINET INTERIOR

See next page for illustrated version of these instructions.

- Pull out the drain stand pipe and allow the water to flow down the drain.
- Remove the two Infrared (IR) Burner Reflectors at the base of each side IR Burner for cleaning.
- Lift the center Flame Post Guard straight up off the Flame Post.
 - Scrape, if necessary, then wash by hand or in dishwasher.
- With a warm damp cloth, wipe up any grease remaining in the cabinet.
- Then use a clean dry cloth to dry and polish the surface.

IMPORTANT: Do not to get liquid onto the center Flame Post Jets, the side Infrared Burners or the Igniters.

- Be careful not to wipe or spray onto the Infrared Burners or Jets.
- Do not touch or attempt to clean the Igniters located near the top of each burner.
- The Flame Post Guard must be lifted off of the center Flame Post for cleaning. **NOTE:** The Flame Post should never be wiped down or cleaned in place as the jets will clog. The correct way is to always lift the Flame Post Guard off the center post and manually wash while it is off the center post. When replacing Flame Post Guard, be careful to line up the holes correctly with the Jets.

CLEANING THE ROTISSERIE CABINET EXTERIOR

- All exposed surfaces of the rotisserie should be wiped clean as necessary (or daily) using an approved mild cleaning solution.
- Be careful not to get excess liquid into any of the switches or controls.
- Stubborn residues may be removed using a non-metallic scouring pad.
- When scouring stainless steel, scrub with the grain to avoid scratching the finish.

CLEANING THE GLASS

Use hot soapy water to remove most of the grease splatters, then an appropriate glass cleaner to clean the glass. **Do not** use any abrasive cleaners or pads on the glass doors.

CLEANING THE ACCESSORIES

All rotisserie attachments (spits, forks, etc.) should be cleaned between uses using an approved mild detergent, hot water and sanitizing agent. Alternatively, these items can be cleaned in a dishwasher.

PERIODIC CLEANING UNDER COUNTERTOP MODELS

The 4" Curb Walls at the base of the unit can be removed in the order indicated below: front, sides and then rear.

Each of the four walls is secured by two screws.

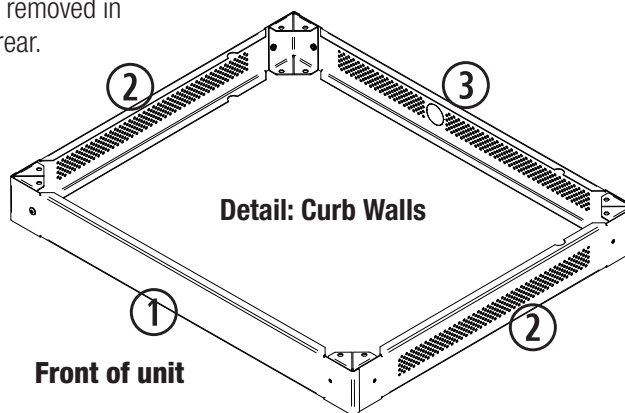



ROUTINE CLEANING PROCEDURE



Lift out Drain Stand Pipe.



Lift Flame Post Guard completely off
Flame Post Burner



Lift up and pull out the two
IR Burner Reflectors.



If serious buildup, place parts on sheet
pan, outside of rotisserie.



Scrape off debris with putty knife.

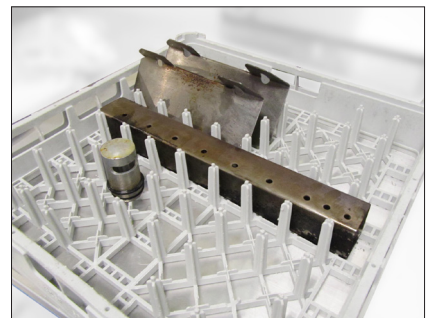

Wash parts in dish machine or manually
in sink using aproved dishwashing
methods (wash, rinse, sanitize).



DO NOT wipe Flame Post Jets.



DO NOT wipe IR Burners.



DO NOT wipe Igniters.

Scrape build-up from
Flame Post base
with putty knife.

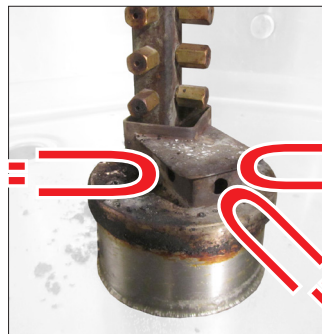

DO NOT allow debris into
holes at Flame Post base.



ROUTINE PREVENTATIVE MAINTENANCE

- Clean the rotisserie daily as described above.
- Periodically check control switches and glass mounting hardware for tightness.
- Retighten any loose switch bezels or mounting hardware as necessary.
- Periodically inspect the condition of the power supply cord.
- Refer to the exhaust hood manufacturer’s recommendations for inspection, maintenance and cleaning.

TROUBLESHOOTING AND REPAIR

IF YOU EXPERIENCE A PROBLEM WITH THE ROTISSERIE...

- Make sure that the power cord is securely plugged into the rotisserie and a functioning electrical outlet.
- Make sure the gas supply is connected to the rotisserie and turned on.
- Make sure the hood system is turned on.

If the rotisserie is still not functioning properly please call your local distributor.

COMMON REPAIR PARTS

IGNITION MODULE	70ROW-0049
GAS CONTROL VALVE (SPECIFY NG OR LP)	70CE-0010
IR IGNITER	70ROC-0006
FLAME POST IGNITER	70ROW-0017
50” IGNITER WIRE	70ROC-0007
DRIVE BELT	70ROW-0053
PLANETARY V-BELT	70ROW-0052
DRAIN PLUG ASSEMBLY	50ROW-0021
SWITCH (WORKS FOR START, STOP OR JOG)	7000-1821
PERCENT TIMER CONTROL	70ROW-0024
IR POTENTIOMETER	002-60ROW-1

Contact your distributor or wood stone to order parts.



The **GVR Smoker Tray** is an optional stainless steel, dual compartment tray, designed to create smoke in the Whatcom GVR. It sits on the floor of the gas-fired rotisserie, on either side of the Flame Post. The smoke tray acts as a flavor enhancer as well as imparting the distinctive aroma of a wood-fire.

The GVR Smoker Tray is designed to use a maximum of about a half pound of wood chips to create smoke. Properly managed, it will provide smoke for approximately 45 minutes to 1 hour before needing wood replenishment.

CAUTION: Keep the Smoker Tray covers on except when refilling.

CLEANING

Remove the left and right side tray covers and scrape off the burnt on grease. **CAUTION:** Always consider the Smoker Tray and its contents to be very hot. Use insulated gloves.

The covers can be cleaned with oven cleaner, following the manufacturer's usage recommendation.

EMPTYING THE SMOKER TRAY

- Remove the left and right tray covers. **CAUTION:** Always consider the Smoker Tray and its contents to be very hot. Use insulated gloves.
- Slide the base of the unit out of the rotisserie.
- Place ashes into a metal container with a tight fitting lid.

DISPOSE OF ASH PER THE FOLLOWING:

1. Place ashes into a metal container with a tight fitting lid.
2. Place the closed container of ashes on a non-combustible floor or on the ground.
3. Place the closed container of ashes well away from all combustible materials, pending final disposal.
4. Retain the ashes in the closed container until all the cinders have thoroughly cooled. Ashes can then be disposed of safely.

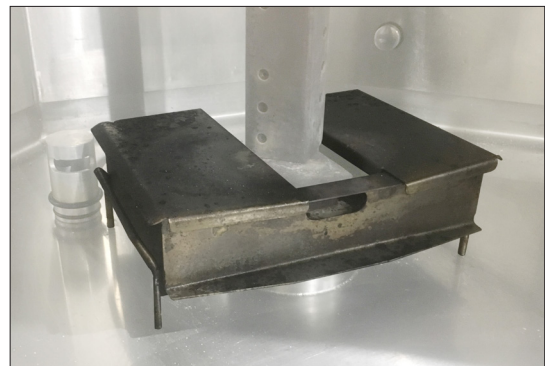

Wood Stone's stainless steel Particle Shovel and Double Compartment Ash Dolly disposal system offer a safe and convenient way to dispose of ash. Specification sheets may be viewed on the Wood Stone website under Tools & Accessories.





These diagrams can also be found affixed to the inside of the drive-side service panel of the rotisserie.

Whatcom Vertical Gas Rotisserie - CE

Electrical Diagram

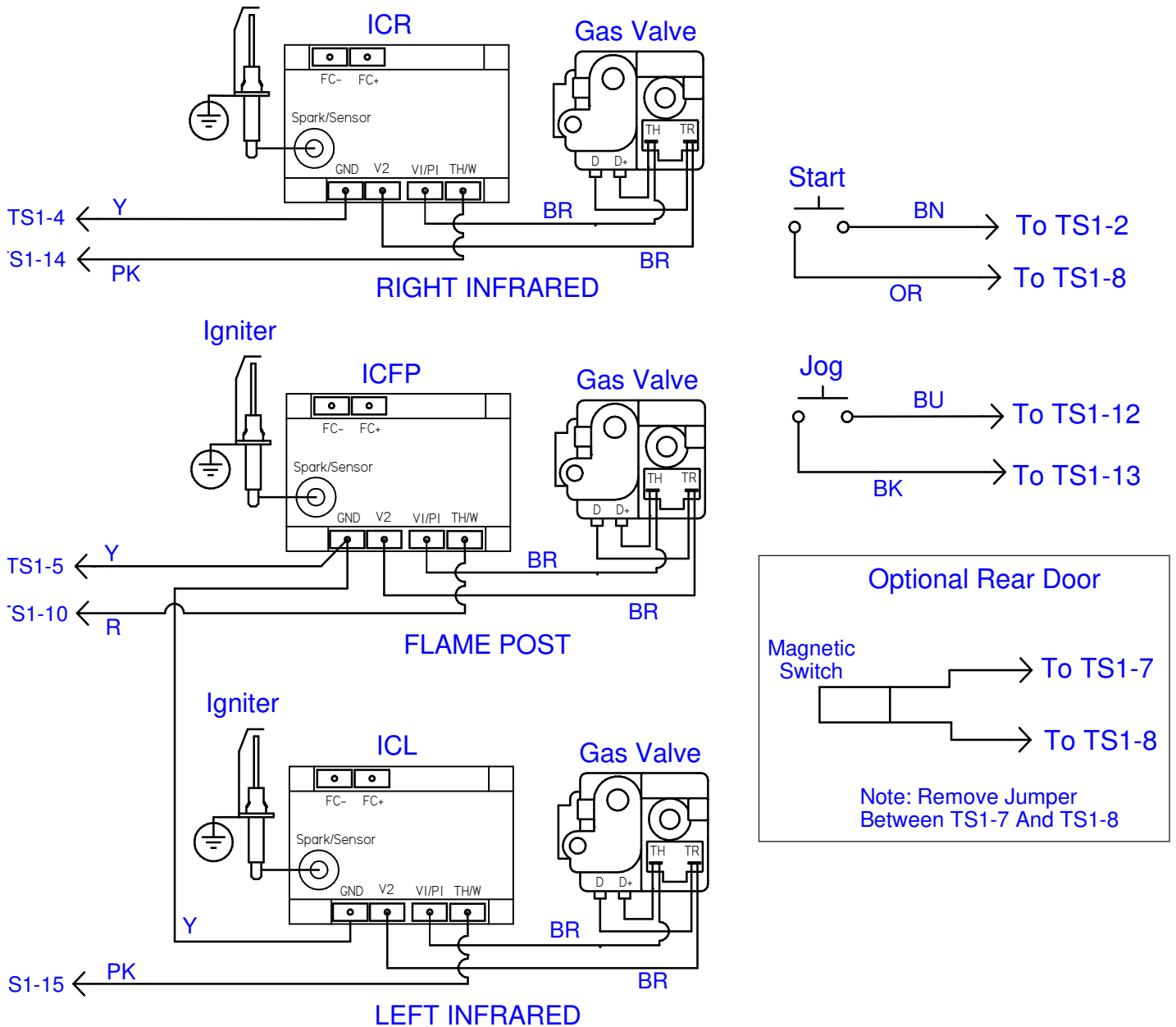



These diagrams can also be found affixed to the inside of the drive-side service panel of the rotisserie.

Whatcom Vertical Gas Rotisserie - CE

Electrical Diagram

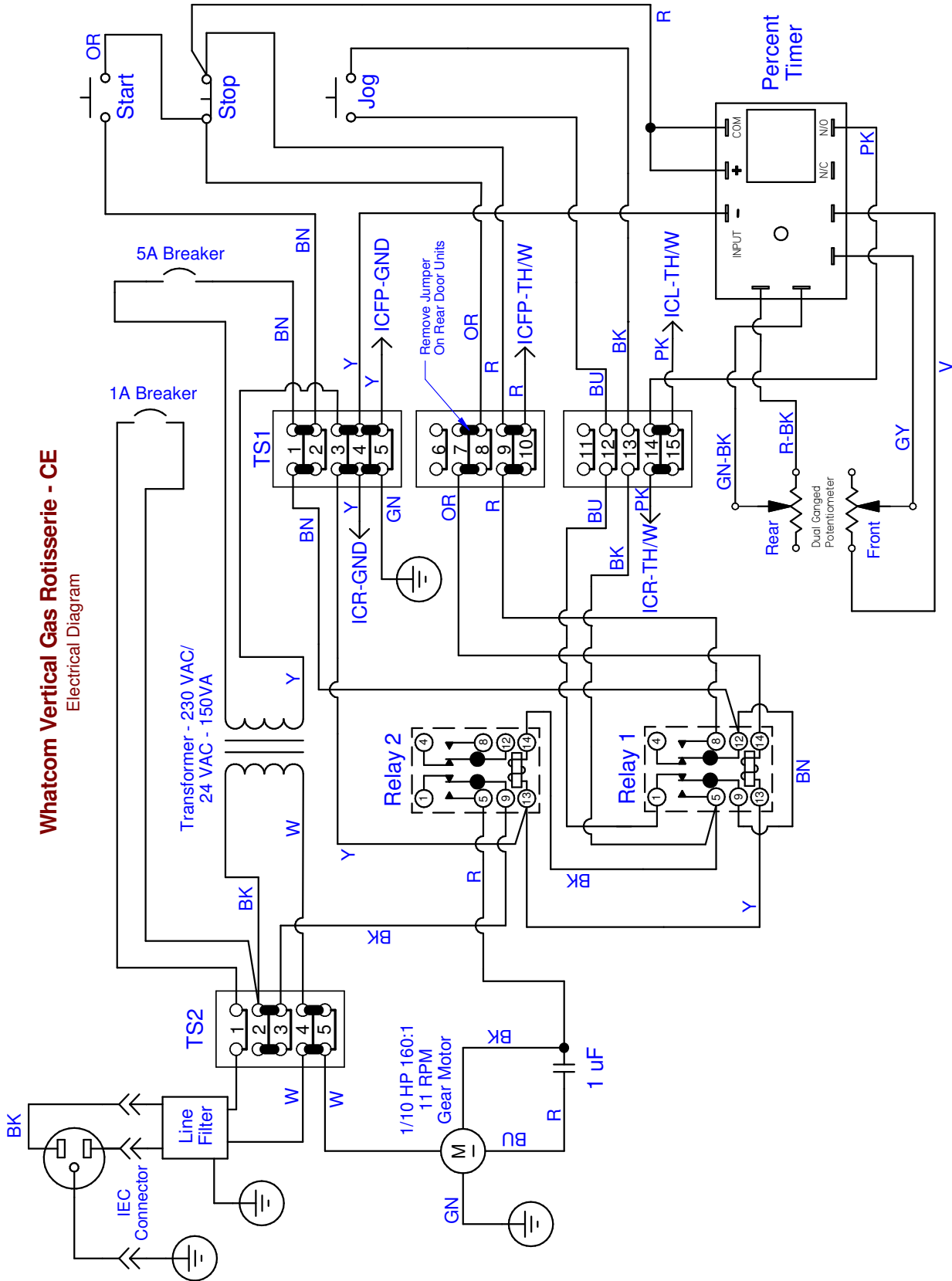

DIAG #: WD223 Rev. 1
SHEET: 2 of 2
DATE: 1/30/2018

Wood Stone
Bellingham, WA +1(360)650-1111 www.woodstone-corp.com



WOOD STONE WARRANTS ITS EQUIPMENT TO THE ORIGINAL PURCHASER AGAINST DEFECTS IN MATERIAL OR MANUFACTURE FOR A PERIOD OF ONE YEAR FROM THE ORIGINAL DATE OF PURCHASE, SUBJECT TO THE FOLLOWING EXCLUSIONS AND LIMITATIONS. CONTACT YOUR LOCAL DISTRIBUTOR FOR WARRANTY SERVICE

EXCLUSIONS

The warranties provided by Wood Stone do not apply in the following instances:

1. In the event that the equipment is improperly installed. Proper installation is the responsibility of the installer; proper installation procedures are prescribed by the Wood Stone Installation and Operation Manual.
2. In the event the equipment is improperly or inadequately maintained. Proper maintenance is the responsibility of the user; proper maintenance procedures are prescribed in the Wood Stone Installation and Operation Manual. Burner problems resulting from debris or ash in the burner well will not be covered by the warranty. Call with questions regarding maintenance frequency.
3. In the event that the failure or malfunction of the appliance or any part thereof is caused by abnormal or improper use or is otherwise not attributable to defect in material or manufacture.
4. In the event that the appliance, by whatever cause, has been materially altered from the condition in which it left the factory.
5. In the event that the rating plate has been removed, altered or obliterated.
6. On parts that would be normally worn or replaced under normal conditions.
7. Normal cracking due to expansion and contraction stress relief in the ceramic firebox.
8. In wood-fired equipment configurations, in the event that pressed log products of any type have been burned in the equipment.
9. In coal-fired oven configurations, in the event any type of coal other than anthracite coal fuel has been used.
10. Damage resulting from the use of chemical cleaning products in the oven, as well as any damage from liquids or chemicals, including water, being poured or sprayed into the oven.

If any oral statements have been made regarding this appliance, such statements do not constitute warranties and are not part of the contract of sale. This Limited Warranty constitutes the complete, final and exclusive statement with regard to warranties.

THIS LIMITED WARRANTY IS EXCLUSIVE AND IN LIEU OF ALL OTHER WARRANTIES WHETHER WRITTEN, ORAL OR IMPLIED, INCLUDING, BUT NOT LIMITED TO, ANY WARRANTY OF MERCHANTABILITY OR FITNESS FOR PARTICULAR PURPOSE OR WARRANTY AGAINST LATENT DEFECTS

LIMITATIONS OF LIABILITY

In the event of warranty claim or otherwise, the sole obligation of Wood Stone shall be the repair and/or replacement, at the option of Wood Stone, of the appliance or component or part thereof. Such repair or replacement shall be at the expense of Wood Stone with the exception of travel over 100 miles or two hours, overtime, and holiday charges which shall be at the expense of the purchaser. Any repair or replacement under this warranty does not constitute an extension of the original warranty for any period of the appliance or for any component or part thereof. Parts to be replaced under this warranty will be repaired or replaced at the option of Wood Stone with new or functionally operative parts. The liability of Wood Stone on any claim of any kind, including claims based on warranty, expressed or implied, contract, negligence, strict liability or any other theories shall be solely and exclusively the repair or replacement of the product as stated herein, and such liability shall not include, and purchaser specifically renounces any rights to recover, special, incidental, consequential or other damages of any kind whatsoever, including, but not limited to, injuries to persons or damage to property, loss of profits or anticipated profits, or loss of use of the product.

TO SECURE WARRANTY SERVICE:

Contact your local distributor.

WOOD STONE

WOOD STONE CORPORATION

1801 W. Bakerview Rd.

Tel +1.360.650.1111

Bellingham, WA 98226 USA

Fax +1.360.650.1166

www.woodstone-corp.com

An ongoing program of product improvement may require us to change specifications without notice.