

Installation and Operation Manual



FIRE DECK SERIES

Stone Hearth Oven

Gas-Fired, Gas/Wood Combination Models

FIRE DECK 6045 WS-FD-6045

WOOD  STONE

WOOD STONE CORPORATION

1801 W. Bakerview Rd.
Bellingham, WA 98226 USA

Toll Free 800.988.8103

Tel 360.650.1111

Fax 360.650.1166



TABLE OF CONTENTS

Fire Deck 6045 3

Cautions & Warnings 4

FD-6045 Specifications 6

Unloading & Moving the Oven 7

Optional Temp Caster Install 8

Placing & Installation 9

Installation Clearances10

Facade Guidelines11

Facade Requirements12

Venting13

Hood Specifications14

Gas Specifications15

Electrical Specifications17

Controller18

Initial Start-Up19

Daily Oven Operation20

Flame Height Control21

Wood Burning22

Daily Maintenance & Thermal Cleaning . .23

Troubleshooting Guide24

Fuelwood Facts25

Decorative Flame Burner26

Electrical Diagrams27

Interlock Diagram30

Limited Warranty31



**INSTALLATION AND OPERATION MANUAL FOR THE
WOOD STONE FIRE DECK**

STONE HEARTH COOKING EQUIPMENT

WS-FD-6045-(RFG)-(L, R, LR)-(IR)-(W)-(NG, LP, HLP) MODELS

GAS AND GAS/WOOD MODELS

ADDITIONAL COPIES AVAILABLE UPON REQUEST



Shown: FD-6045-RFG-R-IR

**WOOD STONE WS-FD-6045 FIRE DECK INSTALLATION AND OPERATING INSTRUCTIONS****RETAIN THIS MANUAL FOR FUTURE REFERENCE**

Additional copies of this manual at woodstone-corp.com.

For prompt responses to service/maintenance questions, call us at @ 1-800-988-8103.

READ ALL INSTRUCTIONS BEFORE INSTALLING AND USING THIS APPLIANCE

Please read this entire manual before you install the oven. Failure to follow instructions may result in property damage, bodily injury or even death. Contact your local building or fire officials about restrictions and installation inspection in your area.

IMPORTANT: Consult your local gas supplier for a statement outlining a procedure to be followed in the event you smell gas. Post the statement in a prominent location.

FOR YOUR SAFETY: Do not store or use gasoline or other flammable vapors or liquids in the vicinity of this or any other appliance.

ESURE DE SÉCURITÉ: Ne pas entreposer ni utiliser de'essence ni autres vapeurs ou liquides inflammables à proximité de cet appareil ou de tout autre appareil.

Always keep the area under and around this appliance free and clear of any and all combustible materials.

WARNING: Improper installation, adjustment, alteration, service or maintenance can cause property damage, injury or death. Read the installation, operation and maintenance instructions thoroughly before installing or servicing this equipment.

AVERTISSEMENT: L'installation, le réglage, la modification, la réparation ou l'entretien incorrect de cet appareil peut causer des dommages matériels, des blessures ou la mort. Lire attentivement les instructions d'installation, de fonctionnement et d'entretien avant de procéder à son installation ou entretien.

CAUTION: Disconnect power to the oven before servicing or cleaning.

No attempt should be made to operate this appliance during a power failure.



A MAJOR CAUSE OF OVEN RELATED FIRES IS A FAILURE TO MAINTAIN REQUIRED CLEARANCES TO COMBUSTIBLE MATERIAL. IT IS OF UTMOST IMPORTANCE THAT THIS OVEN BE INSTALLED ONLY IN ACCORDANCE WITH THESE INSTRUCTIONS.

It is recommended that this oven be installed, maintained and serviced by authorized professionals.

This product must be installed by a licensed plumber or gas fitter when installed within the Commonwealth of Massachusetts.

SAVE THE INSTRUCTIONS

Wood Stone ovens have been tested and approved by Intertek Testing Services and conform to ANSI Z83.11, UL 2162, UL 737 and CGA 2.17; are certified to CSA 1.8, ULC/ORD 2162 and ULC S627; and to NSF/ANSI 4.



Intertek
ANSI Z83.11
CSA 1.8



Intertek
ANSI/NSF 4



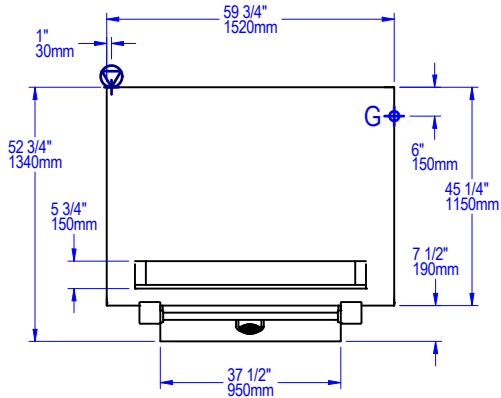

Plan view



NOTES

This oven is available in a left or right side burner configuration. Gas connections will be on the same side of the oven as the radiant flame. Electrical connections are always on the left. Shown: Right side burner configuration.

NOTE: Using the temporary optional casters will add 3" to the height of the oven, resulting in a 77-1/2" total. However, the 3-3/4" vent shield on top can be removed temporarily if necessary.

-  Air intake: Do not facade or cover over
-  Must be left removable for service

**Unit Shipping Weight:
3,200 lbs.**

Front view

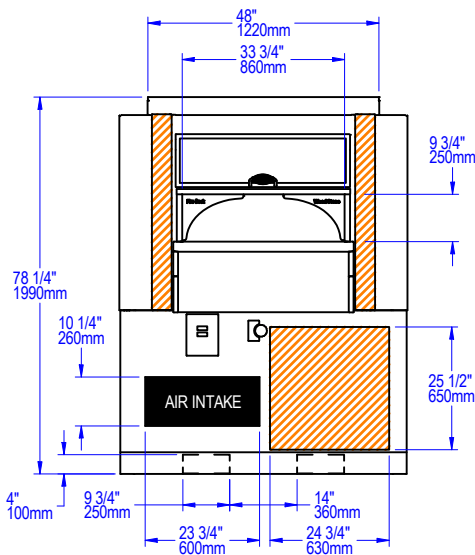

Side view

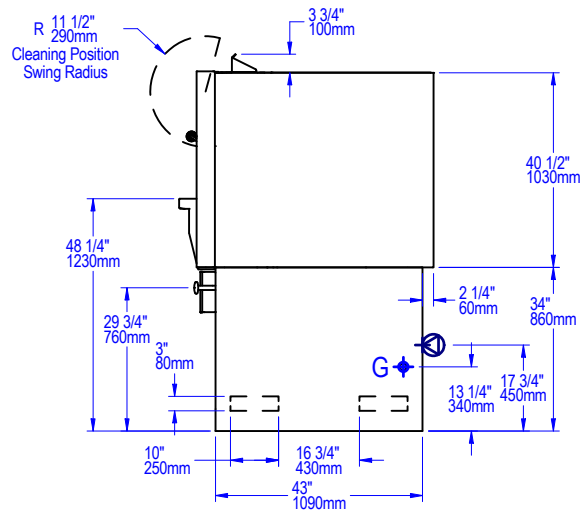

UTILITIES SPECIFICATIONS

Gas

3/4 inch FNPT gas inlet
160,000 BTU/hr Natural Gas (NG)

OR

160,000 BTU/hr Propane (LP)
*Optional Decorative Flame adds
15,000 BTU/hr to total rated input*

*Maximum gas inlet pressure:
1/2 psi (14 inches W.C.)*

Electrical

120 VAC, 1.1 A, 50/60 Hz
240 VAC, 1 A, 60 Hz (optional)

Electrical connection always on the left side of the oven. Gas connection on same side as Radiant Burner (left or right option).

Refer to data plate when installing.

Venting

The Fire Deck 6045 must be vented using a Listed Type 1 exhaust hood, or a hood constructed and installed in accordance with NFPA 96 and all relevant local and national codes. The oven must be vented in accordance with all relevant local and national codes, and in a manner acceptable to the authority having jurisdiction.

Important: Models with -W in the model number must be vented as a solid fuel appliance.

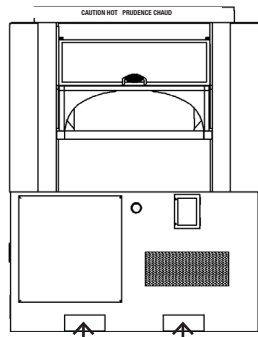

Front Forklift / Pallet Jack Pockets

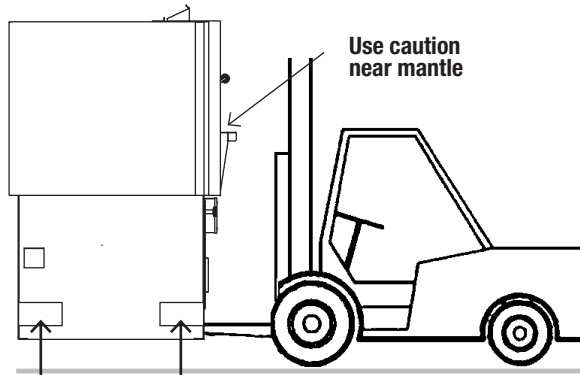

Side Forklift Pockets

Shown:
Left-hand configuration

⚠ WARNING Minimum Required Forklift Capacities	
5' FORKS MINIMUM	
Model	Lifting from Front, Rear or Sides
FD-6045	6,000 lbs

USING A FORKLIFT

The Wood Stone Fire Deck 6045 weighs approximately 3,200 lbs. and is top-heavy.

Use a forklift with adequate fork lengths and lifting capacity. When using a forklift, always use the forklift pockets. Lifting the oven any other way with a forklift may result in damage. Use extreme caution and make sure that the forks extend all the way through the pockets provided. Fork length must be at least 5' long. If it is necessary to approach the oven from the front, be sure the mast does not contact the mantle (shelf).

There are fork pockets at the front and sides of the oven.

Once the oven is on a **smooth, flat** floor it can be rolled on its optional heavy-duty, temporary shipping Casters (details next page).

USING A PALLET JACK

The oven may also be moved with a Pallet Jack using the front or rear fork pockets only. Once the oven is on a **smooth, flat** floor it can be rolled to its final position. **DO NOT ATTEMPT TO MANUALLY ROLL THE OVEN UP OR DOWN A RAMP OR INCLINE.** Do not position yourself between the moving oven and an immovable object or surface such as a wall or door frame.

DO NOT TURN THE OVEN ON ITS SIDE!

Moving a Wood Stone oven can present interesting challenges to even the most experienced riggers. Make sure to secure the proper equipment and make safety your first priority. Please don't hesitate to call the factory for technical support.

USING A CRANE

If you are planning to use a crane to unload the oven, specify a flatbed truck delivery.

Use the pickeys provided on the sides of the oven to lift the oven with a crane. The spreader bar should be of a sufficient length to keep the sling from contacting the oven, and oriented as shown in fig. 1.

DELIVERY NOTE

The customer will receive an Oven Shipping Notification when the oven leaves the Wood Stone factory. This will include a PRO# and a trucking company contact number. Wood Stone recommends that you confirm the delivery date/time with the trucking company before committing to heavy equipment and/or labor. Our goal is a smooth and safe delivery.

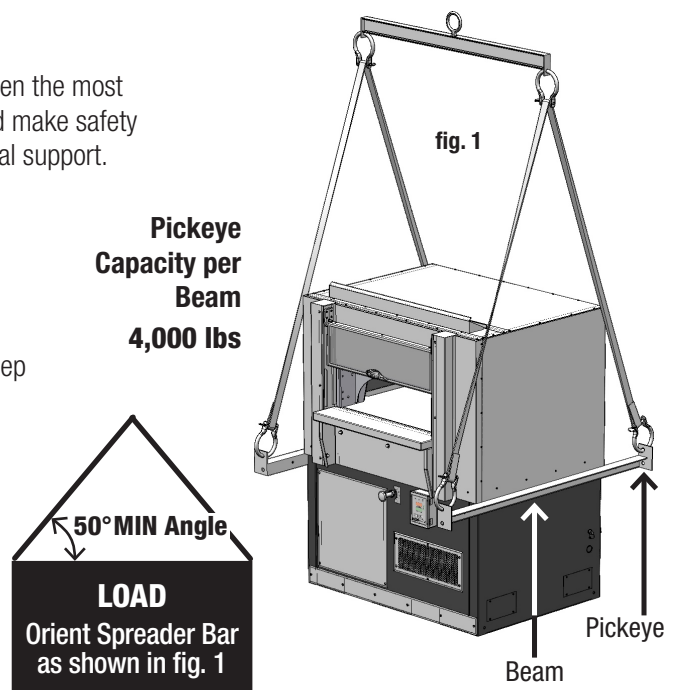



INSTRUCTIONS FOR INSTALLING AND REMOVING OPTIONAL OVEN CASTERS

The Fire Deck 6045 weighs approximately 3,200 lbs.

Do not attempt to move the oven over any type of grade or sloped surface when using the Casters or Pallet Jack.

WARNING: Failure to follow these instructions may result in severe injury or death.

If you have any questions call Wood Stone at 800.988.8103.

NOTE: The casters will add 3" to the total height of the oven, for a total of 81-1/4".

The 3-3/4" Vent Shield on top can be removed temporarily if necessary.

Shipping Casters are for moving the oven only. **THEY MUST BE REMOVED ONCE THE OVEN IS IN PLACE.**

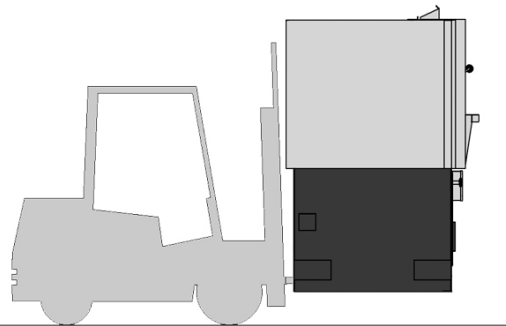

- 1** Use a forklift (or pallet jack) to raise the oven using the front or rear forklift pockets.



- 2** Insert a Caster Assembly into each of the side fork pockets and secure it to the oven with a Self-Drilling Screw and washer.
- Install the screw through the Mounting Tab.
- Once the Caster Assemblies are installed, lower the oven.
- It may then be rolled over a **smooth flat** surface to its final destination.

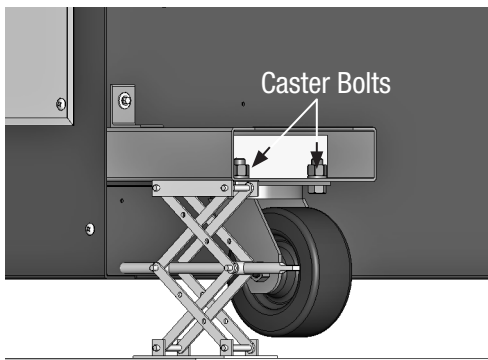

- 3** Once at final destination, use two scissor jacks (or pallet jack) to lift the one side of the oven by placing one jack under each caster assembly.
- Raise the oven just high enough so the wheels clear the floor.
- Unbolt each Caster and remove it.

Note: Casters are for moving oven only. They must be removed once the oven is in place.

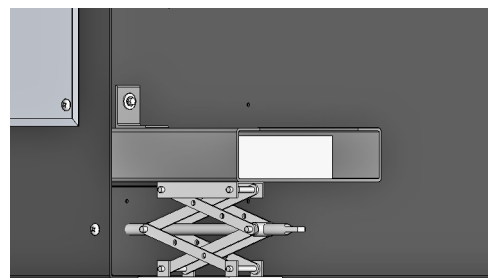

- 4** Lower the oven back to the ground.
- Remove the Self-Drilling Screw and slide the rest of the Caster Assembly out of the fork pocket.
- Install Fork Pocket Covers
- Repeat steps **3** and **4** for the other side of the oven.
- This oven is designed to be sealed to the floor upon installation using a silicone sealant acceptable to the local health official. See the Placing & Installation section of this manual for additional instructions.



PLACING THE OVEN

The oven must be installed on a flat level surface. The weight of the oven is carried by the full perimeter of the oven stand. If it is necessary to shim the oven for leveling purposes, it is critical that the shim material be metal, and that the shims are installed in such a way that the full perimeter of the stand is solidly supported. Any gaps created by shimming between the oven and the floor must be sealed (using a silicone sealant acceptable to the local health official) to prevent airflow issues beneath the oven. **Failure to solidly support the full perimeter of the oven stand can result in costly damage to the oven and will void the warranty.** The floor design and construction must be adequate to handle the weight of the oven.

See woodstone-corp.com for floor loading information.

TOE KICK AND FORK POCKET COVERS

Once the oven is in place, the Toe Kick must be installed along the front, and the Fork Pockets on the sides and back of the oven using the screws provided. The area under the oven must be enclosed in order to prevent pests from entering this space and to prevent air flow issues which can detrimentally effect burner operation.

FACADE READY OVENS: If the lower front of the oven is shipped facade ready, the toe kick will not be included. Instead, fork pocket covers and pre-cut blocks of cement board to cover the pocket covers will be included.

If the sides and/or rear of the oven is shipped facade ready, the Fork Pocket Covers will not be included. Pre-cut blocks of cement board or other facade material will be shipped instead of the Fork Pocket Covers. The blocks must be inserted into the fork pockets before the oven facade is put in place.

IMPORTANT: The equipment is required to be sealed to the floor to establish proper sanitary operation. Seal any small gaps between the oven and the floor with silicone. This is intended to prevent liquid spillage on adjacent surfaces of the floor from passing under inaccessible portions of the equipment.

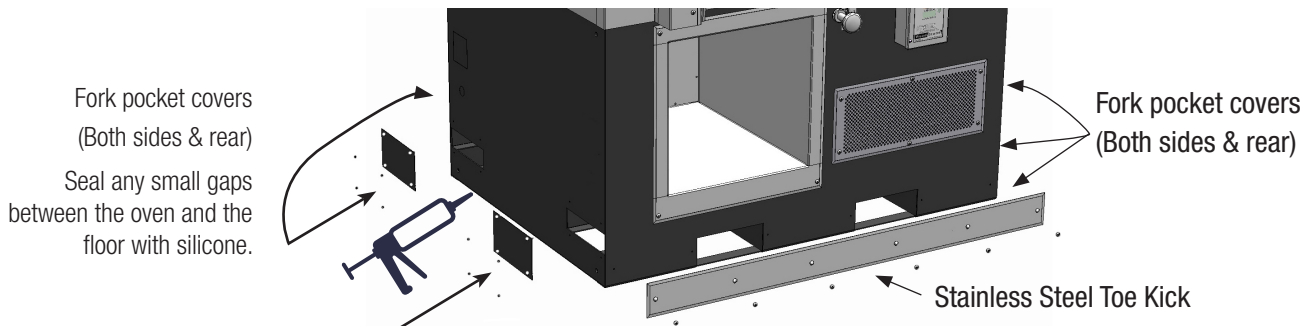

FORK POCKET COVER INSTALLATION

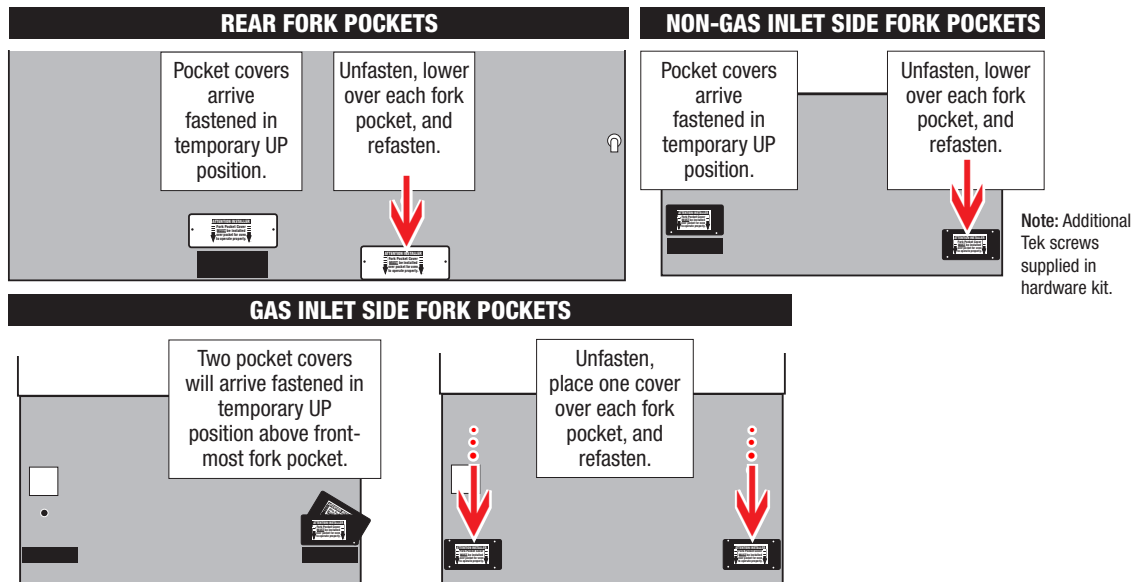



WARNING: Do not pack required air spaces (clearance) with insulation or other material. When non-combustible building materials contact the body of the oven, the clearances to combustibles are transferred to those non-combustibles.

TO REDUCE THE RISK OF FIRE, FOLLOW THESE INSTALLATION INSTRUCTIONS. A MAJOR CAUSE OF OVEN RELATED FIRES IS FAILURE TO MAINTAIN REQUIRED CLEARANCES (AIR SPACES) TO COMBUSTIBLE MATERIALS. IT IS OF UTMOST IMPORTANCE THAT THIS OVEN BE INSTALLED ONLY IN ACCORDANCE WITH THESE INSTRUCTIONS.



WARNING: Installation and servicing of this product could expose you to glasswool/ceramic fibers as well as calcium silicate dust. **ALWAYS WEAR RESPIRATORY AND EYE PROTECTION WHEN INSTALLING OR SERVICING THIS APPLIANCE.** Please read this entire manual before you install the oven. Failure to follow instructions may result in property damage, bodily injury or even death. Contact your local building or fire officials about restrictions and installation inspection in your area.

1. The Wood Stone Fire Deck oven must have a minimum 1-inch clearance to combustibles from all sides, and 24-inch clearance to combustibles from the top. If building materials will contact the oven, they must be completely non-combustible. Please note that standard Drywall (or Sheetrock) is considered a combustible. When non-combustible building materials contact the body of the oven, the respective clearances are transferred to those non-combustibles.
2. Any facade 6 inches to either side of the oven doorway or above, must be constructed of non-combustible building materials.
3. **For gas-only models**, this oven is suitable for installation on combustible floors (convient à l'installation sur un plancher combustible).

For gas/wood combination models, this oven is suitable for installation on combustible floors (convient à l'installation sur un plancher combustible). The minimum hearth extension area to be covered with a non-combustible floor surface must extend 36 inches in front of and 30 inches to either side of the oven door opening.

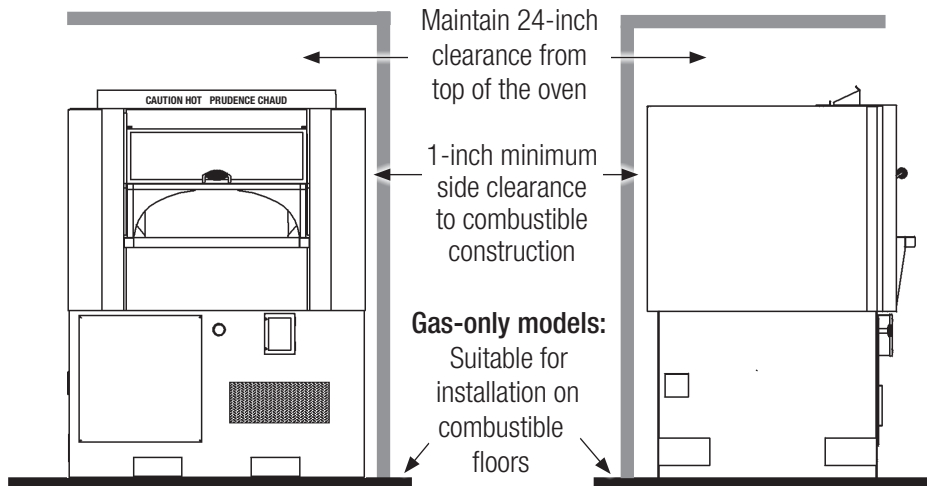

Gas/wood combination models: This oven is suitable for installation on combustible floors (convient à l'installation sur un plancher combustible). The minimum hearth extension area to be covered with a non-combustible floor surface must extend 36 inches in front of and 30 inches to either side of the oven door opening.



If planning a decorative facade for the front of the oven, please refer to the diagram below.

Any facade materials that contact the oven must be noncombustible.

Failure to follow the instructions above may void the oven warranty.

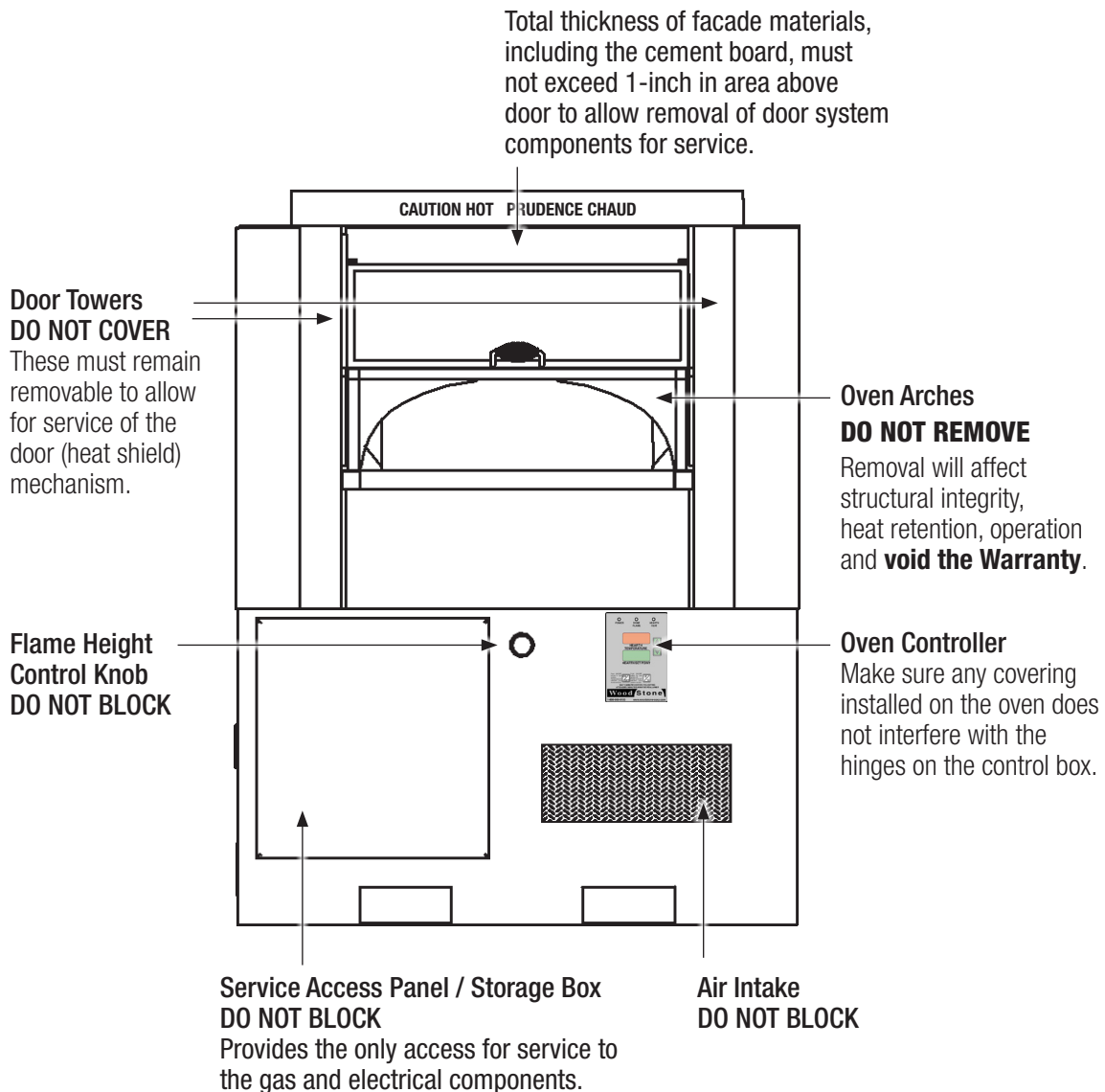

ABOUT FACADE MATERIALS

Fire Deck Series ovens can be finished with any non-combustible decorative material that can be easily affixed to the oven surface, including tile, stone or brick. It is always advisable to consult with the appropriate authority having jurisdiction before proceeding as there may be regulations regarding the suitability of various materials. Temperatures above the oven doorway can reach over 200 °F. Select materials and adhesives suitable for that temperature.



The Facade Ready Fire Deck features cement board already installed on the front surfaces of the oven. **ANY MATERIALS AFFIXED TO THE CEMENT BOARD MUST BE NONCOMBUSTIBLE.**

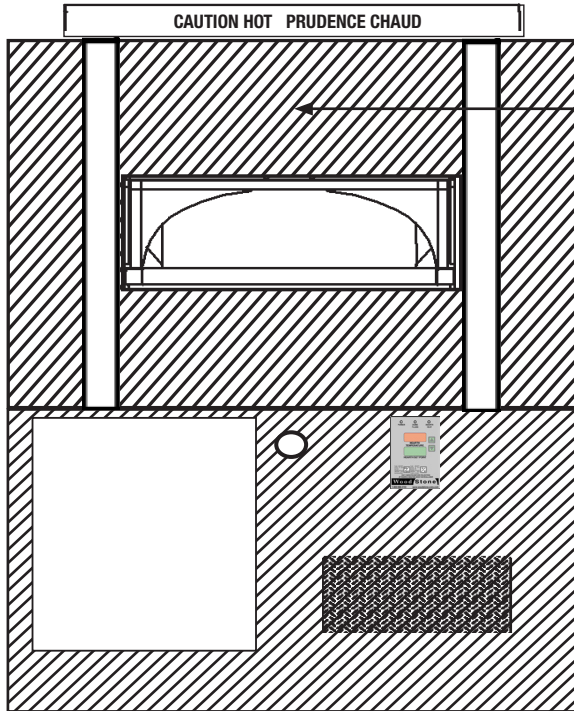

Total thickness of facade materials, including the cement board, should not exceed 1-inch in thickness in area above the door to allow removal of door system components for service.



The hatched area represents surfaces of the oven that are covered with cement board at the factory. All parts of the oven which are meant to be left exposed are not hatched (see previous page).

Tile or other noncombustible, sanitation approved facade material (supplied by others).

1-inch stainless steel perimeter lip



A 1-inch wide stainless steel lip is provided, around the doorway opening and around the air intake vent. This is provided so that the noncombustible, sanitation approved materials used to cover the cement board can be neatly terminated at these points.



The Wood Stone Fire Deck must be vented using a Type 1 exhaust hood, or one constructed and installed in accordance with NFPA 96 and all relevant local and national codes. Wood Stone offers exhaust hoods especially designed for the Fire Deck by Gaylord Industries (see HOOD SPECIFICATIONS section).

Fire Deck model numbers containing a -W (other than the “W” in the beginning of the model number) should be vented in accordance with codes concerning solid fuel appliances (NFPA 96). Due to the dangers of creosote buildup and of sparks entering the duct, these models must be vented separately from all other kitchen equipment.

Solid fuel exhaust contains creosote and other substances that accumulate in ducting, creating a risk of fire. The rate of accumulation will vary with respect to flue gas temperature, wood type and moisture content. Frequent, regularly scheduled, thorough flue cleaning is the best way to minimize the risk of flue fires. **Wood Stone recommends cleaning and inspection at least monthly on any ventilation system serving solid fuel equipment.**

OVENS THAT BURN WOOD: CREOSOTE - AND THE NEED FOR ITS REMOVAL

When wood is burned slowly, it produces tar and other organic vapors, which combine with expelled moisture to form creosote. The creosote vapors condense in the relatively cool oven flue of a slow-burning fire. As a result, creosote residue accumulates in the duct. When ignited, this creosote makes an extremely hot fire. The duct serving this oven should be inspected at least twice a month during the first two months of operation, to establish rate of creosote buildup and necessary cleaning schedule. If creosote or soot has accumulated, it should be removed to reduce the risk of a flue fire. The interior floor and dome of the oven do not require creosote or soot removal. The oven flue and exhaust system will require inspection and cleaning. **Wood Stone recommends cleaning and inspection at least monthly on any ventilation system serving solid fuel equipment.** The exhaust system should be inspected and cleaned per the manufacturer's and or local code official's recommendations.

WOOD STONE RECOMMENDS THAT THE OPERATOR REFER TO THE EXHAUST HOOD MANUFACTURER'S INSTRUCTIONS FOR INSPECTION, MAINTENANCE AND CLEANING. WOOD STONE RECOMMENDS THAT YOU SUBMIT YOUR VENTING PLANS TO THE AUTHORITY HAVING JURISDICTION BEFORE PROCEEDING WITH INSTALLATION OF ANY GAS AND/OR SOLID FUEL BURNING APPLIANCE.

FIRE SUPPRESSION: WOOD-FIRED OVENS

This oven must be vented with a Type 1 exhaust hood constructed and installed in accordance with NFPA 96. The Type 1 hood must be equipped with fire suppression per NFPA 96. The fusible link in the hood must be rated at 450 °F minimum. Wood Stone offers Listed exhaust hoods for our ovens that are pre-piped for ANSUL R-102 fire suppression. All installations are subject to the approval of the local authority having jurisdiction.

FIRE SUPPRESSION: GAS-FIRED OVENS

This oven must be vented with a Type 1 exhaust hood constructed and installed in accordance with NFPA 96. The Type 1 hood must be equipped with fire suppression per NFPA 96. The fusible link in the hood must be rated at 450 °F minimum. Wood Stone offers Listed exhaust hoods for our ovens that are pre-piped for ANSUL R-102 fire suppression. **Wood Stone does not recommend aiming any fire suppression nozzles into the cooking chamber of the oven.** All installations are subject to the approval of the local authority having jurisdiction.



Wood Stone Hoods by Gaylord Specifications
Required CFM: 730 CFM
Static Pressure: 0.80" W.C.
Duct Collar: 7.5"x 7.5" I.D.

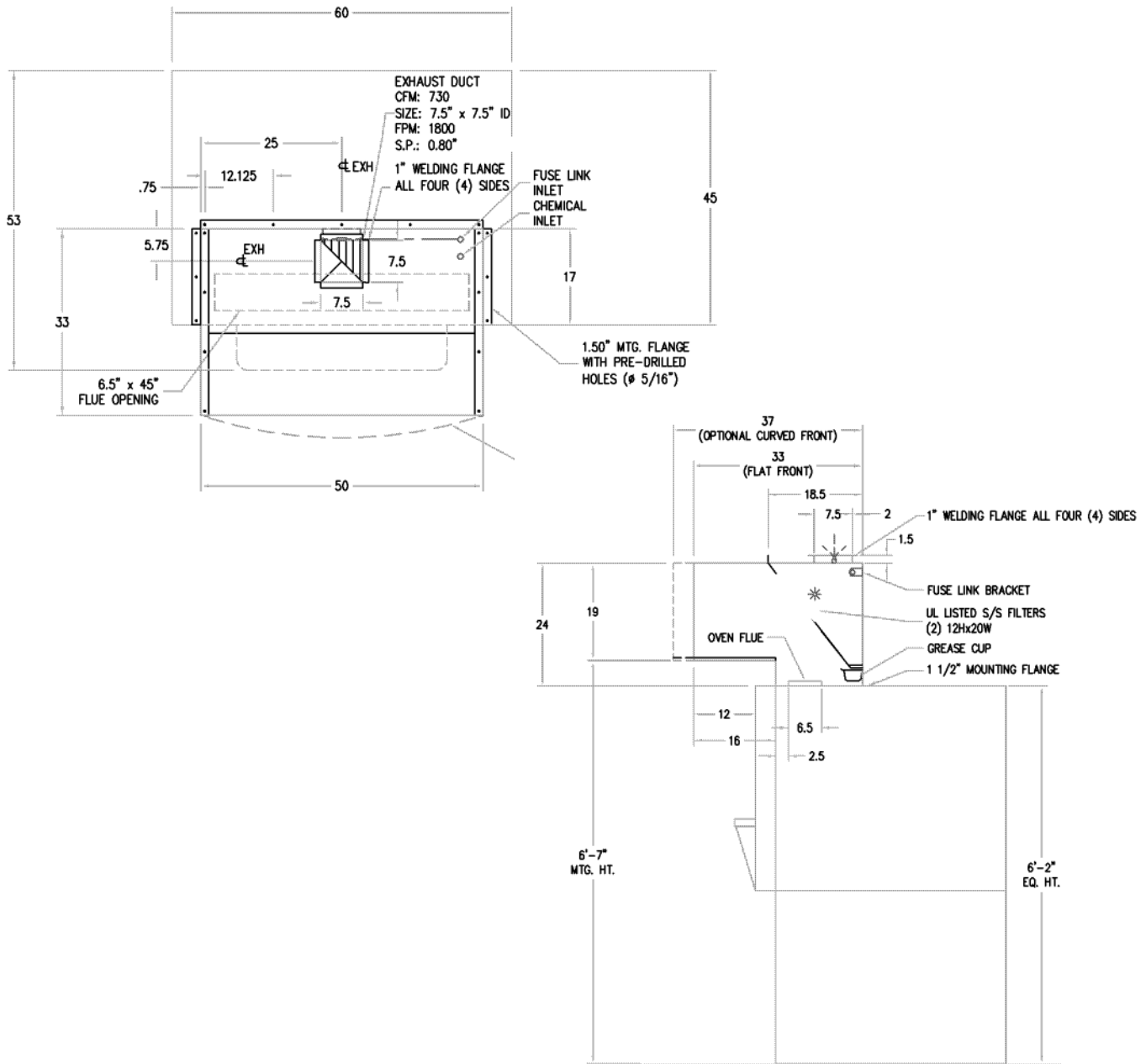



FACTORY SPECIFIED MAXIMUM HOURLY BTU INPUT RATES / BURNER MANIFOLD PRESSURES

Model number	Underfloor IR Burner	Left Side Burner	Right Side Flame Burner	Wood Fire Optional	Wood Fire Mandatory	Optional Decorative Flame	Natural Gas (NG)	Propane (LP)	Propane (HLP)	Maximum Gas BTU/hr Input	Valve Outlet Pressure (W.C.)		
											SV-1	SV-2	
WS-FD-6045-RFG-(L or R)-IR-W	X	L or R		-W			NG			160,000	3.5"	4.25"	
								LP			8"	8"	
									HLP		135,000	7.5"	8"
WS-FD-6045-RFG-(L or R)-IR	X	L or R					NG			160,000	3.5"	4.25"	
								LP			8"	8"	
									HLP		135,000	7.5"	8"
WS-FD-6045-RFG-(L or R)		L or R					NG			90,000		4.25"	
								LP			75,000		8"
									HLP		90,000		8"
WS-FD-6045-IR-W	X				X		NG			45,000	3.5"		
								LP			50,000	8"	
									HLP		50,000	8"	
WS-FD-6045-W					X				NA		NA		
Optional Decorative Flame Burner <i>The Optional Decorative Flame Burner adds 15,000 BTU/hr to total rated input.</i>						-DF	NG			+15,000		5"	
								LP			8"		
									HLP	not available			

This oven requires no modifications or adjustments for use at high altitudes.

The installation of this appliance must conform with local codes, or in the absence of local codes, with the National Fuel Gas Code, ANSI Z223.1 or The Natural Gas Installation Code CAN/CGA-B149.1 as applicable.

SV-1 is the gas control valve that operates the Underfloor IR Burner. The manifold pressure is checked at the outlet port on the SV-1 gas valve.

SV-2 is the gas control valve that operates the interior Radiant Burner. The manifold pressure is checked at the outlet port on the SV-2 gas valve.

The burner manifold pressures have been adjusted and tested at the factory. A variety of factors can influence these pressures, so be sure to test the individual burner manifold pressures and adjust the valves as necessary to achieve the required pressures.

NOTE: The gas valves are shipped in the **ON** position.



GAS CONNECTION

The Wood Stone Fire Deck 6045 is equipped with a 3/4-inch FNPT gas connection (see page 17 for exact location). Have a licensed gas installer provide the hookup and test all fittings and pipe connections for leaks. Use approved gas leak detectors (soap solutions or equivalent) over and around the fittings and pipe connections. **DO NOT USE FLAME TO TEST FOR LEAKS!**

All gas piping up to the oven must have a minimum inside diameter of 3/4", including all fittings and shut off valves, which should be of the full flow type.

Wood Stone recommends that the Fire Deck be equipped with a manual, individual shutoff valve, located between the oven and the main gas supply, and that this shutoff valve (supplied by others) be left readily accessible. Wood Stone also recommends that inspection and maintenance of the burners and gas piping connections of this appliance be performed at regularly scheduled intervals and only by professional gas appliance service agencies.

Maximum inlet gas pressure must not exceed 14" W.C. (1/2 psi)

GAS INLET PRESSURE

For ovens running on natural gas, an inlet pressure of 7 to 10" W.C. is recommended to ensure optimum oven performance. Incoming gas pressure below this range will affect oven performance, the lower the pressure the greater the negative impact. If the gas supply pressure is greater than 14" W.C. (1/2 psi), an external regulator, supplied by others, is REQUIRED to lower the gas pressure to the acceptable range. Issues caused by low or high gas pressure are installation issues, and will not be covered under the Warranty.

For ovens running on Propane (LP or HLP), the recommended inlet pressure to ensure optimum oven performance is 10 to 12" W.C. Incoming gas pressure below this range will affect oven performance, the lower the pressure the greater the negative impact. If the gas supply pressure is greater than 14" W.C. (1/2 psi), an external regulator, supplied by others, is REQUIRED to lower the gas pressure to the acceptable range. Issues caused by low or high gas pressure are installation issues, and will not be covered under the Warranty.

For all installations, follow best practices for proper gas line pipe sizing for the line serving the oven. To ensure proper operation, all gas piping and fittings leading up to the oven should have an inside diameter equal to or greater than that of the oven gas connection. Also make sure that a readily accessible shut off valve (supplied by others) is installed near the oven, and in accordance with all applicable codes. Shut off valves must be of the full-flow type, and not introduce any restriction into the gas line.

The connection to the oven should be hard-piped whenever feasible. If this is not possible, use a properly sized flexible connector approved for this application. When using a flexible connector make sure that its design does not present any reduction in pipe diameter or other restriction. Oven issues caused by improper pipe sizing, improper shut off valves, restrictive connectors, or any other deficiency in the gas supply design or installation will not be covered under the oven warranty.

GAS CODE LIMITATIONS

The installation of this appliance must conform with local codes, or in the absence of local codes, with the National Fuel Gas Code, ANSI Z223.1 or The Natural Gas Installation Code CAN/CGA-B149.1 as applicable.

The appliance and its individual shutoff valve (supplied by others) must be disconnected from the gas supply piping system during any pressure testing of that system at test pressures in excess of 1/2 psi (14" W.C.) (3.45 kPa).

The appliance must be isolated from the gas supply piping system by closing its individual manual shutoff valve (supplied by others) during any pressure testing of the gas supply piping system at test pressure, equal to or less than 1/2 psi (14" W.C.) (3.45 kPa).



NORTH AMERICAN MODELS

Have a licensed electrician provide the oven with appropriate 120 VAC circuit, 1.1 A required, in accordance with all relevant local and national codes. Electrical diagrams are located on the back side of the oven as well as at the end of this manual. Always check the equipment data plate beneath the oven to verify the proper voltage requirement.

OUTSIDE NORTH AMERICA

Ovens shipped outside of North America may be configured for 240 VAC, 1 A required in accordance with all relevant local and national codes. Electrical diagrams are located on the back side of the oven as well as at the end of this manual. Always check the equipment data plate beneath the oven to verify the proper voltage requirement.

CONNECTION LOCATION

The electrical connection is made in the recessed junction box, located on the left side of the oven (toward the rear). There is a hole in the rear of the oven (equipped with a flex conduit elbow connector) through which the incoming electrical service should be run.

ELECTRICAL CODE LIMITATIONS

Electrical Grounding: This appliance must be electrically grounded in accordance with local codes, or in the absence of local codes, with the National Electrical code, ANSI/NFPA 70 or the Canadian Electrical Code, CSA C22.1 as applicable.

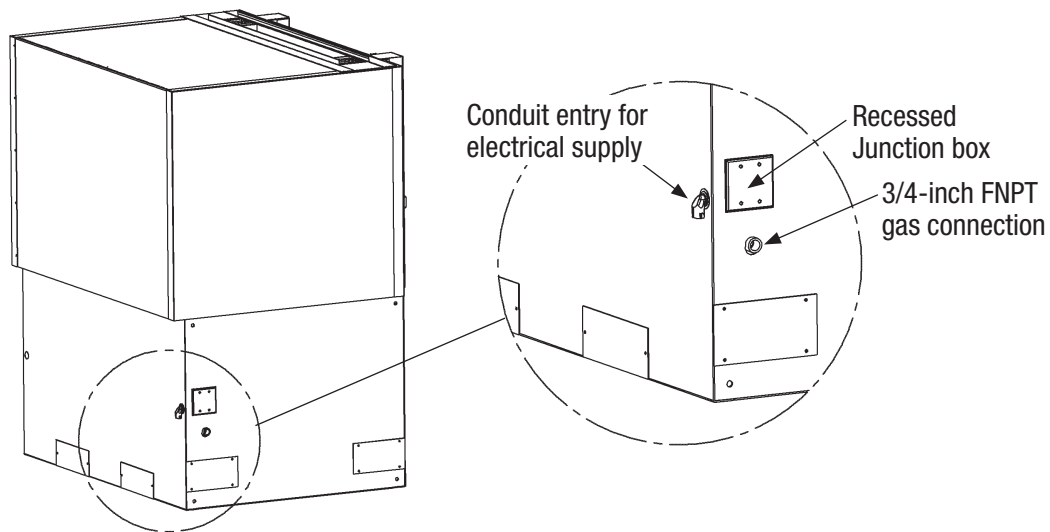



CONTROLLER FUNCTIONS

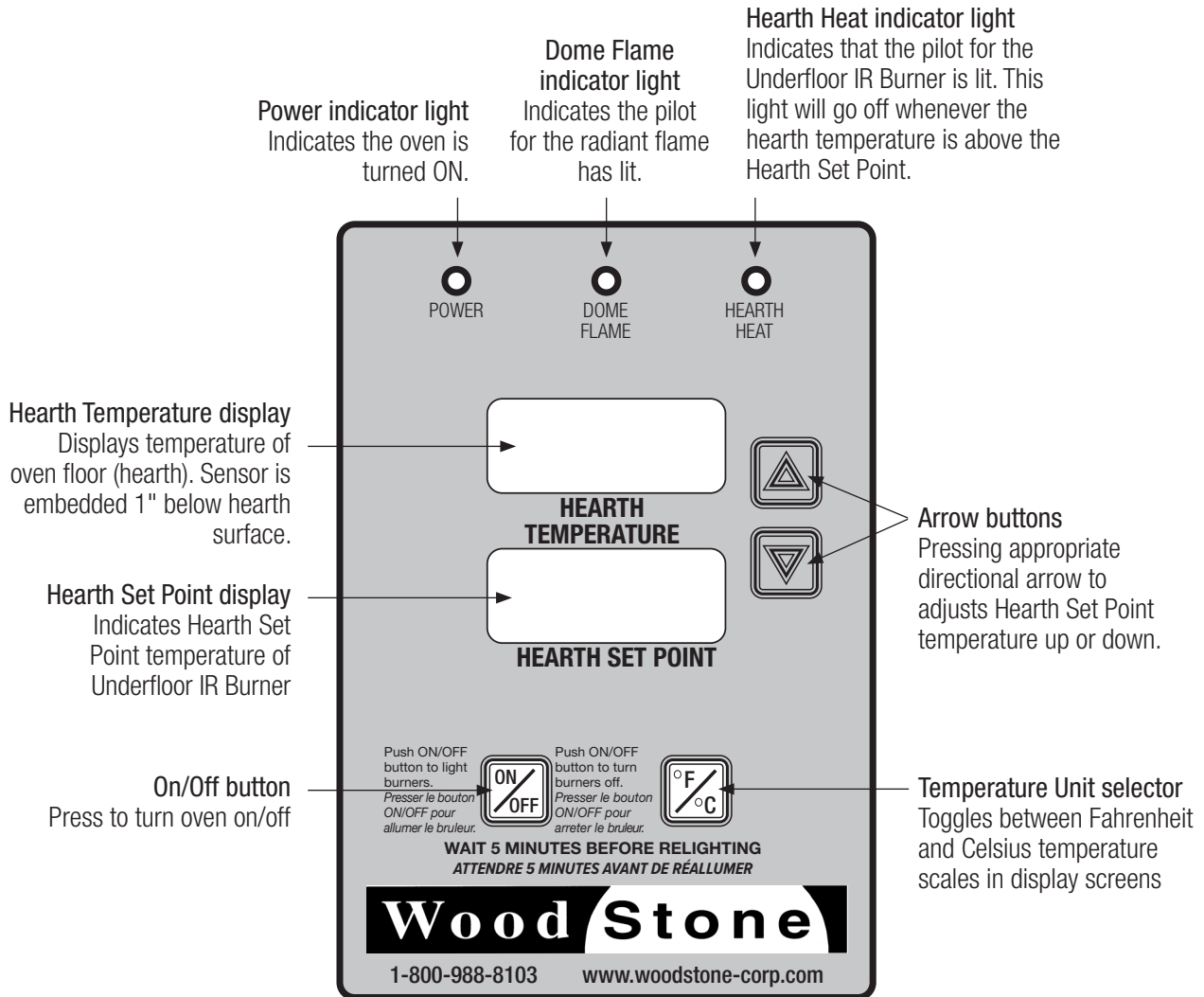



INITIAL OVEN START-UP

Your oven was cured at the factory. However, in the course of shipment, storage on-site, etc. the ceramic materials will have absorbed moisture. It is critical that the initial oven startup procedure below be followed to ensure that this moisture is driven from the ceramic in a controlled fashion. This will minimize cracking and prevent damage to the oven that could otherwise occur by bringing the oven to temperature rapidly the first time it is used. This initial oven start-up procedure needs only be followed the first time the oven is fired and/or if the oven has not been used for an extended period of time.

FIRST DAY

1. Make sure main gas supply is on (valve parallel with gas line).
2. Make sure the switch on the Honeywell control gas valve is in the ON position.
3. Push ON/OFF button on Controller. It may take a while for the gas to purge all the air from the gas lines.
4. Allow oven to operate at factory settings for 1 hour (Hearth Set Point at 100 °F; radiant flame at lowest setting).
5. After one hour, raise radiant flame to ~4–5" flame (25% of maximum flame height). Hold this setting for 4 hours.
6. After 4 hours at 25% flame height, raise to 50% flame height and hold for at least another 4 hours until the temperature reaches 500 °F.
7. Push ON/OFF button to turn oven off. All gas and pilots will go off.

NEVER PLACE ANYTHING IN OR ABOVE THE RADIANT FLAME

ADJUSTING THE RADIANT (DOME) FLAME

The radiant flame is/are always on when the oven is operating. To adjust between the highest and lowest intensity, turn the Flame Height Control Knob located on either side of the Controller. This burner is the primary heat source for the oven. The Underfloor IR Burner (if equipped) acts only as an assist to maintain desired floor temperatures during periods of very high food production.

HOW TO ADJUST THE FLOOR TEMPERATURE (HEARTH SET POINT)

Fire Deck ovens equipped with an infrared, Underfloor IR Burner have an adjustable Hearth Set Point. To adjust the oven's thermostatic floor temperature setting, the Hearth Set Point, press the up or down arrow buttons. If the thermostatic Hearth Set Point is raised **above the actual** Hearth Temperature, the Underfloor IR Burner will activate (and the Hearth Heat Indicator Light will light).

It is possible to program the floor's thermostatic Hearth Set Point to temperatures from 100–800 °F. Once proper temperatures for your application have been established, there should be little or no need to change the Hearth Set Point.

HOW TO READ FLOOR TEMPERATURE

The floor temperature is continuously displayed by the Controller in the window labelled "Hearth Temperature". This reading is being taken by a thermocouple about an inch below the floor surface, so the actual surface temperature may be somewhat different, and is best measured using a non-contact (IR) thermometer.

NOTE: Small "crazing" cracks will occur with normal heating and cooling. They will not effect the performance or durability of the oven. If cracks of 1/8 inch or more in width develop, contact Wood Stone for evaluation.



GENERAL DAILY OVEN OPERATION

BEGINNING OF THE DAY

Push ON/OFF button, set Controller to desired floor temperature and turn the radiant flame to its highest setting. The oven should stabilize at your desired temperature typically within 1–2 hours. Go to woodstone-corp.com for detailed information on cooking in your Wood Stone oven.

CLEANING THE OVEN

Wood Stone recommends the use of long-handled brushes for sweeping up surface debris that will accumulate on the floor of the oven during use. Use a natural fiber brush, always brushing away from the Radiant Burner well. For deeper cleaning, use a brass bristled brush. The oven floor can be then cleaned with a damp rag wrapped around the brush head. **Take care not to brush debris into the radiant flame burner(s).**

Wood Stone offers an assortment of oven brushes available through your dealer. Specification sheets may be viewed on the Wood Stone website under Tools & Accessories.

DETAILED DAILY OVEN OPERATION

IMPORTANT: If at any time you feel that any of the burners are not operating properly, turn the oven off and call for service. Before servicing, disconnect the electrical supply at the breaker and turn off the gas supply at the appliance's individual gas shutoff valve. In the event of a power failure, no attempt should be made to operate the oven.

DAILY STARTUP

Press the ON/OFF button to start the oven. The radiant flame will ignite. The Underfloor IR Burner (if equipped) will ignite if the actual floor temperature is below the Hearth Set Point temperature to which the Controller is adjusted. See Controller section in this manual.

Power: Indicates the system is energized.

Dome Flame Light: Indicates the pilot flame for the Radiant Burner is (are) lit.

Hearth Heat Light: Indicates that the pilot flame for the Underfloor IR Burner is lit. This light will go off whenever the actual floor temperature is above the thermostatic Hearth Set Point.

TURNING OFF THE OVEN

Push the ON/OFF button on the Controller to turn the oven off. The burner will go out and the digital readout on the Controller will go blank.

ALWAYS WAIT 5 MINUTES BEFORE ATTEMPTING TO RELIGHT THE OVEN



DETERMINING THE APPROPRIATE FLAME HEIGHT

For each specific configuration of oven there is a system that determines what the desired flame height will be. Each flame height corresponds to a saturated floor temperature. Several factors need to be accounted for in order to determine this relationship for each oven.

FLAME HEIGHT & COOKING ZONES

Heat Up Flame: Set the Flame Height Control Knob(s) to “5” (highest setting) on the Flame Height Index Scale until desired temperature is reached, then turn both flames down to the appropriate Holding flame.

Holding Flame: Set the Flame Height Control Knob(s) to “3” (~6–7 inch flame) on the Flame Height Index Scale for a desired temperature of 450–480 °F.

Cooking Flame: After introducing the pizza/product into the oven, visually raise the flame approximately 3 inches higher than the Holding Flame. This now becomes the hottest side of the oven, **the Searing Zone**. Pizzas will be landed on the opposite side of the oven from this Cooking Flame, **the Landing Zone**, and finished in the area between the **Searing and Landing Zones**—the **Finishing Zone**.

Return to Holding Flame height after removing pizza/product from the oven.

NOTE: Visually measure each suggested flame height using the Wood Stone utility peel, which is 8" tall when standing on edge in front of the flame. Then relate height to the corresponding number on the Flame Height Index Scale.

THE COOKING FLAME HAS TWO PURPOSES

1. To help bake the top of the pizza/product as fast as the bottom of the pizza/product.
2. To help replace heat to the floor (hearth) that is lost during production cooking.

NOTE: The settings recommended on the Flame Height Index Scale for specific flame heights are based on ovens that have been installed according to specifications. Individual results may vary slightly.

FLAME HEIGHT INDICATOR

Comprised of two parts

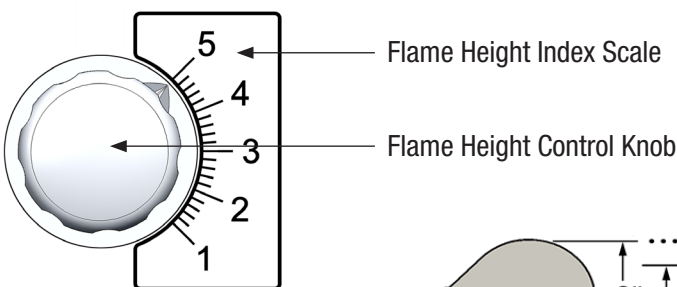

Note: Flame Height Index Scale may be positioned on left side of Flame Height Control Knob on some configurations.

For more information regarding Flame Height Control, go to the Resource Center section of the Wood Stone web site at:
www.woodstone-corp.com

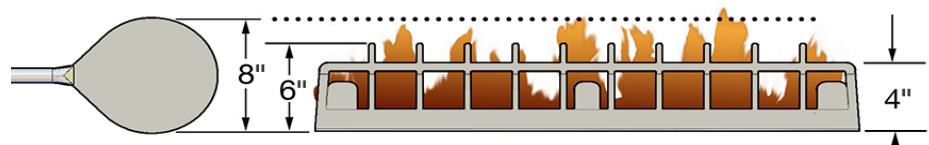

TIP: You can visually estimate flame heights using the Wood Stone utility peel, which is 8" tall when standing on edge in front of the flame. Then relate height to the corresponding number on the Flame Height Index Scale.

**FIRE DECK MODELS LISTED FOR WOOD BURNING WILL HAVE A “-W” IN THE MODEL NUMBER.**

When burning wood in a Wood Stone Fire Deck, the fire should be located on the side of the oven chamber opposite the radiant gas burner. Wood may be burned at a rate not to exceed 15 lbs. per hour. Two models, WS-FD-6045-IR-W and WS-FD-6045-W, have no Radiant Burners—wood may be burned on both sides of the oven chamber simultaneously. **DO NOT OVER FIRE.** If flames exit the doorway or exhaust opening, or if oven deck temperature exceeds 850 °F, you are over firing.

Make every effort to keep ash and other debris out of the Radiant Burner well. Do not use the Radiant Burner as a “backstop” when shoveling ash and/or coals out of the oven. Using the oven floor brush and ash shovel, remove coals and ash through the oven doorway and dispose of safely.

**USE SOLID
WOOD FUEL
ONLY. DO NOT
USE PRODUCTS
NOT SPECIFIED
FOR THIS OVEN.**

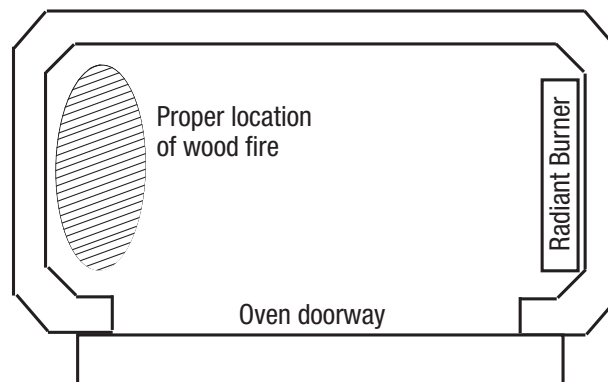

NOTE: Two models, WS-FD-6045-IR-W and WS-FD-6045-W, have no Radiant Burners—wood may be burned on both sides of the oven chamber simultaneously.

Wood should be stored and handled in accordance with the recommendations outlined in NFPA 96. The interior floor and dome of the oven do not require creosote or soot removal. The oven flue and exhaust system will require inspection and cleaning. The exhaust system should be inspected and cleaned per the manufacturer's and or local code official's recommendations. **Wood Stone recommends cleaning and inspection at least monthly on any ventilation system serving solid fuel equipment.**

DISPOSAL OF ASHES

Dispose of ash per the following: place ashes into a metal container with a tight fitting lid. The closed container of ashes should be placed on a non-combustible floor or on the ground, well away from all combustible materials, pending final disposal. They should be retained in the closed container until all the cinders have thoroughly cooled. Ashes can then be disposed of safely.

Wood Stone's stainless steel ash shovel and Double Compartment Ash Dolly disposal system is a safe and convenient way to dispose of ash. See specifications on woodstone-corp.com or call your dealer or Wood Stone for details.

DO NOT USE THE RADIANT BURNER TO IGNITE WOOD OR SUPPORT THE WOOD FIRE.

NEVER USE GASOLINE, GASOLINE-TYPE LANTERN FUEL, KEROSENE, CHARCOAL LIGHTER FLUID OR SIMILAR LIQUIDS TO START OR FRESHEN UP A FIRE IN THIS OVEN. KEEP ALL SUCH LIQUIDS AWAY FROM THE OVEN WHEN IN USE.



OVEN INTERIOR

Wood Stone recommends the use of a long-handled, brass bristled brush for sweeping aside excess food particles that will accumulate on the floor of the oven during use. The oven floor can be cleaned with a damp rag.

DO NOT POUR OR SPRAY LIQUIDS ONTO THE OVEN DECK OR INTO THE OVEN INTERIOR AS THIS CAN DAMAGE THE CERAMIC AND WILL VOID THE WARRANTY.

There is a stainless steel guard on each Radiant Burner to prevent food from falling on and thereby obstructing the gas orifices of the radiant flame. If food gets into the radiant flame well and the flame is visibly obstructed, turn the oven OFF, and call for service.

OVEN EXTERIOR

All exposed stainless steel, surfaces should be cleaned as necessary using a mild detergent, hot water and a soft cloth or sponge. Stubborn residues may be removed using a nonmetallic scouring pad. **When scouring stainless steel surfaces, scrub with the grain of the metal to prevent scratching.**

IMPORTANT: Do not use excessive amounts of liquid when wiping on or around the control box. Also do not use the Radiant Burner well as a dump for debris or trash incineration; make every effort to keep debris from dropping into the well.

CLEANING THE HEAT SHIELD DOOR

The glass heat shield is designed to allow for easy cleaning. **It should be cleaned daily.** The front of the heat shield can be cleaned in the lowered position using a soft cloth and mild soap and water solution.

To clean the back of the glass, first raise the shield to its up position. The shield can then be rotated up and over the roller blocks as shown, which will support the shield in this position, allowing the back to be cleaned. Rotate back to the front for normal operation.

CAUTION: Do not use abrasive pads, which may etch or fog the glass. Avoid excessive water. Prevent dripping onto the ceramic hearth of the oven by placing sheet pans in the doorway to catch drips.

For excessive build up on glass, oven cleaner may be used as necessary, following manufacturer's instructions. Take **extreme** care to prevent dripping onto the ceramic hearth by placing sheet pans in the doorway to catch drips.

CAUTION: Many oven cleaners are flammable—turn off oven while cleaning.



Shown: FD-8645

Sheet pans

ESTABLISHING A THERMAL CLEANING SCHEDULE

Wood Stone ovens are typically operated at temperatures which preclude the need for cleaning of the interior walls and ceiling (the dome) of the oven. If however, you routinely operate the oven at hearth temperatures lower than 450 °F, you may notice a buildup on the interior walls and/or ceiling of the oven. If this is the case, use the following procedure to periodically clean the oven. The frequency of thermal cleaning will be determined by the amount of buildup experienced. The amount and rate of buildup will largely be determined by the types of food cooked in the oven, and by how long the oven is operated at temperatures low enough to allow buildup to occur.

THERMAL CLEANING

Gas-fired Oven: If a Wood Stone gas-fired oven is operated at low temperatures (below 450 °F), it is possible that grease from food could condense on the walls and ceiling of the oven. To remove the grease that has accumulated on the walls and ceiling of the oven, simply turn the radiant flame to its highest setting. Monitor the floor temperature displayed on the Controller. When the floor reaches 600 °F, lower the flame slightly so as to maintain the oven floor temperature near 600 °F for about an hour. Once the oven dome appears clean, allow the oven to return to normal operating temperatures and continue normal operation.



PROBLEM	CAUSE/SOLUTION
Controller will not turn on	<ol style="list-style-type: none"> Incoming power to oven turned off. Check circuit breaker for circuit supplying the oven. Check that any wall switches external to the oven that control oven power are turned on. Check that any interlocks external to the oven are turned on. If Controller still does not turn on, please contact Wood Stone for assistance.
Radiant flame does not light	<ol style="list-style-type: none"> Is gas turned on to the oven? Is gas shut-off valve turned all the way on? Debris in burner. Burner may require cleaning. Contact Wood Stone for assistance. Damaged igniter or gas valve. Contact Wood Stone for assistance. If the oven is being started for the first time: Has all air been bled from the gas line? Is the switch on the SV-2 valve in the ON position? NOTE: Valve is located beneath the oven at the rear, towards the side where the radiant burner is located.
Underfloor burner is not running. “Hearth Heat” light is off.	Hearth temperature is above the Hearth Set Point.
Hearth Temperature is above the Hearth Set Point.	This is normal. Radiant (dome) flame can drive the temperature over the Hearth Set Point. The Hearth Set Point only controls the Underfloor IR burner. Turn down the dome flame if needed.
“Chec” display on Controller	Underfloor IR burner did not fire when the floor temperature dropped below the Hearth Set Point. Contact Wood Stone for assistance.
Flame cuts out	<ol style="list-style-type: none"> Debris in burner. Oven is being run with the Night Heat Retention Door in place. Door must be removed whenever the oven is turned on. Wind blowing into the oven, or other venting issue.

Please contact Wood Stone at 1-800-988-8103 should service be necessary, or if you have any questions about your oven. Our normal service hours are Mon.–Fri., 8am–5pm Pacific time. If calling after hours, follow the recorded instructions for emergency service and a Wood Stone technician will get back to you promptly.



WHAT TYPE OF WOOD SHOULD YOU USE TO FIRE YOUR SOLID FUEL COOKING EQUIPMENT?

The answer to this question depends on several considerations: geographical location, availability and relative cost of various fuelwood species and individual preferences regarding the flavor qualities of various wood types. There are a wide variety of good fuelwood species in all geographic locations. Each species of wood has different characteristics. The table below should help weigh the pros and cons of various types of wood. Wood from conifers (pine trees) is not recommended due to its poor fuelwood characteristics (low weight, low-med heat, poor coaling, high sparking and high residual creosote).

Wood Type	Heat	Lb/Cord	Lighting	Coaling	Sparks	Fragrance*
Alder	Med-Low	2500	Fair	Good	Moderate	Slight
Apple	High-Med	4400	Fair	Excellent	Few	Excellent
Ash	High	3500	Fairly Difficult	Good-Excellent	Few	Slight
Beech	High	3800	Difficult	Excellent	Few	Good
Birch (white)	Medium	3000	Easy	Good	Moderate	Slight
Cherry	Medium	2000	Fair	Excellent	Few	Excellent
Elm	High	2300	Very Difficult	Good	Very Few	Fair
Hickory	Very High	4200	Fairly Difficult	Excellent	Moderate	Excellent
Maple (red)	High-Med	3200	Fairly Difficult	Excellent	Few	Good
Maple (sugar)	High	3700	Difficult	Excellent	Few	Good
Mesquite	Very High		Very Difficult	Excellent	Many	Excellent
Oak (live)	Very High	4600	Very Difficult	Excellent	Few	Fair
Oak (red)	High	3700	Difficult	Excellent	Few	Fair
Oak (white)	Very High	4200	Fairly Difficult	Excellent	Few	Fair
Pecan	High		Fair	Good	Few	Good

*The desirability of various fragrances is largely a matter of personal preference.

Whichever type of wood you use, **MAKE SURE YOU KNOW THE MOISTURE CONTENT.** Properly seasoned wood contains 20% moisture or less. If wood contains more than 20% moisture, it should not be accepted for use. Wood should be stored off the ground and out of the rain in an environment that allows good air circulation so that the drying process can continue. Wet wood is the most common operational difficulty associated with wood-fired cooking equipment. Wood Stone's optional Mini-Ligno E Wood Moisture Meter can save you from paying for water when you thought you were paying for wood (see the Tools & Accessories section of woodstone-corp.com, contact your dealer or Wood Stone).

Calculate your approximate monthly, daily and hourly fuel-wood costs using the following formulas:

The cost of well-seasoned hardwood varies greatly with geographical location.

$$\text{Cost per month} = A \times C \quad \text{Cost per day} = \frac{A \times C}{30} \quad \text{Cost per hour} = \frac{A \times C}{\frac{30}{12 \text{ hr day}}}$$

A = Cost/cord (from wood supplier)

B = lb/cord (from above table)

C = Cords/mth (from experience, or call Wood Stone for an estimate)

When burned, a pound of any wood releases approximately 6500 BTU/hr, so it is better to compare the price of wood by the pound rather than by the cord. A full cord of wood measures 4' x 4' x 8' when stacked.

$$\text{Cost per lb} = \frac{A}{B}$$

Do not use pressed wood products in Wood Stone food service equipment, they may damage the ceramics.



OPTIONAL DECORATIVE FLAME BURNER

For Fire Deck ovens equipped with a Decorative Flame burner, the Decorative Flame turns on automatically when the oven Controller is turned on.

IMPORTANT: DO NOT USE THE DECORATIVE FLAME BURNER TO IGNITE WOOD OR SUPPORT THE WOOD FIRE. TAKE CARE NOT TO BRUSH DEBRIS INTO THE DECORATIVE FLAME BURNER WELL.

Do not use the burner well for dumping debris. Make every effort to keep ash and other debris out of the Decorative Flame burner well. Do not use the Decorative Flame burner as a “backstop” when shoveling ash and/or coals out of the oven. Using the oven floor brush and ash shovel, remove coals and ash through the oven doorway and dispose of safely. Use the brushes provided to remove debris from around the Radiant Burner wells. See electrical diagram below.

+ Decorative Flame

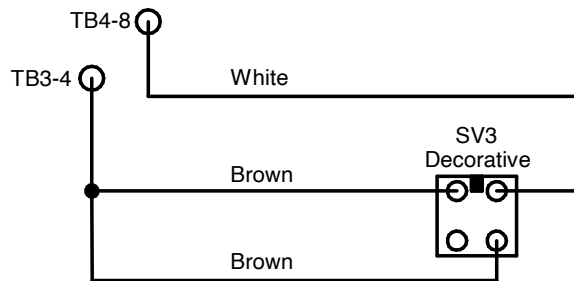

Bellingham, WA +1(360)650-1111 www.woodstone-corp.com

DIAG #: WD103 Rev. 1

DATE: 11/14/2023



FD-6045 120 VAC MODEL RFG-(L or R)-IR TYPE 2 CONTROLLER

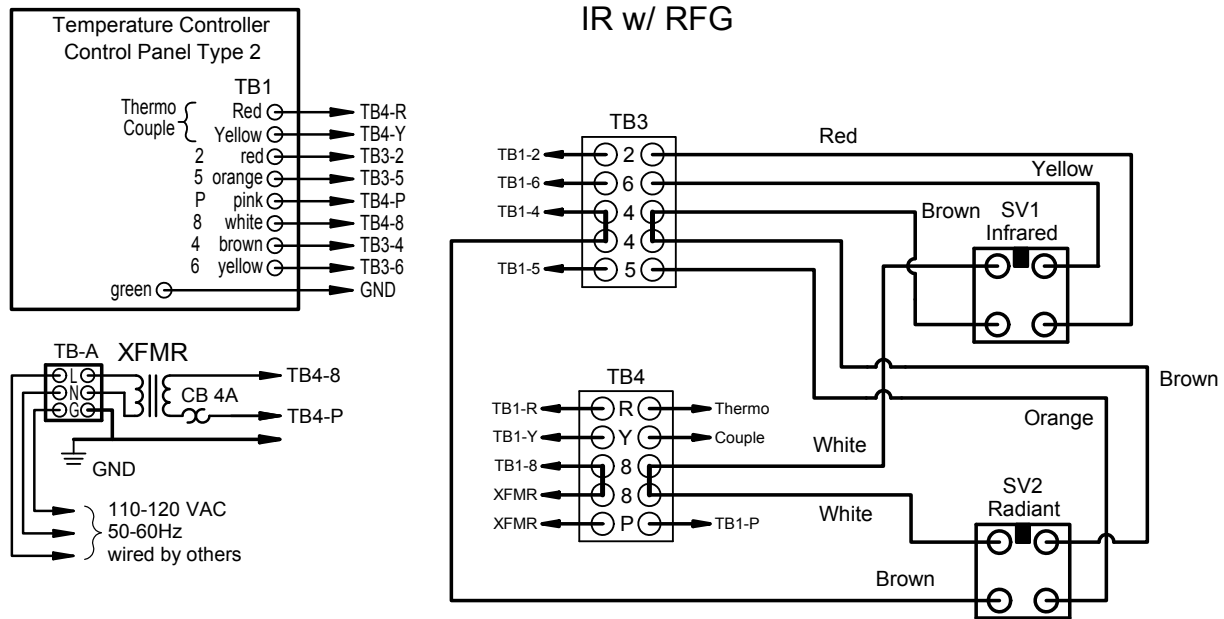

Bellingham, WA +1(360)650-1111 www.woodstone-corp.com

DIAG #: WD064 Rev. 0
DATE: 3/28/2014



**FD-6045 120 VAC MODEL
W-IR
TYPE 2 CONTROLLER**

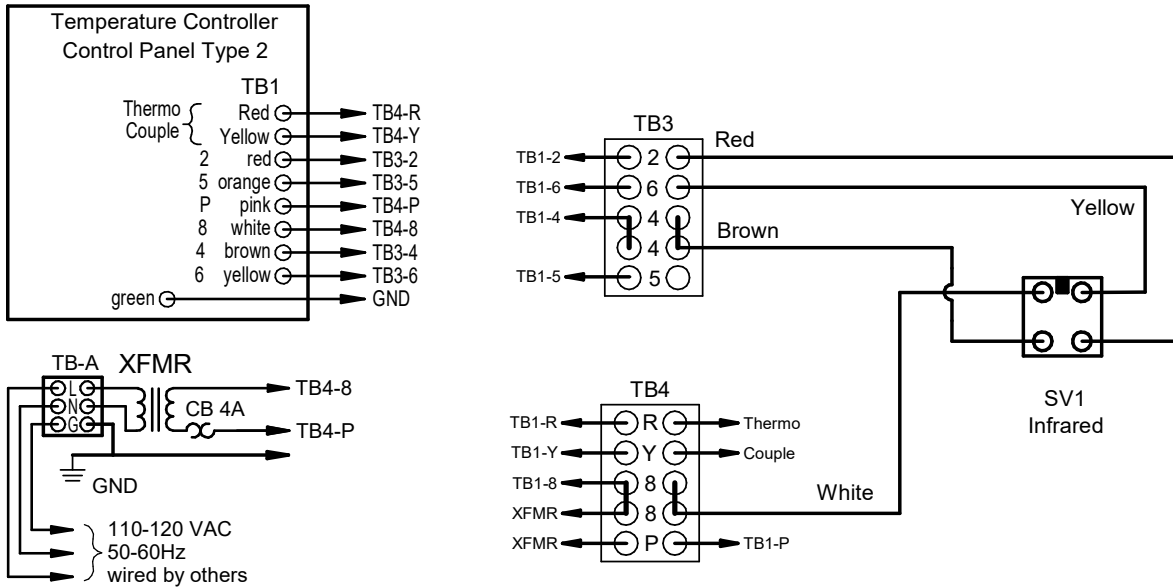

Bellingham, WA +1(360)650-1111 www.woodstone-corp.com

DIAG #: WD061 Rev. 0
DATE: 3/28/2014



**FD-6045 220-240 VAC MODEL
RFG-(L or R)-IR
TYPE 2 CONTROLLER**

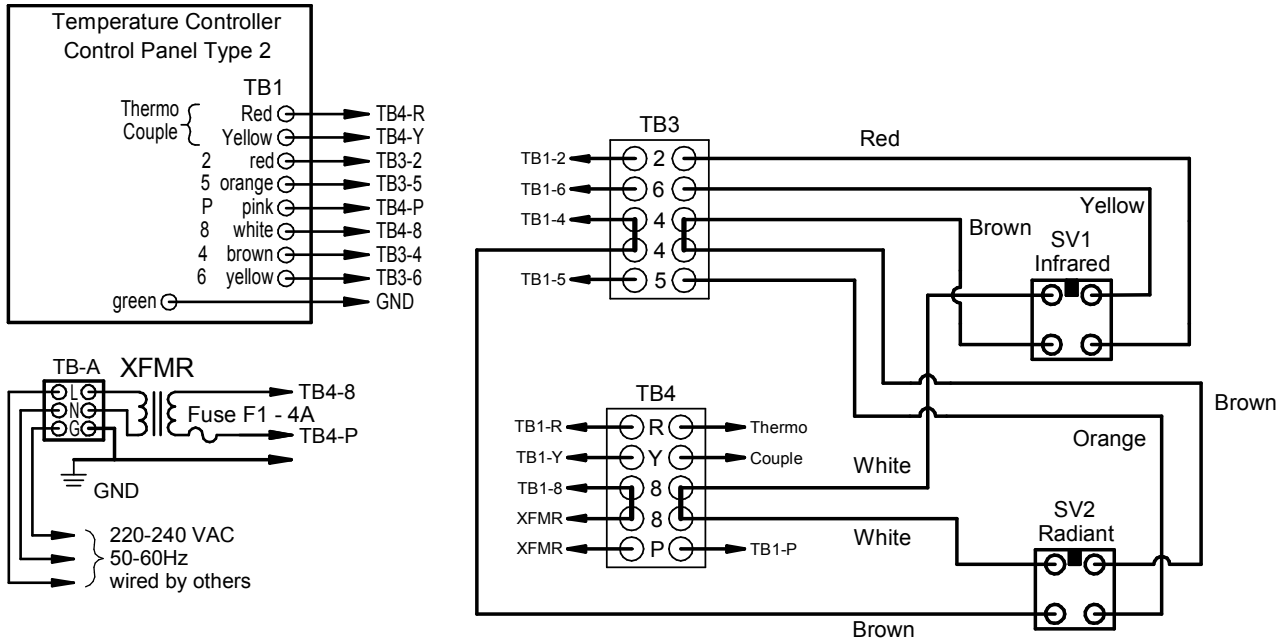

Bellingham, WA +1(360)650-1111 www.woodstone-corp.com

DIAG #: WD065 Rev. 1
DATE: 12/12/2018



INTERLOCK OF OVEN CONTROL TO AN EXHAUST FAN

This connection is intended to interrupt power to the oven until the fan is turned ON.

This connection is NOT to be used with ovens burning solid fuel.
The ventilation system must be running any time there is solid fuel burning in the oven.
Failure to follow this instruction can lead to a fire, as well as dangerous buildup of combustion byproducts, including Carbon Monoxide.

Wired by others

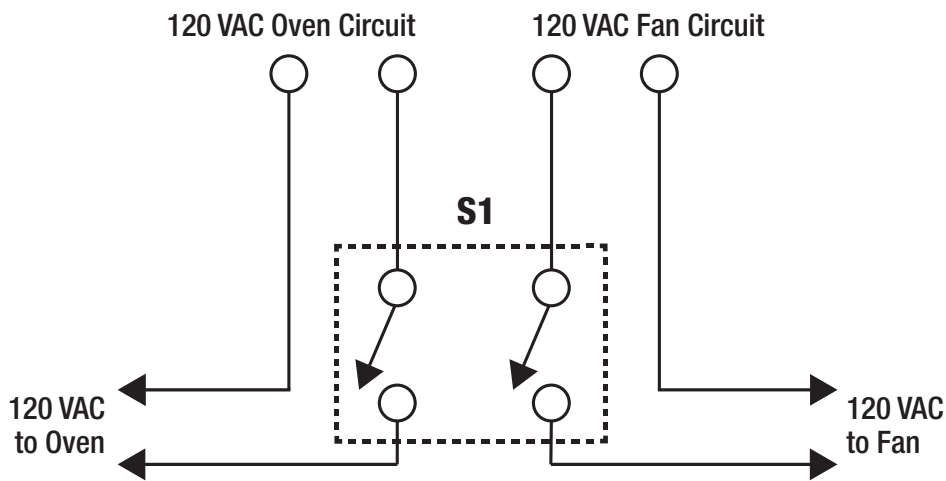

S1 is a Double Pole, Single Throw (DPST) switch provided by others.

S1 is a double pole, single throw switch (provided by others) that interrupts in-coming power to both the oven and the fan. The intent is to prevent the operation of the oven’s gas burner in the event the fan is shut off.

Any interruption of the power to the oven will cause the oven (including all burners and pilots) to shut off, and it will be necessary to restart the oven by pressing the start switch once power is restored.

For additional interlock options, see the Wood Stone Interlock Options supplement in the Manuals section on the website, woodstone-corp.com, or contact Wood Stone for additional information.

**ALL WARRANTY SERVICE MUST BE PRE-APPROVED BY WOOD STONE**

Wood Stone warrants its equipment to the original purchaser against defects in material or manufacture for a period of one year from the original date of purchase, subject to the following exclusions and limitations.

Please contact the factory first at 1.800.988.8103 or 1.360.650.1111, seven days a week. Our normal business hours are 8am to 5pm Pacific time Monday–Friday. If calling during non-business hours, follow the recorded instructions for emergency service and a Wood Stone technician will get back to you promptly.

EXCLUSIONS

The warranties provided by Wood Stone do not apply in the following instances:

1. In the event that the equipment is improperly installed. Proper installation is the responsibility of the installer; proper installation procedures are prescribed by the Wood Stone Installation and Operation Manual.
2. In the event the equipment is improperly or inadequately maintained. Proper maintenance is the responsibility of the user; proper maintenance procedures are prescribed in the Wood Stone Installation and Operation Manual. Burner problems resulting from debris or ash in the burner well will not be covered by the warranty. Call with questions regarding maintenance frequency.
3. In the event that the failure or malfunction of the appliance or any part thereof is caused by abnormal or improper use or is otherwise not attributable to defect in material or manufacture.
4. In the event that the appliance, by whatever cause, has been materially altered from the condition in which it left the factory.
5. In the event that the rating plate has been removed, altered or obliterated.
6. On parts that would be normally worn or replaced under normal conditions.
7. Normal cracking due to expansion and contraction stress relief in the ceramic firebox.
8. In wood-fired equipment configurations, in the event that pressed log products of any type have been burned in the equipment.
9. In coal-fired oven configurations, in the event any type of coal other than anthracite coal fuel has been used.
10. Damage resulting from the use of chemical cleaning products in the oven, as well as any damage from liquids or chemicals, including water, being poured or sprayed into the oven.

If any oral statements have been made regarding this appliance, such statements do not constitute warranties and are not part of the contract of sale. This Limited Warranty constitutes the complete, final and exclusive statement with regard to warranties.

THIS LIMITED WARRANTY IS EXCLUSIVE AND IN LIEU OF ALL OTHER WARRANTIES WHETHER WRITTEN, ORAL OR IMPLIED, INCLUDING, BUT NOT LIMITED TO, ANY WARRANTY OF MERCHANTABILITY OR FITNESS FOR PARTICULAR PURPOSE OR WARRANTY AGAINST LATENT DEFECTS.

LIMITATIONS OF LIABILITY

In the event of warranty claim or otherwise, the sole obligation of Wood Stone shall be the repair and/or replacement, at the option of Wood Stone, of the appliance or component or part thereof. Such repair or replacement shall be at the expense of Wood Stone with the exception of travel over 100 miles or two hours, overtime, and holiday charges which shall be at the expense of the purchaser. Any repair or replacement under this warranty does not constitute an extension of the original warranty for any period of the appliance or for any component or part thereof. Parts to be replaced under this warranty will be repaired or replaced at the option of Wood Stone with new or functionally operative parts. The liability of Wood Stone on any claim of any kind, including claims based on warranty, expressed or implied, contract, negligence, strict liability or any other theories shall be solely and exclusively the repair or replacement of the product as stated herein, and such liability shall not include, and purchaser specifically renounces any rights to recover, special, incidental, consequential or other damages of any kind whatsoever, including, but not limited to, injuries to persons or damage to property, loss of profits or anticipated profits, or loss of use of the product.

TO SECURE WARRANTY SERVICE

If you claim a defect covered by this Limited Warranty, contact:

Wood Stone Corporation, Attn: Service Department, 1801 W. Bakerview Rd., Bellingham, WA 98226 USA
Phone 1.800.988.8103 or 1.360.650.1111

WOOD STONE

WOOD STONE CORPORATION
1801 W. Bakerview Rd.
Bellingham, WA 98226 USA

Toll Free 800.988.8103
Tel 360.650.1111
Fax 360.650.1166

www.woodstone-corp.com

An ongoing program of product improvement may require us to change specifications without notice.