



WS-FD-11290-RFG-RR-IR configuration shown.

HEARTH CAPACITY

8" pizzas:	75	16" pizzas:	20
10" pizzas:	55	18" pizzas:	16
12" pizzas:	42	20" pizzas:	12

Assuming 5-minute cook times, the approximate maximum hourly production capacity can be calculated by multiplying the above numbers by 12. Cook times will also vary depending on "style" of pizza. **Note:** The addition of an optional decorative flame will decrease space and impact overall cooking capacity.

GUIDE TO MODEL NUMBERS

	Underfloor IR Burner	Left Side Radiant Flame	Right Side Radiant Flame	Decorative Flame (-DF)	Wood Required	Combination	Natural Gas	Liquid Propane
WS-FD-11290-RFG-LL-IR	X	2		-DF			-NG	-LP
WS-FD-11290-RFG-LL-IR-W	X	2			X		-NG	-LP
WS-FD-11290-RFG-RR-IR	X		2	-DF			-NG	-LP
WS-FD-11290-RFG-RR-IR-W	X		2		X		-NG	-LP
WS-FD-11290-W-IR	X				X		-NG	-LP

Additional configurations are available. Please contact the factory.

Job Name	
Model	WS-FD-11290
Item#	

The Fire Deck 11290 oven features a door opening 60 inches wide x 10 inches high with a stainless steel mantle at the hearth. The cooking area is 90 inches wide x 78 inches deep, resulting in a 48-square-foot cooking surface. A tensioned steel exoskeleton surrounding the hearth and dome perimeter ensures structural integrity and longevity. Wrapped in spun ceramic fiber insulation and requiring only a 1-inch side clearance to combustibles, the monolithic cast-ceramic 6-inch thick hearth and monolithic 4-inch thick dome rest on a black painted steel stand. The oven body front, top, back and sides are finished with galvanized steel. The oven arrives completely assembled, ETL Listed, ready to install and is made in the USA. A set of casters ship on the oven to assist with installation (remove once installed). Information about custom finishes, tools and accessories can be found online at: woodstone-corp.com.

FUEL CONFIGURATIONS

GAS-FIRED ONLY: Configured to burn either natural gas (NG) or liquid propane (LP).*

☐ RADIANT FLAME + UNDERFLOOR IR (RFG-IR):

Heated by an adjustable radiant flame located on both sides of the cooking chamber, along with a thermostatically controlled infrared burner which is mounted under the oven deck to ensure high production capacity.

☐ DECORATIVE FLAME (-DF): Provides an additional 15,000 BTU/hr flame at rear of cooking chamber for show.

☐ WOOD WITH GAS ASSIST (W-IR): This wood-fired model is assisted by the additional BTUs of an Underfloor IR burner. **Note:** A wood fire is required with this configuration.

☐ COMBINATION (-W): Allows optional wood burning for ovens with gas burner configurations.* **Note:** Adding wood to an oven with an RFG burner will reduce available hearth capacity.

☐ COAL-FIRED (-CL): See Coal-Fired Oven (11290) 

*Gas type must be specified at time of order.



t. 360.650.1111
tf. 800.988.8103
f. 360.650.1166

Wood Stone Corporation
1801 W. Bakerview Rd.
Bellingham, WA 98226 USA
info@woodstone-corp.com
woodstone-corp.com

REVISED: WINTER 2024

An ongoing program of product improvement may require us to change specifications without notice.



FIRE DECK 11290

STONE HEARTH OVEN • WS-FD-11290

VERY IMPORTANT!!

Oven is shipped with casters. Height with casters to the top of the flue collar is 87-3/4". Once the oven is in place the casters must be removed. Utility connections are made from underneath the oven. This view is showing a right-hand burner configuration. A left-hand burner configuration would mirror this location.

PLAN VIEW

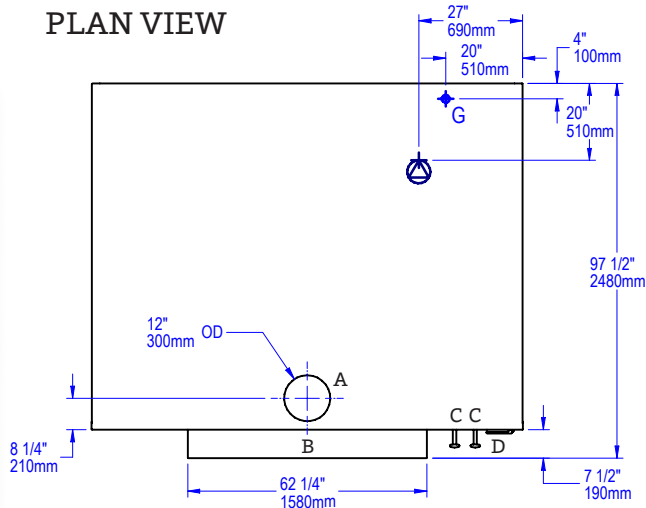

FRONT VIEW

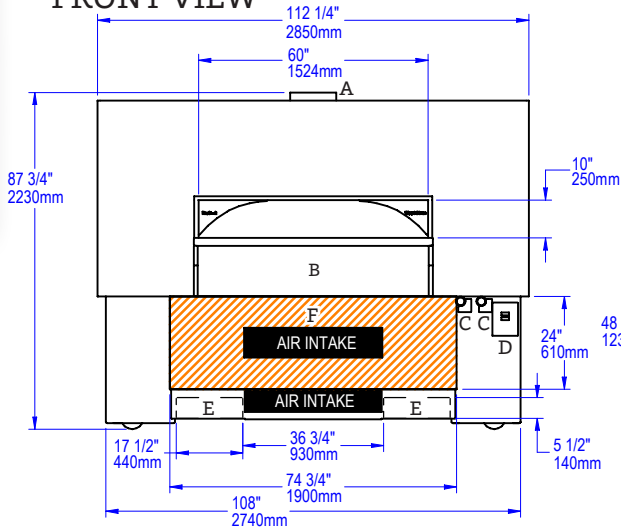

SIDE VIEW

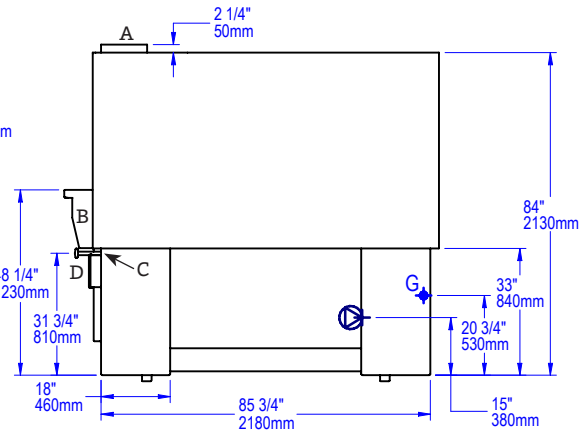

A	Flue Collar
B	Mantle
C	Flame Height Control Knob
D	Digital Controller
E	Forklift Here
	Electrical Connection
F	Service Panel or Optional Storage Box
	Gas Connection
	Must Be Left Removable for Service
	AIR INTAKE: Do Not Facade or Cover Over

UTILITIES SPECIFICATIONS

GAS

Gas-Fired Only and Combination
1 inch gas inlet (FNPT)

Example models with two radiant burners and one IR burner

347,000 BTU/hr - Natural Gas (NG)

369,000 BTU/hr - Propane (LP)

BTU/hr Output Per Burner

	123,000 NG	135,000 LP
Radiant Flame Burner	123,000 NG	135,000 LP
IR Burner	100,000 NG	100,000 LP
Decorative Flame Adds	15,000 NG	15,000 LP

ELECTRICAL

Gas-Fired Only and Combination
120 VAC, 2 A, 50/60 Hz

Connection is made underneath the oven.

IMPORTANT: Models with -W or -CL in the model number must be vented as a solid fuel appliance.

VENTING INFORMATION

The Fire Deck 11290 can be direct connected to a power-ventilated, grease-rated chimney or be vented using a Listed Type 1 exhaust hood, or a hood constructed and installed in accordance with NFPA 96 and all relevant local and national codes. The oven must be vented in accordance with all relevant local and national codes, and in a manner acceptable to the authority having jurisdiction.

Ship Weight: 11,500 lbs / 5,216 kg



t. 360.650.1111
tf. 800.988.8103
f. 360.650.1166

Wood Stone Corporation
1801 W. Bakerview Rd.
Bellingham, WA 98226 USA
info@woodstone-corp.com
woodstone-corp.com

REVISED: WINTER 2024

An ongoing program of product improvement may require us to change specifications without notice.

