

Installation and Operation Manual



MT. ST. HELENS

Charboilers

*Solid Fuel Charbroilers,
Optional Countertop Models*

MT. ST. HELENS (36 SERIES)

WS-SFB-(34, 45, 57, 72)

MT. ST. HELENS (26 SERIES) WS-SFB-5426



WOOD STONE CORPORATION

1801 W. Bakerview Rd.
Bellingham, WA 98226 USA

Toll Free 800.988.8103

Tel 360.650.1111

Fax 360.650.1166

www.woodstone-corp.com

DOC NO **M0059.06** REVISED **MARCH 2016**



TABLE OF CONTENTS

Mt. St. Helens **3**
Cautions & Warnings **4**
Specifications (34, 45, 57, 72) **6**
Specifications (5426) **7**
Clearances & Venting **8**
Installation **9**
Broiler Shelf Installation **10**
Fuel Safety **11**
Fueling the Charbroiler **12**
Cleaning **14**
Fuelwood Facts **15**
Replacement Parts **16**
Limited Warranty **17**

**INSTALLATION AND OPERATION MANUAL FOR THE
WOOD STONE MT. ST. HELENS CHARBROILER**

**STONE-FIRED COOKING EQUIPMENT
SOLID FUEL CHARBROILER
WS-SFB-(34, 45, 57, 72) AND WS-SFB-5426
INCLUDING COUNTERTOP MODELS**

ADDITIONAL MANUAL COPIES AVAILABLE UPON REQUEST



Shown: SFB-57 with optional Stainless
Steel Shelf and Sauce Pan Racks.



INSTALLATION AND OPERATING INSTRUCTIONS FOR THE WOOD STONE MODEL WS-SFB MT. ST. HELENS CHARBROILER INCLUDING COUNTERTOP MODELS

RETAIN THIS MANUAL FOR FUTURE REFERENCE

Additional copies of this manual at woodstone-corp.com.

For prompt responses to service/maintenance questions, call us at @ 1-800-988-8103.

READ ALL INSTRUCTIONS BEFORE INSTALLING AND USING THIS APPLIANCE

Please read this entire manual before you install the oven. Failure to follow instructions may result in property damage, bodily injury or even death. Contact your local building or fire officials about restrictions and installation inspection in your area.

WHEN THIS OVEN IS NOT PROPERLY INSTALLED, A FIRE MAY RESULT. TO REDUCE THE RISK OF FIRE, FOLLOW THE INSTALLATION INSTRUCTIONS. IT IS RECOMMENDED THAT THIS OVEN BE INSTALLED, MAINTAINED AND SERVICED BY AUTHORIZED PROFESSIONALS.

WARNING: Improper installation, adjustment, alteration, service or maintenance can result in property damage, injury or death. Read the installation, operation and maintenance instructions thoroughly before installing or servicing this equipment.

AVERTISSEMENT: L'installation, le réglage, la modification, la réparation ou l'entretien incorrect de cet appareil peut causer des dommages matériels, de blessures ou la mort. Lire attentivement les instructions d'installation, de fonctionnement et d'entretien avant de procéder à son installation ou entretien.

FOR YOUR SAFETY: Do not store or use gasoline or other flammable vapors or liquids in the vicinity of this or any other appliance.

POUR VOTRE SÉCURITÉ: Ne pas entreposer ni utiliser d'essence ou d'autres vapeurs de liquides inflammables ou des liquides dans les environs de ce ou de tout autre appareil.

CAUTION: Never use gasoline, gasoline-type lantern fuel, kerosene, charcoal lighter fluid or similar liquids to start or freshen up a fire in this oven. Keep all such liquids well away from this oven when in use. **DO NOT USE PRODUCTS NOT SPECIFIED FOR USE WITH THIS APPLIANCE. USE SOLID WOOD FUEL ONLY.**



A MAJOR CAUSE OF OVEN RELATED FIRES IS A FAILURE TO MAINTAIN REQUIRED CLEARANCES TO COMBUSTIBLE MATERIAL. IT IS OF UTMOST IMPORTANCE THAT THIS OVEN BE INSTALLED ONLY IN ACCORDANCE WITH THESE INSTRUCTIONS.

CAUTIONS:

- (i) DO NOT INSTALL IN A MOBILE HOME.
- (ii) DO NOT CONNECT TO USE IN CONJUNCTION WITH ANY AIR DISTRIBUTION DUCTWORK UNLESS SPECIFICALLY APPROVED FOR SUCH INSTALLATIONS.
- (iii) DO NOT USE CHEMICALS OR FLUIDS TO START THE FIRE
- (iv) DO NOT BURN GARBAGE OR FLAMMABLE FLUIDS SUCH AS GASOLINE, NAPHTHA OR ENGINE OIL.
- (v) HOT WHILE IN OPERATION. KEEP CHILDREN, CLOTHING AND FURNITURE AWAY. CONTACT MAY CAUSE SKIN BURNS.

Always keep the area under and around this appliance free and clear of any and all combustible materials. Wood fuel should be stored in accordance with the Standard for Ventilation Control of Fire Protection of Commercial Cooking Operations, NFPA 96, and local authorities having jurisdiction.

SAVE THE INSTRUCTIONS

Wood Stone Mt. St. Helens Solid Fuel Charbroiler has been tested and approved by Intertek Testing Services and ETL Listed to ANSI/UL 1482, UL Subject 2162, ULC-S627-00 and ANSI/NSF Standard 4.



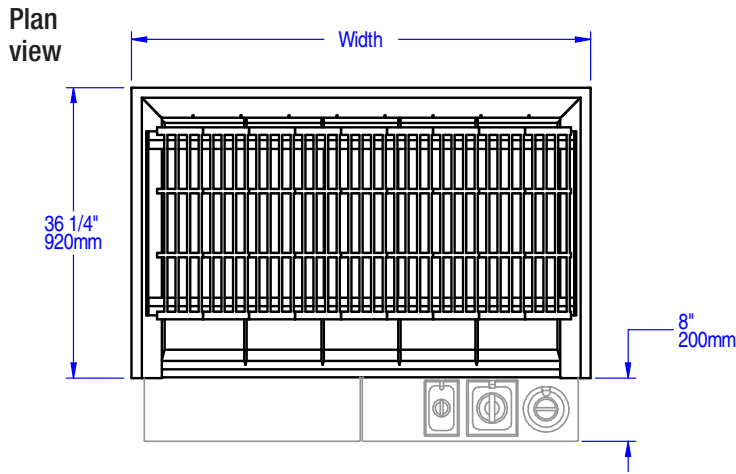

Shown with optional Skewer (Satay) Rack, Sauce Pan Rack and Stainless Steel Shelves.

Model	Width	6x24" Grates	4x24" Grates	Shipping Wgt (lbs)
SFB-34	34" (860mm)	5		1,100
SFB-45	45" (1140mm)	7		1,300
SFB-57	57" (1450mm)	9		1,600
SFB-72	72" (1830mm)	10	2	1,800
SFB-34-CT	34" (860mm)	5		900
SFB-45-CT	45" (1140mm)	7		1,150
SFB-57-CT	57" (1450mm)	9		1,300
SFB-72-CT	72" (1830mm)	10	2	1,350

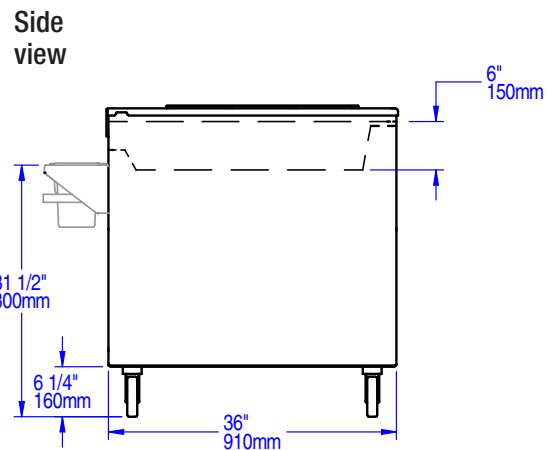
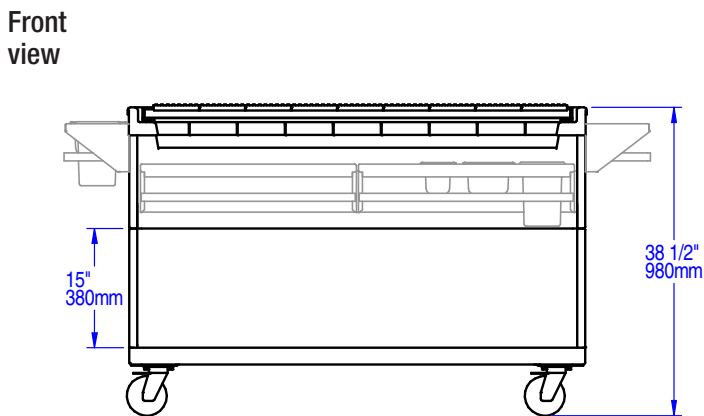
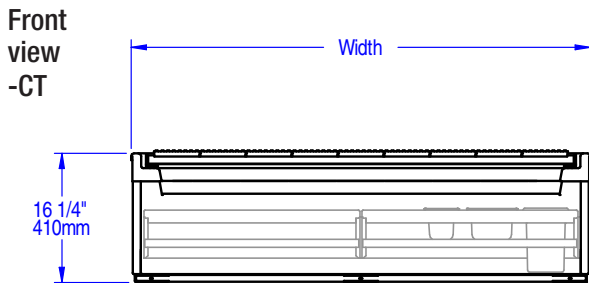

Venting: The Mt. St. Helens must be vented with a Listed Type 1 exhaust hood, or one constructed in accordance with NFPA 96 and all relevant local and national codes. The charbroiler must be vented as a solid fuel appliance in accordance with all relevant local and national codes, and in a manner acceptable to the authority have jurisdiction.



Plan view

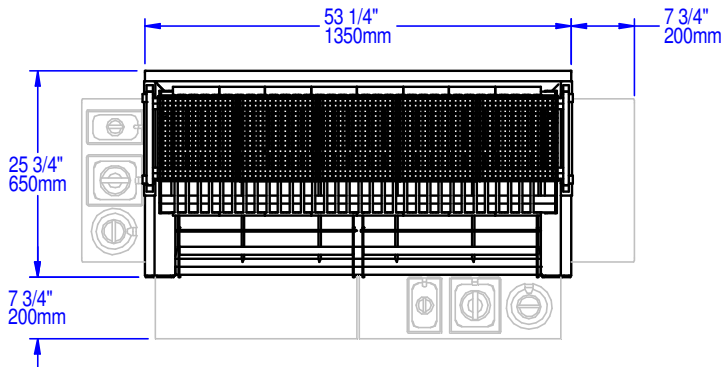

Shown with optional Broiler Shelf, Skewer (Satay) Rack, Sauce Pan Racks and Stainless Steel Shelf.

Model	Width	6x16\" Grates	Shipping Wgt (lbs)
SFB-5426	54\" (1372mm)	8	1,100
SFB-5426-CT	54\" (1372mm)	8	900

Front view -CT

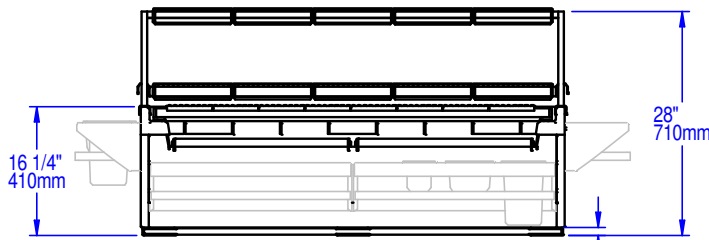

Front view

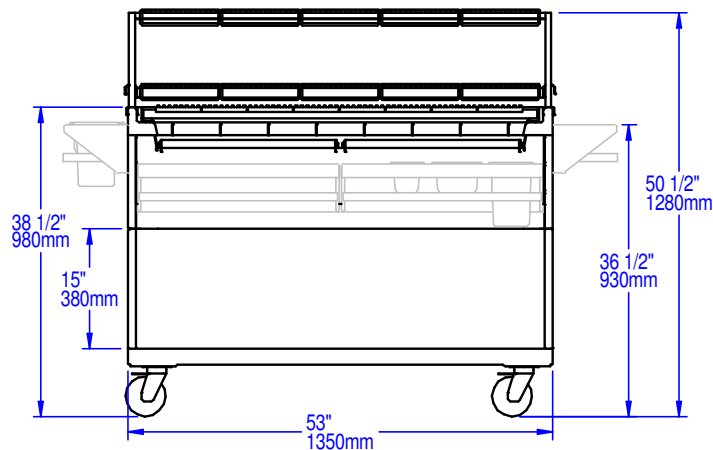

Side view

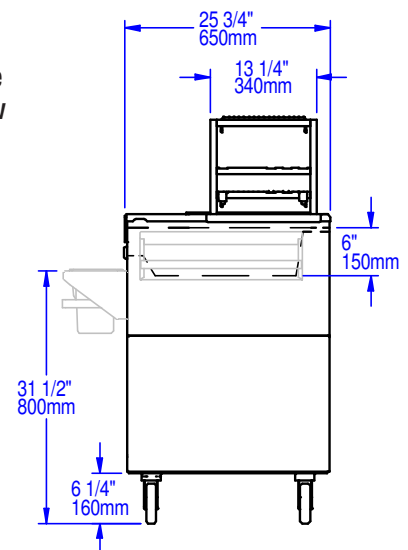

Venting: The Mt. St. Helens must be vented with a Listed Type 1 exhaust hood, or one constructed in accordance with NFPA 96 and all relevant local and national codes. The charbroiler must be vented as a solid fuel appliance in accordance with all relevant local and national codes, and in a manner acceptable to the authority have jurisdiction.



INSTALLATION CLEARANCES

Note: Unit must be installed beneath a Type 1 exhaust hood in accordance with NFPA 96. See Venting section below

Floor: For use on only on noncombustible floors (installér sur un plancher incombustible seulement). The Mt. St. Helens must be installed on a non-combustible floor extending 3 ft. in all directions from the appliance or one provided with a non-combustible covering acceptable to the authority having jurisdiction.

A MAJOR CAUSE OF OVEN RELATED FIRES IS A FAILURE TO MAINTAIN REQUIRED CLEARANCES TO COMBUSTIBLE MATERIAL. IT IS OF UTMOST IMPORTANCE THAT THIS OVEN BE INSTALLED ONLY IN ACCORDANCE WITH THESE INSTRUCTIONS.

MINIMUM CLEARANCES TO COMBUSTIBLE CONSTRUCTION	SIDES, FRONT & BACK: 36" ABOVE: 72"
CLEARANCES TO NON-COMBUSTIBLE CONSTRUCTION*	0"

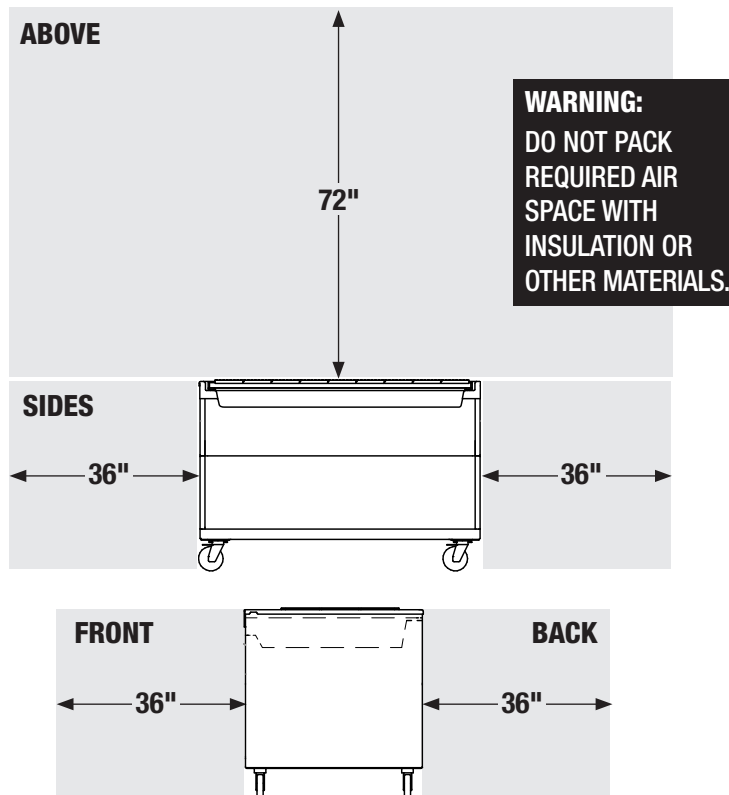
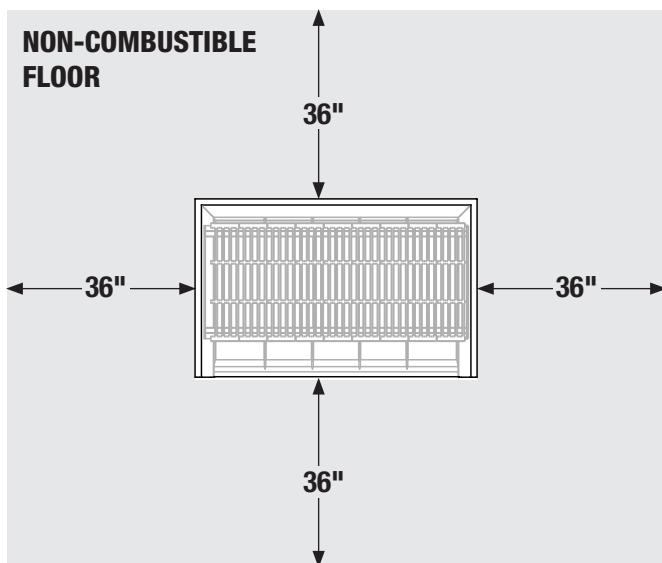

*Examples of non-combustible construction include: metal stud wall faced with cement board with a tile or metal finish; cement block with tile or metal finish.

VENTING

The Mt. St. Helens must be vented using a Listed Type 1 exhaust hood, or one constructed in accordance with NFPA 96 and all relevant local and national codes. The charbroiler must be vented as a solid fuel appliance, in accordance with all relevant local and national codes, and in a manner acceptable to the authority having jurisdiction.

As with all solid fuel cooking equipment and exhaust systems, **a regular inspection and cleaning schedule is needed to prevent the possibility of fire.** The frequency of inspection and cleaning will depend on hours of use and type and quality of fuelwood. Typically solid fuel installations will require cleaning and inspection at least monthly.

A fire protection system is required for safe installation of this piece of equipment. Refer to national and local codes for solid fuel cooking equipment.



UNLOADING THE MT. ST. HELENS

Under no circumstances should manual unloading be attempted. If a receiving dock is available, a pallet jack should be sufficient to remove the crated unit from the delivery truck. The use of a forklift (2,000 lb.) is suggested when moving the unit from the delivery truck to ground level.

SACRIFICIAL HEAT SHIELD (ALL MODELS)

Install at rear of firebox. Note SFB-72 has two shields, one on each side of the center divider.

FLASHING (COUNTERTOP MODELS ONLY)

Follow instructions below.

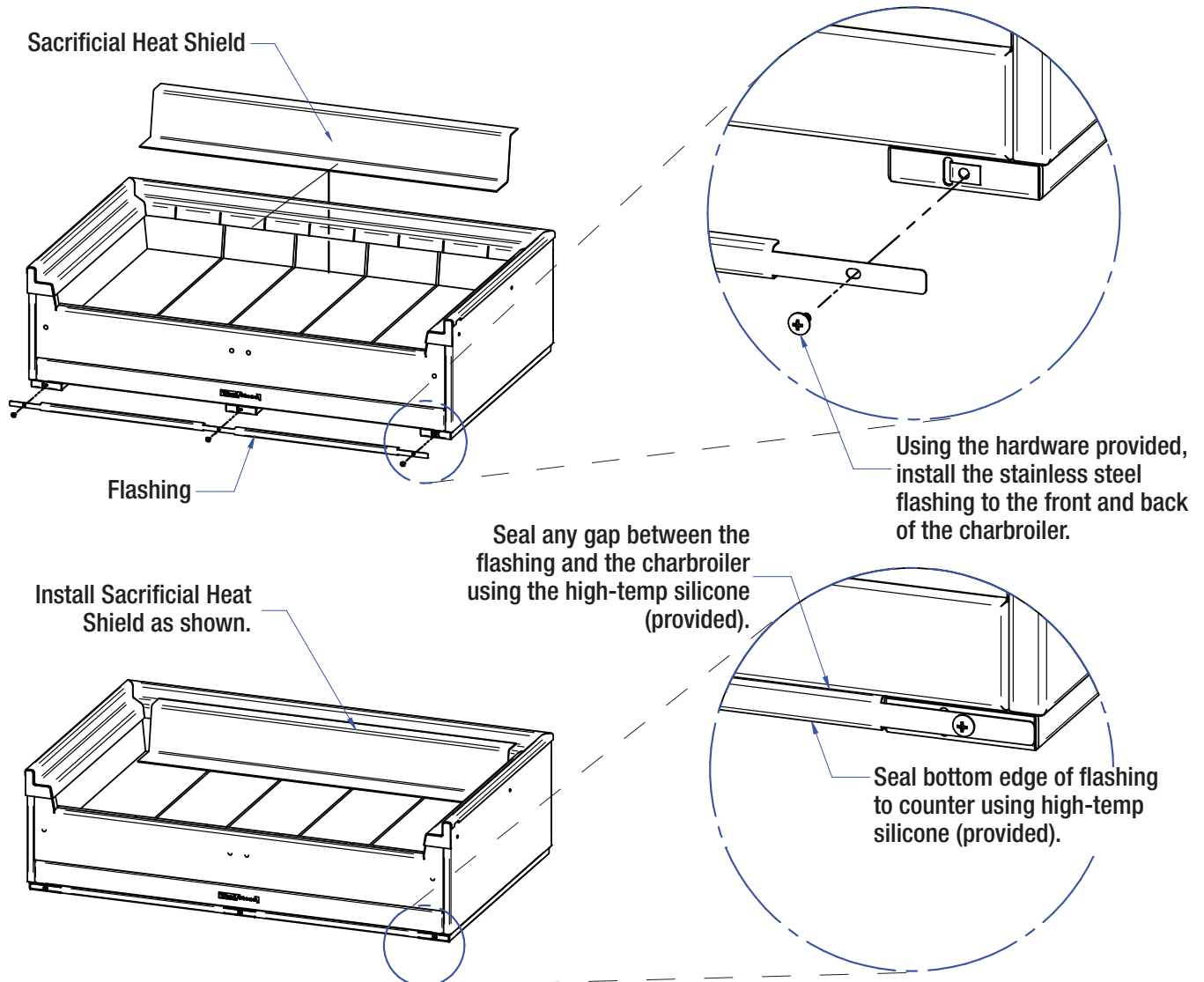



PLACE BROILER SHELF STAND ONTO CHARBROILER

1. The optional Broiler Shelf Stand is lowered onto the Mt. St. Helens so that the legs slide over the side walls. The shelf can be fastened in place to the charbroiler, if desired, using the supplied self-tapping stainless steel screws.

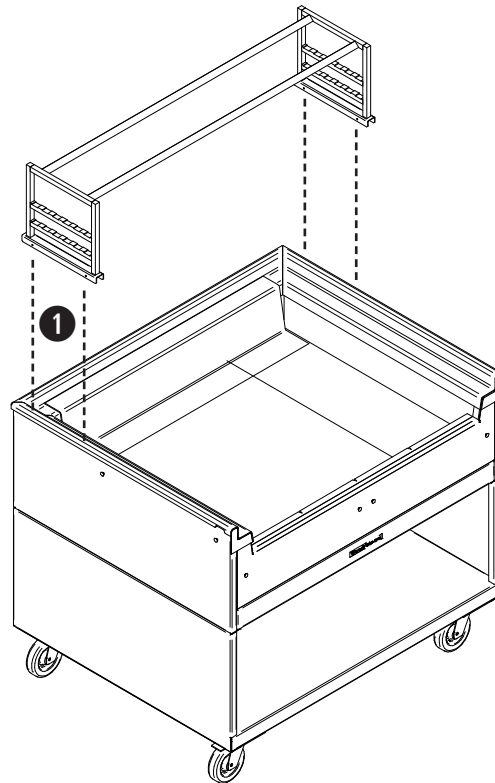

INSTALL RACKS ONTO STAND

2. Place the Wire Cooking Rack Supports onto the upper or lower bottom supports.
3. Place the lower Wire Cooking Racks onto the bottom supports.
4. Place the upper Wire Cooking Racks onto the top supports.

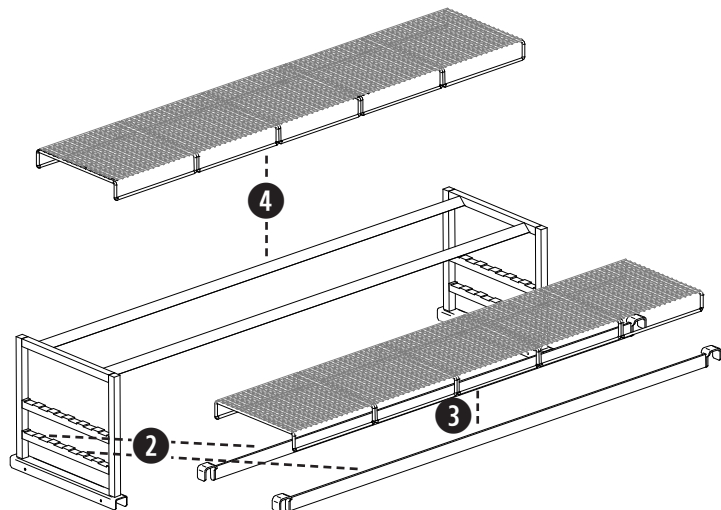



WOOD

Use only well seasoned hardwood to fuel the charbroiler. The wood should have a moisture content of less than 20%. For best results, pieces should be split so that the diameter does not exceed 5 inches. See Wood Stone's FUELWOOD FACTS section at the end of this manual.

CAUTION: NEVER USE GASOLINE, GASOLINE-TYPE LANTERN FUEL, KEROSENE, CHARCOAL LIGHTER FLUID OR SIMILAR LIQUIDS TO START OR FRESHEN-UP A FIRE IN THIS OVEN. KEEP ALL SUCH LIQUIDS WELL AWAY FROM THE OVEN WHEN IN USE.

WOOD STORAGE

Wood should be stored and handled in accordance with the recommendations outlined in NFPA 96.

DISPOSAL OF ASHES

Ashes should be placed in a metal container with a tight-fitting lid. The closed container of ashes should be placed on a non-combustible floor or on the ground, well away from the combustible materials, pending final disposal. When the ashes are disposed by burial in soil or otherwise locally dispersed, they should be retained in the closed container until all cinders have thoroughly cooled.

The optional Wood Stone's Dual Compartment Ash Dolly is available through your dealer. The specification sheet may be viewed on the Wood Stone website under Tools & Accessories.



Wood Stone's optional Double Compartment Ash Dolly. View the spec sheet at woodstone-corp.com in the Tools and Accessories section.



It is necessary to develop a consistent and simple fuel, fire and temperature management plan for cooking on your wood-fired charbroiler. This plan should be based on the most appropriate grill temperatures for your products. We have outlined the basic steps below to begin operating your charbroiler.

TO BEGIN



1. Pull the grate rack forward, and remove the center grill grates by using the Grate Tool. Stack grates on the remaining side grates until the fire has been established to keep the grates out of the intense start up fire heat, and to create working space.



2. Using the Ash Shovel, remove about 2/3rds of the fly ash. Move ash and any live coals along the back-center of the fire box. The coals and ash will help start the new fire faster.



LUMP CHARCOAL ONLY FIRE

3. Stack recommended quantity of charcoal (see table above) on top of any live coals and ash toward the back of the firebox. Ignite a fire starter and place it under the charcoal. After 1 hour, add charcoal as necessary to maintain the coal bed depth.

LUMP CHARCOAL AND WOOD FIRE

4. Stack 3 or 4 small pieces of wood in a conical tepee shape on top of any live coals towards the back of the fire box. Ignite a fire starter and place it under the wood.



5. As the wood fire gets going, add lump charcoal in front of the fire—do not extinguish the flame. The lump charcoal will help to quickly establish a good working coal bed.

Note: Without an optional rotisserie, the wood is primarily for theater, and will not be the primary source of live coals.



Lump charcoal quantities to fill charbroiler firebox

Model	Lump Charcoal (lbs)
SFB-34	10–15
SFB-45	15–20
SFB-5426	15–20
SFB-57	20–25
SFB-72	25–30

The well maintained firebox (side view)

The coal bed should be about 3" deep in the back and 1-1/2" in the front. A 5–10" open flame (as measured from the top of coal bed) will maintain this coal depth, producing the temperature regions shown below.

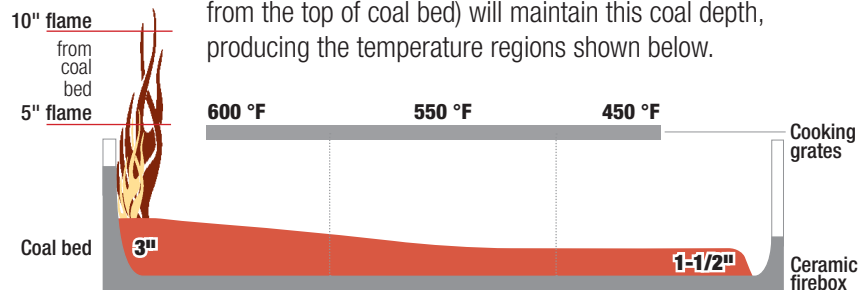



6. Once the fire is well established use the Grate Tool to distribute the coals in the firebox, with about 3" deep in the back, tapering to 1-1/2" deep in the front.

MAINTAINING THE FIREBOX



7. Place two medium pieces of wood on either side of the center flame every 20–30 minutes. The height of the open flame, 5–10 inches as measured from the top of the coal bed, controls the amount of live coals generated, and by extension, the temperature.

As necessary, add charcoal to maintain coal bed level, remembering it takes about 15–30 minutes for charcoal to ignite and significantly contribute to the coal bed. Proper firebox maintenance requires taking this delay into account to optimize temperature consistency and minimize over firing.



8. To optimize heat and energy, pull live coals forward out of the fire. Do not pull wood with open flame forward. Cooking over an open flame tends to burn fat, making food taste bitter.

See Fuel Tips below, and the FUELWOOD FACTS section at the end of this manual, for more information about fuel characteristics.

FUEL TIPS

LUMP CHARCOAL

Lump charcoal (we recommend Mesquite lump charcoal) is a carefully produced carbonized product that burns at a higher temperature for a longer period of time than live coals resulting from a natural wood fire. Using lump charcoal as the main source of heat simplifies grill temperature management and is often the only fuel used when kitchen theater isn't a consideration.

WOOD QUALITY

Wood that is not properly dried and sized is the most common operational problem with solid fuel cooking equipment.

The best woods for cooking are heavy hardwoods (Oak, Apple, Hickory, Pecan and Mesquite), with an average length of 16–18", and diameter of 3–5" (either full logs or the sides of split wood). Hardwoods are preferred because they produce more BTU/hr and they coal better, requiring less labor to maintain the same amount of heat.

Ideal moisture levels fall between 15–20%. Accurate moisture readings are taken from the **center** of a freshly split piece of wood. Wood should be kept in a covered area, but not totally enclosed (follow the recommendations in NFPA 96 for safe wood storage and handling practices).

Note: Wood at higher moisture levels produces more creosote residue, which accumulates on the flue lining and exhaust hood, increasing the risk of fire.

BUYING WOOD

Because most wood is sold for heating, it is often only cured for 4–8 months, rather than the 12–16 months required for cooking. It is important to make certain the wood you buy has been cured for cooking. Indicators of high moisture content include hissing (20–25% moisture level), or bubbles forming out the end (moisture higher than 25%). Wood Stone offers an optional Mini-Ligno E Wood Moisture Meter (see the Tools & Accessories section of woodstone-corp.com).



CHARBROILER CABINET

All exposed stainless surfaces of the unit should be wiped down as necessary (or daily) using an approved mild cleaning solution. Stubborn residues may be removed using a non-metallic scouring pad. When scouring stainless steel, scrub with the grain of the metal to avoid scratching the finish.

CHARBROILER GRILL

Scrub the cast iron grill grates (as necessary) with a wire brush to remove cooked on build-up. The stainless grill support rack can be removed and cleaned using hot water and an approved mild detergent.

CERAMIC FIREBOX

Remove excess ash from the firebox using the stainless shovel provided. **NEVER POUR WATER INTO THE CERAMIC FIREBOX.**

CREOSOTE: FORMATION AND NEED FOR REMOVAL

Creosote should be removed to reduce risk of fire. When wood is burned slowly, it produces tar and other organic vapors that combine with expelled moisture to form creosote. The creosote vapors condense in a relatively cool oven flue and exhaust hood of a slow burning fire. As a result, creosote residue accumulates on the flue lining and exhaust hood. When ignited, the creosote makes an extremely hot fire. The oven flue should be inspected twice monthly to determine when creosote build up has occurred. When creosote has accumulated, it should be removed to reduce risk of fire.



WHAT TYPE OF WOOD SHOULD YOU USE TO FIRE YOUR SOLID FUEL COOKING EQUIPMENT?

The answer to this question depends on several considerations: geographical location, availability and relative cost of various fuelwood species and individual preferences regarding the flavor qualities of various wood types. There are a wide variety of good fuelwood species in all geographic locations. Each species of wood has different characteristics. The table below should help weigh the pros and cons of various types of wood. Wood from conifers (pine trees) is not recommended due to its poor fuelwood characteristics (low weight, low-med heat, poor coaling, high sparking and high residual creosote).

Wood Type	Heat	Lb/Cord	Lighting	Coaling	Sparks	Fragrance*
Alder	Med-Low	2500	Fair	Good	Moderate	Slight
Apple	High-Med	4400	Fair	Excellent	Few	Excellent
Ash	High	3500	Fairly Difficult	Good-Excellent	Few	Slight
Beech	High	3800	Difficult	Excellent	Few	Good
Birch (white)	Medium	3000	Easy	Good	Moderate	Slight
Cherry	Medium	2000	Fair	Excellent	Few	Excellent
Elm	High	2300	Very Difficult	Good	Very Few	Fair
Hickory	Very High	4200	Fairly Difficult	Excellent	Moderate	Excellent
Maple (red)	High-Med	3200	Fairly Difficult	Excellent	Few	Good
Maple (sugar)	High	3700	Difficult	Excellent	Few	Good
Mesquite	Very High		Very Difficult	Excellent	Many	Excellent
Oak (live)	Very High	4600	Very Difficult	Excellent	Few	Fair
Oak (red)	High	3700	Difficult	Excellent	Few	Fair
Oak (white)	Very High	4200	Fairly Difficult	Excellent	Few	Fair
Pecan	High		Fair	Good	Few	Good

*The desirability of various fragrances is largely a matter of personal preference.

Whichever type of wood you use, **MAKE SURE YOU KNOW THE MOISTURE CONTENT.** Properly seasoned wood contains 20% moisture or less. If wood contains more than 20% moisture, it should not be accepted for use. Wood should be stored off the ground and out of the rain in an environment that allows good air circulation so that the drying process can continue. Wet wood is the most common operational difficulty associated with wood-fired cooking equipment. Wood Stone's optional Mini-Ligno E Wood Moisture Meter can save you from paying for water when you thought you were paying for wood (see the Tools & Accessories section of woodstone-corp.com).

Calculate your approximate monthly, daily and hourly fuel-wood costs using the following formulas:
The cost of well-seasoned hardwood varies greatly with geographical location.

$$\text{Cost per month} = A \times C \quad \text{Cost per day} = \frac{A \times C}{30} \quad \text{Cost per hour} = \frac{A \times C}{\frac{30}{12 \text{ hr day}}}$$

A = Cost/cord (from wood supplier)

B = lb/cord (from above table)

C = Cords/mth (from experience, or call Wood Stone for an estimate)

When burned, a pound of any wood releases approximately 6500 BTU/hr, so it is better to compare the price of wood by the pound rather than by the cord. A full cord of wood measures 4' x 4' x 8' when stacked.

$$\text{Cost per lb} = \frac{A}{B}$$

Do not use pressed wood products in Wood Stone food service equipment, they may damage the ceramics.



The drawing below indicates part numbers for the replaceable parts on all Mt. St. Helens models. See table for specific model grate capacities and grate part numbers.

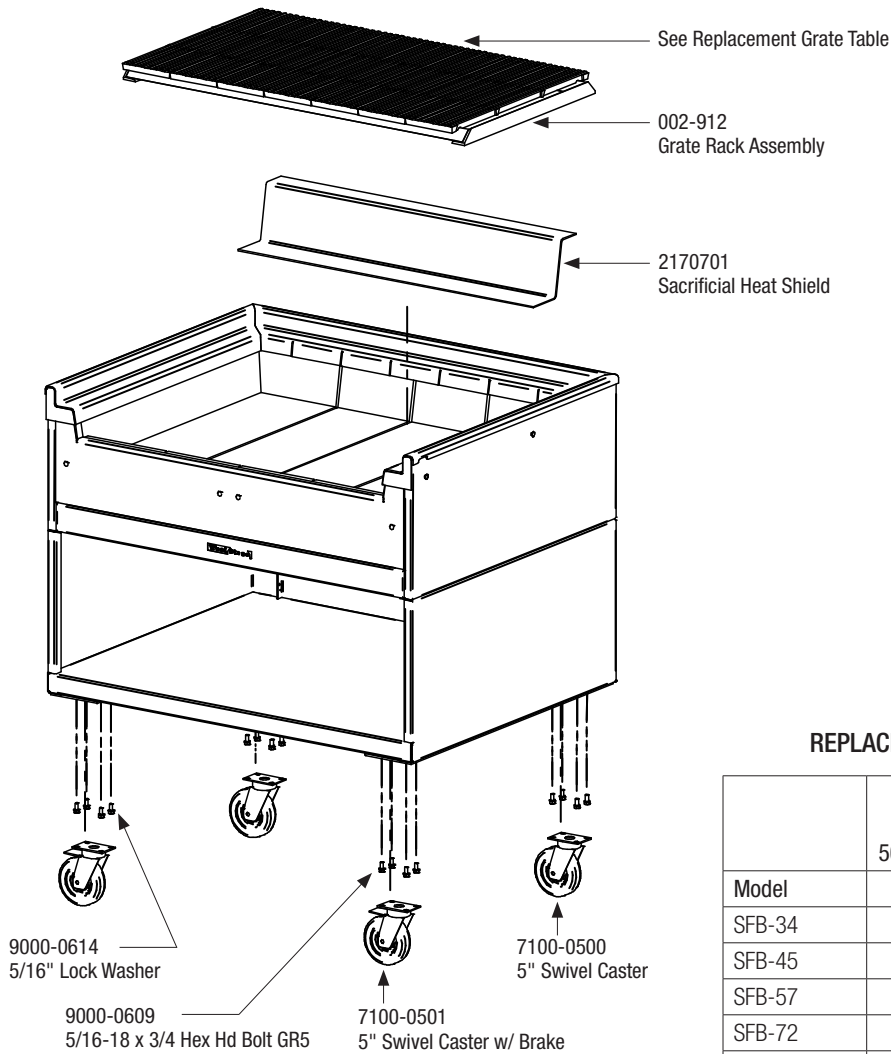

REPLACEMENT GRATE QUANTITY GUIDE

	6x24" Grates 50RO-0017	4x24" Grates 50RO-0017-1	6x16" Grates 50RO-0017-2
Model			
SFB-34	5		
SFB-45	7		
SFB-57	9		
SFB-72	10	2	
SFB-5426			8
SFB-34-CT	5		
SFB-45-CT	7		
SFB-57-CT	9		
SFB-72-CT	10	2	
SFB-5426-CT			8



ALL WARRANTY SERVICE MUST BE PRE-APPROVED BY WOOD STONE

Wood Stone warrants its equipment to the original purchaser against defects in material or manufacture for a period of one year from the original date of purchase, subject to the following exclusions and limitations.

Please contact the factory first at 1.800.988.8103 or 1.360.650.1111, seven days a week. Our normal business hours are 8am to 5pm PST Monday–Friday. If calling during non-business hours, follow the recorded instructions for emergency service and a Wood Stone technician will get back to you promptly.

EXCLUSIONS

The warranties provided by Wood Stone do not apply in the following instances:

1. In the event that the equipment is improperly installed. Proper installation is the responsibility of the installer; proper installation procedures are prescribed by the Wood Stone Installation and Operation Manual.
2. In the event the equipment is improperly or inadequately maintained. Proper maintenance is the responsibility of the user; proper maintenance procedures are prescribed in the Wood Stone Installation and Operation Manual. Burner problems resulting from debris or ash in the burner well will not be covered by the warranty. Call with questions regarding maintenance frequency.
3. In the event that the failure or malfunction of the appliance or any part thereof is caused by abnormal or improper use or is otherwise not attributable to defect in material or manufacture.
4. In the event that the appliance, by whatever cause, has been materially altered from the condition in which it left the factory.
5. In the event that the rating plate has been removed, altered or obliterated.
6. On parts that would be normally worn or replaced under normal conditions.
7. Normal cracking due to expansion and contraction stress relief in the ceramic firebox.
8. In wood-fired equipment configurations, in the event that pressed log products of any type have been burned in the equipment.
9. In coal-fired oven configurations, in the event any type of coal other than anthracite coal fuel has been used.
10. Damage resulting from the use of chemical cleaning products in the oven, as well as any damage from liquids or chemicals, including water, being poured or sprayed into the oven.

If any oral statements have been made regarding this appliance, such statements do not constitute warranties and are not part of the contract of sale. This Limited Warranty constitutes the complete, final and exclusive statement with regard to warranties.

THIS LIMITED WARRANTY IS EXCLUSIVE AND IN LIEU OF ALL OTHER WARRANTIES WHETHER WRITTEN, ORAL OR IMPLIED, INCLUDING, BUT NOT LIMITED TO, ANY WARRANTY OF MERCHANTABILITY OR FITNESS FOR PARTICULAR PURPOSE OR WARRANTY AGAINST LATENT DEFECTS.

LIMITATIONS OF LIABILITY

In the event of warranty claim or otherwise, the sole obligation of Wood Stone shall be the repair and/or replacement, at the option of Wood Stone, of the appliance or component or part thereof. Such repair or replacement shall be at the expense of Wood Stone with the exception of travel over 100 miles or two hours, overtime, and holiday charges which shall be at the expense of the purchaser. Any repair or replacement under this warranty does not constitute an extension of the original warranty for any period of the appliance or for any component or part thereof. Parts to be replaced under this warranty will be repaired or replaced at the option of Wood Stone with new or functionally operative parts. The liability of Wood Stone on any claim of any kind, including claims based on warranty, expressed or implied, contract, negligence, strict liability or any other theories shall be solely and exclusively the repair or replacement of the product as stated herein, and such liability shall not include, and purchaser specifically renounces any rights to recover, special, incidental, consequential or other damages of any kind whatsoever, including, but not limited to, injuries to persons or damage to property, loss of profits or anticipated profits, or loss of use of the product.

TO SECURE WARRANTY SERVICE

If you claim a defect covered by this Limited Warranty, contact:

Wood Stone Corporation, Attn: Service Department, 1801 W. Bakerview Rd., Bellingham, WA 98226 USA
Phone 1.800.988.8103 or 1.360.650.1111

This page left blank, with intention.

This page left blank, with intention.



WOOD STONE CORPORATION

1801 W. Bakerview Rd.
Bellingham, WA 98226 USA

Toll Free 800.988.8103

Tel 360.650.1111

Fax 360.650.1166

www.woodstone-corp.com

An ongoing program of product improvement may require us to change specifications without notice.