

Installation and Operation Manual



CASCADE

Rotisserie

Gas-Fired Rotisserie, Six- and Ten-Spit Models

CASCADE WS-GFR-6

CASCADE WS-GFR-10

Wood Stone

WOOD STONE CORPORATION

1801 W. Bakerview Rd.
Bellingham, WA 98226 USA

Toll Free 800.988.8103

Tel 360.650.1111

Fax 360.650.1166



TABLE OF CONTENTS

Cascade Gas-Fired Rotisserie 3
Cautions & Warnings 4
Specifications 6
Receiving the Rotisserie 7
Installation 8
Clearances & Venting 9
Utility Specifications 10
Utility Connections 12
Controllers 13
Daily Operation 14
Optional Accessories 17
Preventive Maintenance 19
ELECTRICAL DIAGRAMS
120VAC 20
240VAC 22
Line Diagram 24
Limited Warranty 25



**INSTALLATION AND OPERATION MANUAL FOR THE
WOOD STONE CASCADE ROTISSERIE**

STONE FIRED COOKING EQUIPMENT

WS-GFR-6 (SIX SPIT)

AND WS-GFR-10 (TEN SPIT) MODELS

GAS-FIRED ROTISSERIE

ADDITIONAL COPIES AVAILABLE UPON REQUEST



WS-GFR-6 shown with left side
drive and Air Block Panel

**INSTALLATION AND OPERATING INSTRUCTIONS FOR THE GFR-(6, 10)-(NG, LP)
WOOD STONE CASCADE GAS-FIRED ROTISSERIE****RETAIN THIS MANUAL FOR FUTURE REFERENCE**Additional copies of this manual at woodstone-corp.com.

For prompt responses to service/maintenance questions, call us at @ 1-800-988-8103.

READ ALL INSTRUCTIONS BEFORE INSTALLING AND USING THE APPLIANCE

Please read this entire manual before you install the oven. Failure to follow instructions may result in property damage, bodily injury or even death. Contact your local building or fire officials concerning any installation restrictions or the need for inspection of the oven installation in your area.

IMPORTANT: Consult your local gas supplier for a statement outlining a procedure to be followed in the event you smell gas. Post the statement in a prominent location.

It is recommended that this oven be installed, maintained and serviced by authorized professionals.

FOR YOUR SAFETY: Do not store or use gasoline or other flammable vapors or liquids in the vicinity of this or any other appliance.

POUR VOTRE SÉCURITÉ: Ne pas entreposer ni utiliser d'essence ou d'autres vapeurs de liquides inflammables ou des liquides dans les environs de ce ou de tout autre appareil.

DO NOT USE PRODUCTS NOT SPECIFIED FOR USE WITH THIS OVEN.

WARNING: Improper installation, adjustment, alteration, service or maintenance can result in property damage, injury or death. Read the installation, operation and maintenance instructions thoroughly before installing or servicing this equipment.

AVERTISSEMENT: L'installation, le réglage, la modification, la réparation ou l'entretien incorrect de cet appareil peut causer des dommages matériels, de blessures ou la mort. Lire attentivement les instructions d'installation, de fonctionnement et d'entretien avant de procéder à son installation ou entretien.

Always keep the area under and around this appliance free and clear of any and all combustible materials.



A MAJOR CAUSE OF FIRES IS FAILURE TO MAINTAIN REQUIRED CLEARANCES (AIR SPACES) TO COMBUSTIBLE MATERIALS. IT IS OF THE UTMOST IMPORTANCE THAT THIS APPLIANCE BE INSTALLED ONLY IN ACCORDANCE WITH THESE INSTRUCTIONS.

WHEN THE OVEN IS NOT PROPERLY INSTALLED, A FIRE MAY RESULT. TO REDUCE THE RISK OF FIRE, FOLLOW THE INSTALLATION INSTRUCTIONS.

IN THE EVENT OF A POWER FAILURE, NO ATTEMPT SHOULD BE MADE TO OPERATE THIS APPLIANCE.

WARNING: Do not pack required air space with insulation or other material.

AVERTISSEMENT: Ne pas emballer l'espace d'air requis avec de l'isolation ou d'autres matériaux.

This product must be installed by a licensed plumber or gas fitter when installed within the Commonwealth of Massachusetts.

SAVE THE INSTRUCTIONS

The Wood Stone rotisseries have been tested and approved by Intertek Testing Services and conform to ANSI Z83.11:2016 Ed. 4; is certified to CSA 1.8:2016 Ed. 4 and CGA 2.17, and to NSF/ANSI 4:2016.



Intertek
ANSI Z83.11
CSA 1.8



Intertek
ANSI/NSF 4



The only difference between the GFR-6 and GFR-10 is the number of spits. All other dimensions are the same.

Plan view

Shown: Right-hand drive. Left-hand drive models mirror the right-hand drive models exactly.

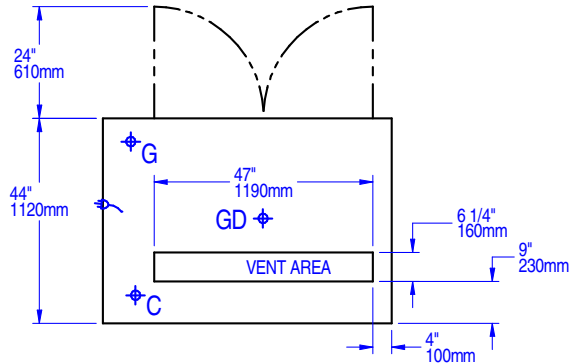

Rear view

(determines drive side)

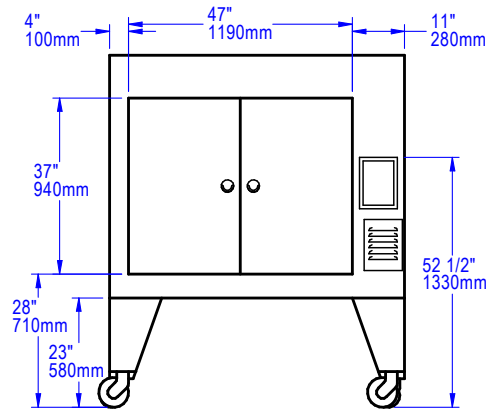

Front view

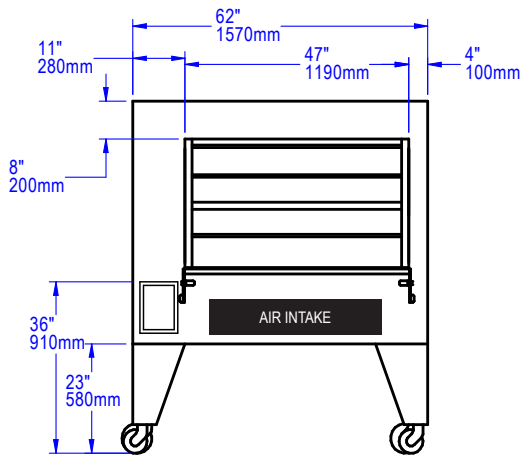

Side view

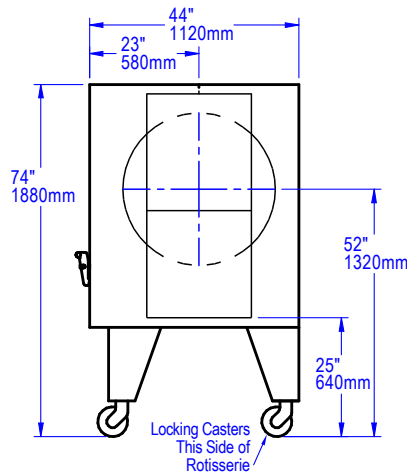

Spit placement

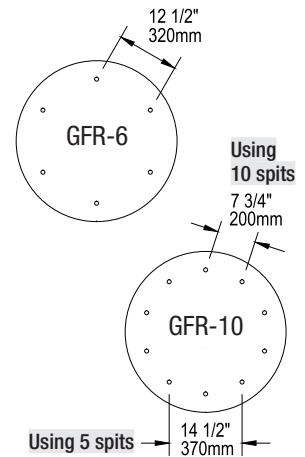

UTILITIES SPECIFICATIONS

Gas ⚡

1 inch FNPT gas inlet
175,000 BTU/hr Natural Gas (NG)

OR

185,000 BTU/hr Propane (LP)
Maximum gas inlet pressure
1/2 psi (14 inches W.C.)

Electrical ⚡

120 VAC, 5 A, 50/60 Hz (NEMA 5-15 plug)
240 VAC, 2 A, 50/60 Hz (plug by others)

Water

Inlet: 1/4" FNPT ⚡C

Drain: 1-1/2" outlet tube ⚡GD

All utility connections made on bottom of the unit.
Refer to data plate when installing.

Venting

The Cascade Rotisserie must be vented using a Listed Type 1 exhaust hood, or one constructed in accordance with NFPA 96 and all relevant local and national codes, and in a manner acceptable to the authority having jurisdiction.

Shipping Weight: 1,500 lbs.



UNLOADING THE ROTISSERIE

The crated Cascade Rotisserie weighs 1,500 lbs. A 2,000 lb. capacity forklift with extensions should be used for unloading the unit from the delivery vehicle. Approach the crated rotisserie from the side and insert the evenly spaced forks under the wooden skid.

MOVING THE ROTISSERIE

The crated rotisserie can be moved using a forklift, if space allows. Alternatively, a 2,000 lb. pallet jack can be used.

DO NOT ATTEMPT TO MANUALLY ROLL THE OVEN UP OR DOWN A RAMP OR INCLINE. Do not position yourself between the moving oven and an immovable object or surface such as a wall or door frame.

UN-CRATING THE ROTISSERIE

Position the forklift at the front or rear of the rotisserie. Adjust the forks so that they are just narrow enough to fit within the stainless angles on the bottom of the unit. Remove the crating. **Do not rest the rotisserie on the stainless angles.** If the rotisserie must be set down before the legs are mounted, support the unit using appropriately arranged blocks which extend beyond the sides.

LEG / CASTER POSITIONING & ASSEMBLY

The legs/casters of the rotisserie must be installed in its proper position prior to setting the unit in place. Each leg is numbered, corresponding to the number written on the underside corners of the cabinet body.

The rotisserie must be raised more than 23 inches from the floor in order to mount the legs. Each leg is firmly attached using the four 3/4 inch bolts provided. Once all four legs are securely attached, the rotisserie can be lowered into place. **Seal all legs to the cabinet using the silicone sealant provided.**

AIR BLOCK PANEL INSTALLATION

The Air Block Panel is removed for shipping, and must be reinstalled after the legs/casters are installed.

Align skirting with the pre-tapped holes in the legs and attach with (6) 1/4-20 x 1/2" stainless steel pan head machine screws (supplied) as shown at right.

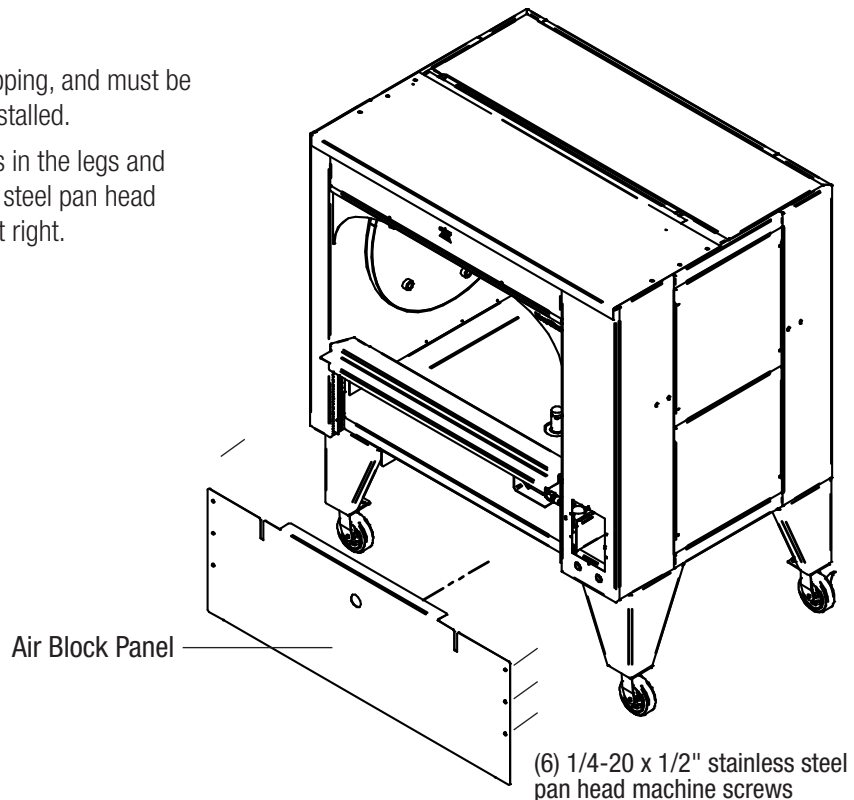



IMPORTANT NOTICE FOR GAS CONNECTION TO MOVABLE APPLIANCES

When this appliance is installed with casters, it must be installed with the casters supplied, a connector complying with either ANSI Z21.69 or CSA 6.16 and a quick disconnect device complying with ANSI Z21.41 or CSA 6.9. It must also be installed with restraining means to guard against transmission of strain to the connector, as specified in the appliance manufacturer's instructions.

ATTENTION INSTALLER: EQUIPMENT RESTRAINT MUST BE PROVIDED

Adequate means must be provided to limit the movement of the appliance without depending on the connector and the quick disconnect device or its associated piping to limit the appliance movement. Use the holes in the lower rails of the rotisserie cabinet and charbroiler table to attach the restraining device(s).

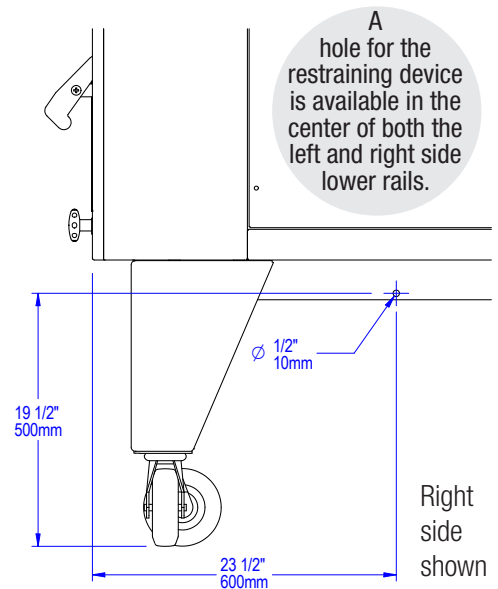



INSTALLATION CLEARANCES

SIDES AND TOP

- Minimum clearance from sides and top of rotisserie to **combustible** construction is **36"**.
- Minimum clearance from sides and top of rotisserie to **non-combustible** construction is **0"**.

FLOOR

- The unit is suitable for installation on **combustible** floors.

WARNING: Do not pack required air spaces with insulation or other material. Do not obstruct the flow of combustion and ventilation air.

VENTING

The Wood Stone Cascade Gas-Fired Rotisserie must be vented using a Listed Type 1 exhaust hood or one constructed in accordance with the Standard for Ventilation Control and Fire Protection of Commercial Cooking Operations, NFPA 96, and all relevant local and national codes, and in a manner acceptable to the authority having jurisdiction. It is never appropriate to use "B vent" in any part of an exhaust system connected to this rotisserie.

VERY IMPORTANT! WOOD STONE RECOMMENDS THAT YOU SUBMIT VENTING PLANS TO LOCAL CODE AUTHORITIES BEFORE PROCEEDING WITH INSTALLATION.

SERVICE PANEL ACCESS

Drive-side Service Panels will need to be removed during the assembly of, and utility connection to, the rotisserie. All obstructions 5' from drive side only of unit must be removable for service access.

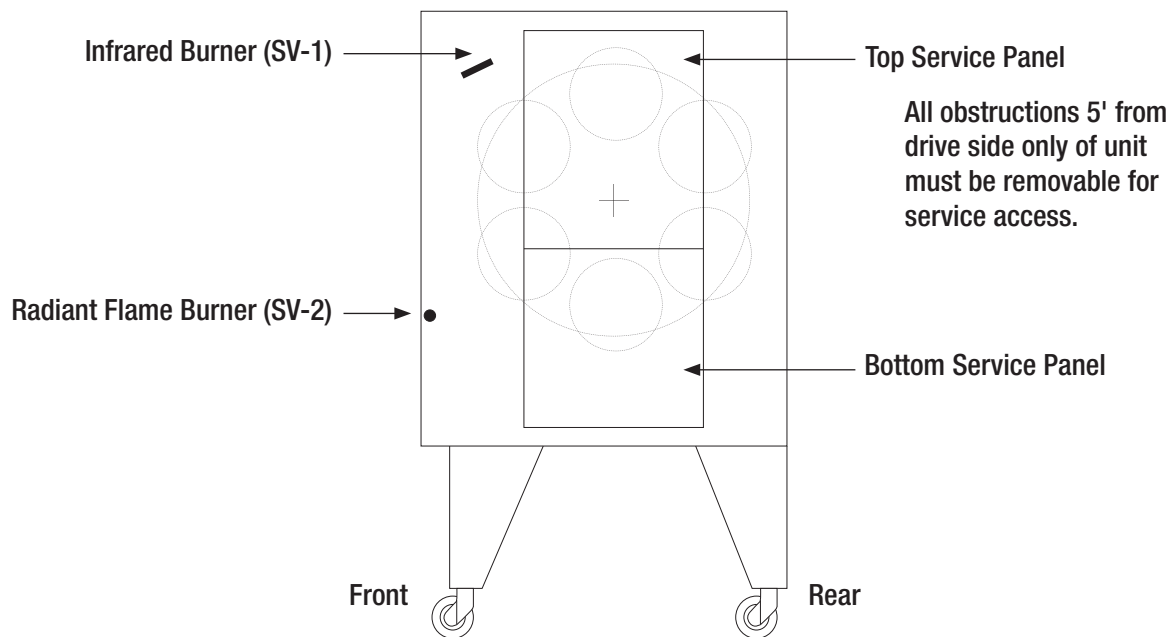



GAS SPECIFICATIONS

FACTORY SPECIFIED INDIVIDUAL BURNER MANIFOLD PRESSURES FOR WS-GFR MODELS			MAXIMUM HOURLY BTU INPUT RATES FOR WS-GFR MODELS		
Model	Natural Gas (NG)	Propane (LP)	Model	Natural Gas (NG)	Propane (LP)
WS-GFR	4.0" W.C.	8.0" W.C.	WS-GFR	175,000	185,000

This oven requires no modifications or adjustments for use at high altitudes.

The installation of this appliance must conform with local codes, or in the absence of local codes, with the National Fuel Gas Code, ANSI Z223.1 or The Natural Gas Installation Code CAN/CGA-B149.1 as applicable.

SV-1 is the gas control valve that operates the upper Infrared (IR) Burner. The manifold pressure is checked at the outlet port on the SV-1 gas valve.

SV-2 is the gas control valve that operates the lower Radiant Burner. The manifold pressure is checked at the outlet port on the SV-2 gas valve.

The burner manifold pressures have been adjusted and tested at the factory. A variety of factors can influence these pressures, so be sure to test the individual burner manifold pressures and adjust the valves as necessary to achieve the required pressures.

NOTE: The gas valves are shipped in the **ON** position.

GAS CONNECTION

The Cascade Gas-Fired Rotisserie is equipped with a 1-inch FNPT gas connection (see the UTILITY CONNECTIONS section for exact location). Have a licensed gas installer provide the hook-up and test all fittings and pipe connections for leaks. Use approved gas leak detectors (soap solutions or equivalent) over and around the fittings and pipe connections. **DO NOT USE A FLAME TO TEST FOR LEAKS!**

All gas piping up to the oven must have a minimum inside diameter of 1", including all fittings and shut off valves, which should be of the full flow type.

Wood Stone recommends that the rotisserie be equipped with a manual, individual shutoff valve, located between the oven and the main gas supply, and that this shutoff valve (supplied by others) be left readily accessible. Wood Stone also recommends that inspection and maintenance of the burners and gas piping connections of this appliance be performed at regularly scheduled intervals and only by professional gas appliance service agencies.

Maximum inlet gas pressure must not exceed 14" W.C. (1/2 psi)

GAS INLET PRESSURE

For ovens running on natural gas, an inlet pressure of 7 to 10" W.C. is recommended to ensure optimum oven performance. Incoming gas pressure below this range will affect oven performance, the lower the pressure the greater the negative impact. If the gas supply pressure is greater than 14" W.C. (1/2 psi), an external regulator, supplied by others, is **REQUIRED** to lower the gas pressure to the acceptable range. Issues caused by low or high gas pressure are installation issues, and will not be covered under the Warranty.

For ovens running on LP, the recommended inlet pressure to ensure optimum oven performance is 10 to 12" W.C. Incoming gas pressure below this range will affect oven performance, the lower the pressure the greater the negative impact. If the gas supply pressure is greater than 14" W.C. (1/2 psi), an external regulator, supplied by others, is **REQUIRED** to lower the gas pressure to the acceptable range. Issues caused by low or high gas pressure are installation issues, and will not be covered under the Warranty.



For all installations, follow best practices for proper gas line pipe sizing for the line serving the oven. To insure proper operation, all gas piping and fittings leading up to the oven should have an inside diameter equal to or greater than that of the oven gas connection. Also make sure that a readily accessible shut off valve (supplied by others) is installed near the oven, and in accordance with all applicable codes. Shut off valves must be of the full-flow type, and not introduce any restriction into the gas line.

The connection to the oven should be hard-piped whenever feasible. If this is not possible, use a properly sized flexible connector approved for this application. When using a flexible connector make sure that its design does not present any reduction in pipe diameter or other restriction. Oven issues caused by improper pipe sizing, improper shut off valves, restrictive connectors, or any other deficiency in the gas supply design or installation will not be covered under the oven warranty.

GAS CODE LIMITATIONS

The installation of this appliance must conform with local codes, or in the absence of local codes, with the National Fuel Gas Code, ANSI Z223.1 or The Natural Gas Installation Code CAN/CGA-B149.1 as applicable.

The appliance and its individual shutoff valve (supplied by others) must be disconnected from the gas supply piping system during any pressure testing of that system at test pressures in excess of 14" W.C. (1/2 psi) (3.45 kPa).

The appliance must be isolated from the gas supply piping system by closing its individual manual shutoff valve (supplied by others) during any pressure testing of the gas supply piping system at test pressure, equal to or less than 14" W.C. (1/2 psi) (3.45 kPa).

PRESSURE TESTING

There are (2) pressure test ports (one for each burner), located on the respective valves. The valve outlet pressures have been adjusted and tested at the factory. A variety of factors can influence these pressures, so be sure to test the valve outlet pressures and adjust the valves as necessary to achieve the suggested pressures. **NOTE:** The gas valves are shipped in the ON position.

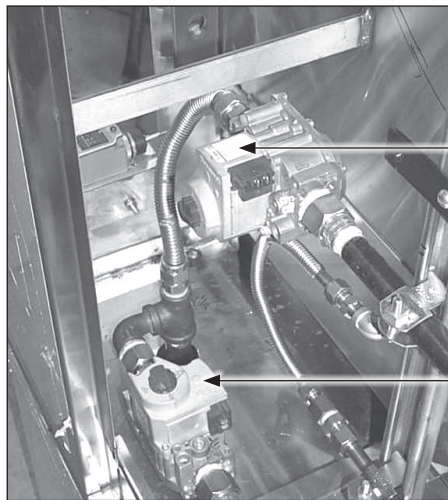

Infrared (IR)
Burner (SV-1)

Radiant Flame
Burner (SV-2)

View from the service panel showing the gas control valves

ELECTRICAL SPECIFICATIONS

Electrical grounding: This appliance must be electrically grounded in accordance with local codes, or in the absence of local codes, with the National Electrical code, ANSI/NFPA 70 or the Canadian Electrical Code, CSA C22.1 as applicable.



UTILITY CONNECTIONS

NOTE: This unit is on casters, so utility hookups should be made in such a way as to allow mobility of the rotisserie for service and maintenance purposes.

All connections to the rotisserie are made from the bottom of the unit.

- A. Electrical connection
(120 VAC, 5 A)
- B. Cold water inlet
(1/4" FNPT)
- C. Drain to floor sink
(1-1/2"; use slip connection)
- D. Gas inlet
(1" FNPT)

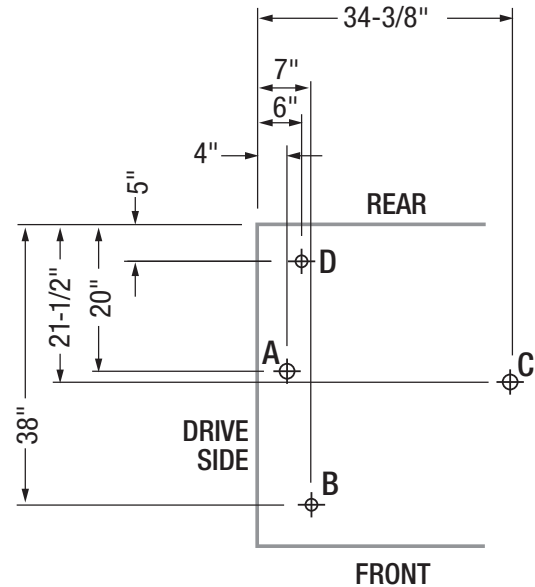
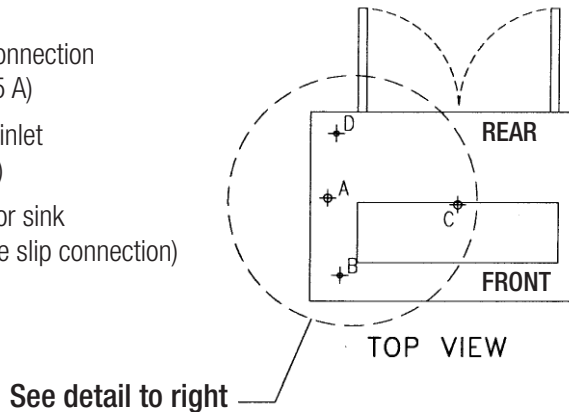

ELECTRICAL CONNECTION

Use only the grounded cord provided to make the electrical connection to the rotisserie. Plug only into a properly grounded 3-prong receptacle. Do not cut or remove the grounding prong from the plug. The cord is attached to the rotisserie at the IEC connection on the bottom of the unit, with a NEMA 5-15 plug.

COLD WATER INLET

Supply an incoming cold water line fitted with a 1/4" NPT (male) connector.

DRAIN TO FLOOR SINK (GREASE TRAP)

A 1-1/2" drain outlet tube at the bottom of the rotisserie is provided. This outlet must be connected to an indirect waste pipe and discharge by means of an air gap in accordance with all applicable plumbing codes. The indirect waste pipe should discharge into a drain system that is serviced by a grease trap.

GAS CONNECTION

Supply an incoming gas line sufficient to provide the required input. The gas line will need to be fitted with a 1-inch MNPT connector. See pages INSTALLATION and UTILITY SPECIFICATIONS sections for more information.



USED ON ALL MODELS WITH DUAL FRONT / REAR CONTROLS

FRONT CONTROLLER

RED: Stops both burners and rotisserie drum

GREEN: Starts rotisserie drum (when rear doors are open, depressing the button will jog the drum).

Water Valve Knob

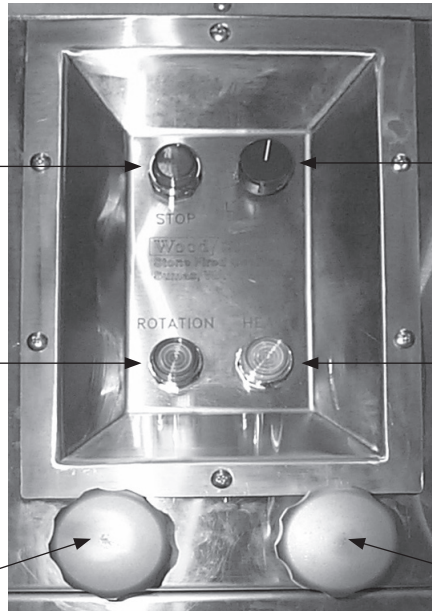

BLACK: Rotisserie drum Speed Control Knob

YELLOW: Lights both burners (rotisserie drum must be activated before burners will light).

Gas Throttle Knob

REAR CONTROLLER

RED: Stops both burners and rotisserie drum

Circuit Breaker
(push to reset)

GREEN: Starts rotisserie drum (when rear doors are open, depressing the button will jog the drum).



YELLOW: Lights both burners (rotisserie drum must be activated before burners will light).

ALWAYS WAIT FIVE MINUTES BEFORE ATTEMPTING TO RELIGHT THE BURNERS.



BEGINNING OF DAY

FILLING THE WATER BATH

To fill the water bath, turn the Water Valve Knob counter clockwise (to the left). The water bath should always be filled to the level of the drain stand pipe when the rotisserie is in operation. Failure to fill the cabinet with water can result in warping of the cabinet and fire hazard from grease accumulation. Wood Stone recommends allowing the water to trickle into the tray while the rotisserie is in use to allow grease to flow safely out of the cabinet through the drain (which must be connected to a grease trap).

DAILY OPERATION

LOADING/UNLOADING THE ROTISSERIE

Open both doors to load the rotisserie. The drum will stop automatically anytime the rear doors are opened. To advance the rotisserie drum with the doors open, simply push and hold the **GREEN** start rotation button, which will now act like a jog button. Release the button when the rotisserie drum reaches the desired position and it will stop. When loading, make certain product does not hit the back wall or the optional smoker box as the drum turns. Note: Drum rotates from the bottom up.

**NEVER ATTEMPT TO PLACE OR REMOVE SPITS WHEN THE ROTISSERIE DRUM IS MOVING.
BURNERS WON'T TURN ON IF DRUM IS NOT TURNING.**

LOADING THE SPITS

The spits can only be inserted into the rotisserie drive one way. When loading the rotisserie, make sure the load is evenly distributed by loading equally weighted spits and/or baskets opposite each other. The round end of the spit or basket is always inserted first. Push the round end of the spit into the hole until there is clearance to insert and seat the square end into its socket. Be sure to fully seat the spit so that it locks into place and the round end will rotate freely when the drum turns.

GFR-6 CAPACITY

The 6-spit GFR-6 model has a total capacity of 36–42 chickens weighing 2.5 lbs each, or 18–24 chickens for the narrow model.

GFR-10 CAPACITY

With the 10-spit GFR-10 model, when using all 10 spits, the operational maximum product load will be approximately 6–7 chickens weighing 2.5 lbs each per spit.

To load larger product, it is possible to run the rotisserie with five spits, removing every other spit for balance.

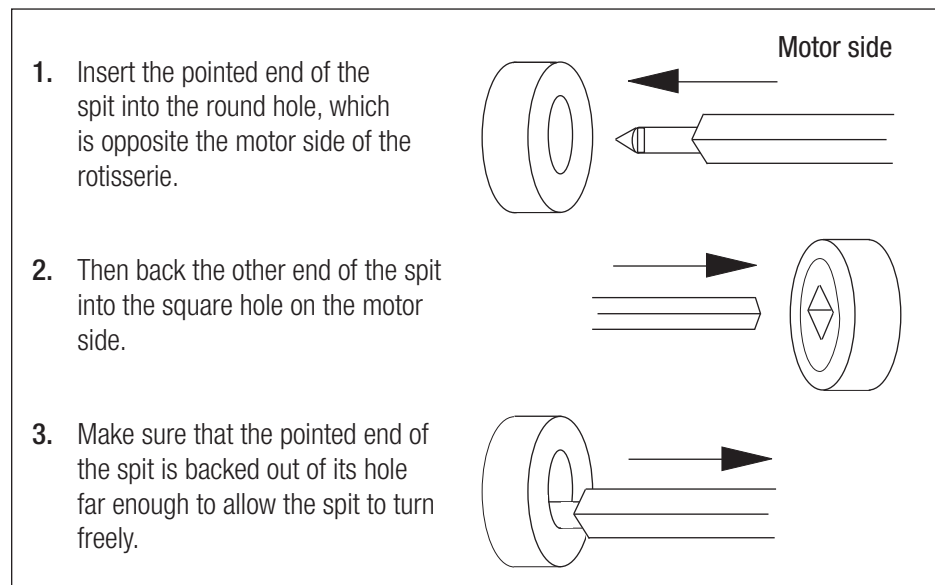



ADJUSTING THE FLAME HEIGHT

To increase the height of the radiant flame, turn the gas throttle knob (below and to the right of the front controller) counter clockwise (to the left). To reduce the height of the radiant flame, turn the gas throttle knob clockwise (to the right).

ADJUSTING DRUM ROTATION SPEED

Turning the **BLACK** drum speed control knob counterclockwise slows rotation of the drum; turning it to the right will increase the speed. For most cooking situations, setting the knob at the midpoint (with the white indicator line straight up) is a good place to start.

STOPPING THE DRUM ROTATION AND BURNERS

There are four ways to stop the drum rotation and burners with standard back door models).

1. Push the bump-bar style shut-off on the front of the rotisserie - all models
2. Push the **RED** button on the Front Controller - all models
3. Push the **RED** button on the Rear Controller on standard back door models
4. Open the rear door - if equipped

TO RESTART THE ROTISSERIE & BURNERS

Close the doors and first push the **GREEN** start rotation button and then the **YELLOW** start flame button. The speed of the rotisserie can be adjusted using the **BLACK** drum speed control knob located on the controller. **Always wait 5 minutes before attempting to relight the burners.**

TROUBLESHOOTING

If drum fails to start after depressing **GREEN** start rotation button:

1. Check the circuit that oven is connected to at the outlet and/or circuit breaker.
2. Check that power cord is securely connected to the rotisserie and at the outlet. Check that the cord is not damaged.
3. Press the Push Button Circuit Breaker, located in center of Controller.
4. If the above do not solve the problem, call Wood Stone.

SPIT LOCATIONS

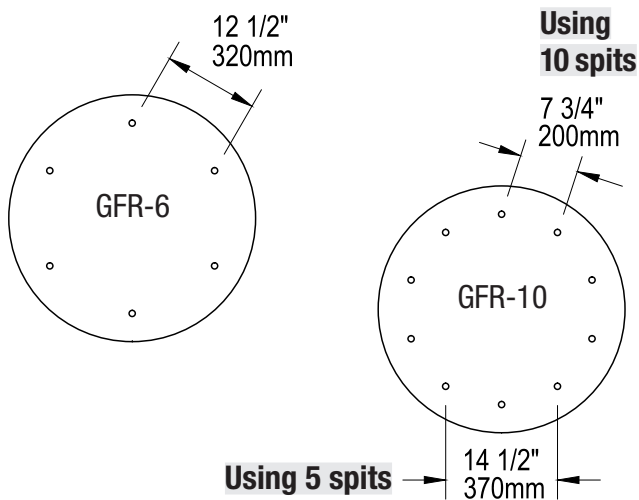



END OF DAY

CLEANING THE ROTISSERIE CABINET (INTERIOR)

Pull out the Drain Stand Pipe and allow the water to flow down the drain. With a warm damp cloth, wipe up any grease remaining in the cabinet. A squeegee can also be used to remove grease. Then use a clean dry cloth to dry and polish the surface. For serious build-up, a commercial oven cleaner can be used—follow the directions supplied with the product.

DO NOT attempt to clean the burners. Take care when cleaning near the burners to avoid contact with the spark igniter assemblies to avoid accidental damage. Never spray water onto or around the burners, or into either of the side compartments on the rotisserie.

CLEANING THE ROTISSERIE CABINET (EXTERIOR)

All exposed surfaces of the rotisserie should be wiped clean daily using an approved mild cleaning solution. Stubborn residues may be removed using a non-metallic scouring pad. When scouring stainless steel, scrub with the grain to avoid scratching the finish.

DO NOT attempt to clean the burners. Take care when cleaning near the burners to avoid contact with the spark igniter assemblies to avoid accidental damage. Never spray water onto or around the burners, or into either of the side compartments on the rotisserie. Do not use excess liquid when cleaning the control panels.

CLEANING THE ACCESSORIES

All rotisserie attachments (spits, forks, basket pins) should be cleaned between uses using an approved mild detergent, hot water, and an approved sanitizing solution. Alternatively, these items can be cleaned in a dishwasher.

EXHAUST HOOD

Refer to the exhaust hood manufacturer's recommendations for inspection, maintenance and cleaning.



A. STANDARD ANGLE SPIT

The Standard Angle Spit is included with all Wood Stone rotisseries. Six to seven average-sized birds can be quickly loaded. The perforations are convenient for securing the string or skewers used to bind the legs.

B. SQUARE SPIT WITH ADJUSTABLE FORKS

The Square Spit With Adjustable Forks is made of half-inch square stock stainless steel and comes with 5 double forks and two single forks. It is easy to load and the forks hold the birds in place so that no binding of the legs is required. This spit holds from 1 to 6 birds of various sizes.

C. CLAMSHELL BASKET

The versatile Clamshell Basket spit is constructed of heavy gauge stainless steel and conveniently adjusts to hold a variety of products, ranging from fresh vegetables to two entire prime ribs. Stainless steel screens are also available to help secure smaller items. Includes Chain Assembly For Clamshell Basket locking mechanism.

D. FISH AND VEGETABLE SCREEN

The 26 x 16" Fish And Vegetable Screen inserted into the Clamshell Basket compartment expands the versatility of the spit.

E. RIB/FISH BASKET SPIT

The Rib/Fish Basket Spit is available in a 3-arm, 6 compartment, or in a 4-arm, 8 compartment model. On the 4-arm spit, each compartment is suitable for a full rack of ribs, a sizeable salmon fillet or several smaller cuts of meat. On the 3-arm spit, the size of each compartment makes it ideal for larger items such as tri-tip roasts and pork loins. The laser-cut containment flap is spring-loaded for easy loading and unloading.

F. FISH AND VEGETABLE SCREEN

The 18 x 6" Fish And Vegetable Screen inserted into the 4-arm version of the Rib/Fish Basket Spit expands the versatility of the spit.

See the Tools and Accessories Catalog on the Wood Stone website for additional details.

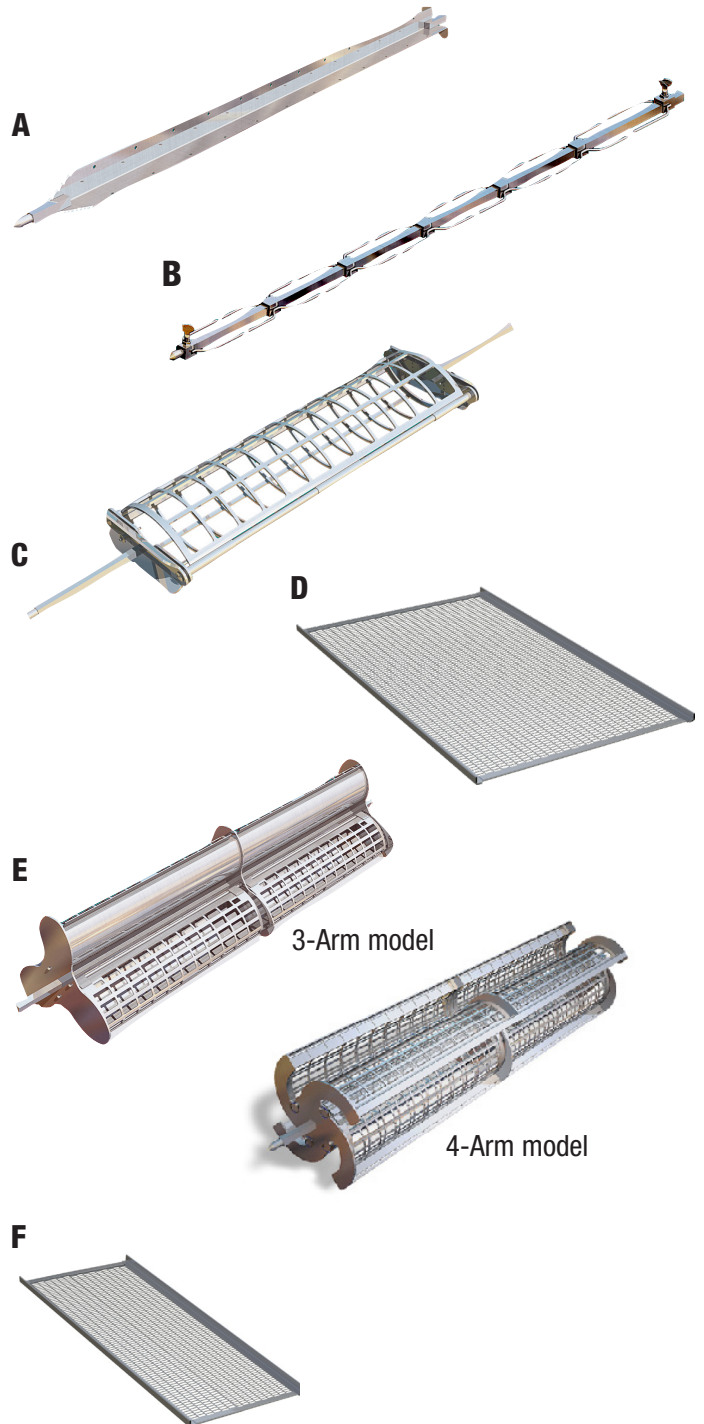



G. PIG SPIT ASSEMBLY

The Pig Spit Assembly features a spit made from half-inch square stainless steel stock, stainless steel end forks and an aluminum back brace. The assembly is suitable for roasting a 30–40 lb suckling pig or lamb.

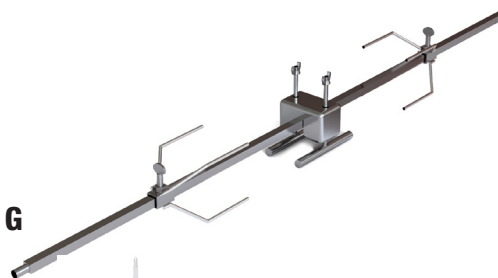

I. SPIT CART

This compact Spit Cart features a sturdy stainless steel body specifically designed to hold rotisserie spits upright. The cart facilitates spit loading and provides spit storage.



J. GFR SMOKER TRAY

The Smoker Tray is a perforated stainless steel box for use with GFR gas-fired rotisserie to help influence flavor. It accommodates approximately 3.5 lbs of well soaked wood pieces and partially ignited charcoal to create smoke. Wood and charcoal can be replenished during the cook cycle to maintain smoke.

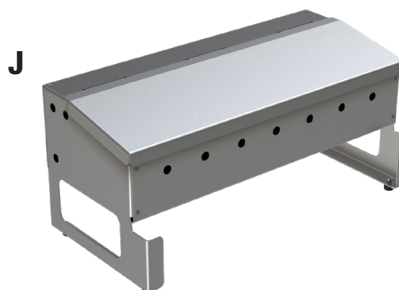

K. SPIT FORKS SINGLE

A stainless steel, single direction Spit Fork, used for holding product in place on a Square Spit.

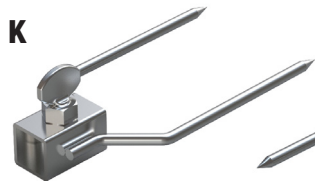

L. SPIT FORKS DOUBLE

A stainless steel, double direction Spit Fork, used to space while and hold product in place on a Square Spit.

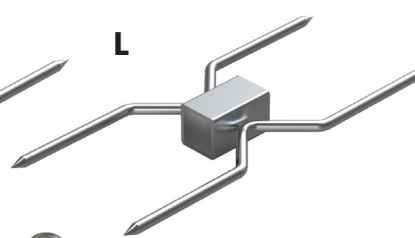

M. CHAIN ASSEMBLY FOR CLAMSHELL BASKET

Replacement locking mechanism for the Clamshell Basket.



N. PUSH RELEASE BASKET PIN

Replacement locking pin on the Chain Assembly For Clamshell Basket.



See the Tools and Accessories Catalog on the Wood Stone website for additional details.



Contact the Wood Stone Service Department or a qualified local service company for any maintenance or repairs.

NOTE: ALWAYS DISCONNECT POWER SUPPLY BEFORE SERVICING THIS APPLIANCE.

MAIN BEARING LUBRICATION (EVERY 12 MONTHS)

The two main shaft bearings should receive one pump of a NLGI Grade 2 lithium-based grease, such as Lubriplate 630-2, every 12 months. These bearings are located inside the cabinet on either end of the main shaft. A Zerk fitting for each bearing is located directly below the top door hinge on either side of the cabinet on the operator (door) side. Care should be taken not to over lubricate these bearings. One pump is sufficient.

MOTOR BRUSHES REPLACEMENT (APPROXIMATELY EVERY 3 YEARS)

The three year replacement recommendation is based upon an average daily use of 10 hours. Contact the Wood Stone Service Department or your local service technician for service.

REDUCTION GEAR LUBRICATION

The gearbox is permanently lubricated and requires no additional maintenance.

SPUR GEAR BUSHING

Check the spur gear bushings for signs of binding or lateral movement where the gear shank passes through the drive end drum. The gear should rotate in the Rulon inner bushing. If the gear and Rulon bushing are rotating in the drum sleeve instead, remove the gears and Rulon bushings, clean and refit. Do not lubricate the bushings or gears. To remove the gears, first mark the drum in relation to the shaft to ensure it is reinstalled in the same position. Remove the six bolts that retain the drum end to the hub and slide the drum end assembly toward the center of the cabinet. The spur gears can now be removed by loosening the set screw retaining the locking collar and sliding the gears out of the drum.

INNER DRUM SEALING

The condition of the high-temperature sealant used to seal the inner drums to the cabinet walls and the inside corners of the cabinet should be checked and renewed if sealant has failed. Use Dow Corning 732 RTV sealant.

DOOR JAMB MICRO SWITCH

Check the jamb switch for proper operation. The switch should move freely in the jamb without sticking or binding and the drums should stop when the doors are opened.

SPEED CONTROL KNOB

Check the speed control potentiometer for proper operation and the knob for tightness.

DOOR LATCH

Check the door latch mechanism for proper operation. If sticking occurs, remove the wedge pin, clean, refit and adjust.

EXHAUST HOOD

Refer to the exhaust hood manufacturer's recommendations for inspection, maintenance and cleaning.



These diagrams can also be found affixed to the inside of the drive-side service panel of the rotisserie.

Mt. Cascade Gas Fired Rotisserie

Electrical Diagram 100/120 V

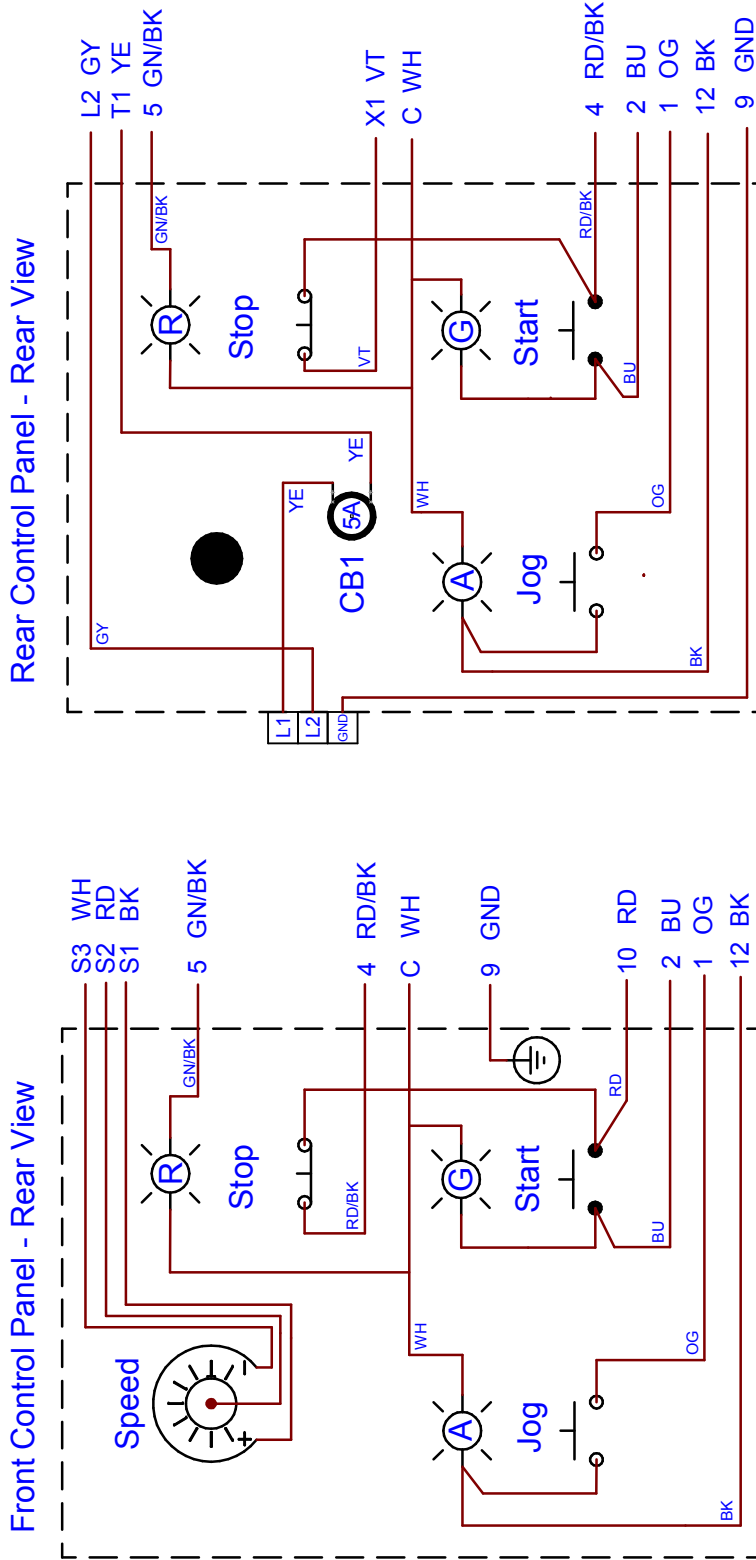

(Used on all models with dual controls—no broiler)

DIAG #: WD242 Rev. 2
DATE: 11/28/2017



DIAG #: WD241 Rev. 3
DATE: 3/2/2018

Mt. Cascade Gas Fired Rotisserie Electrical Diagram 100/120V

These diagrams can also be found affixed to the inside of the drive-side service panel of the rotisserie.

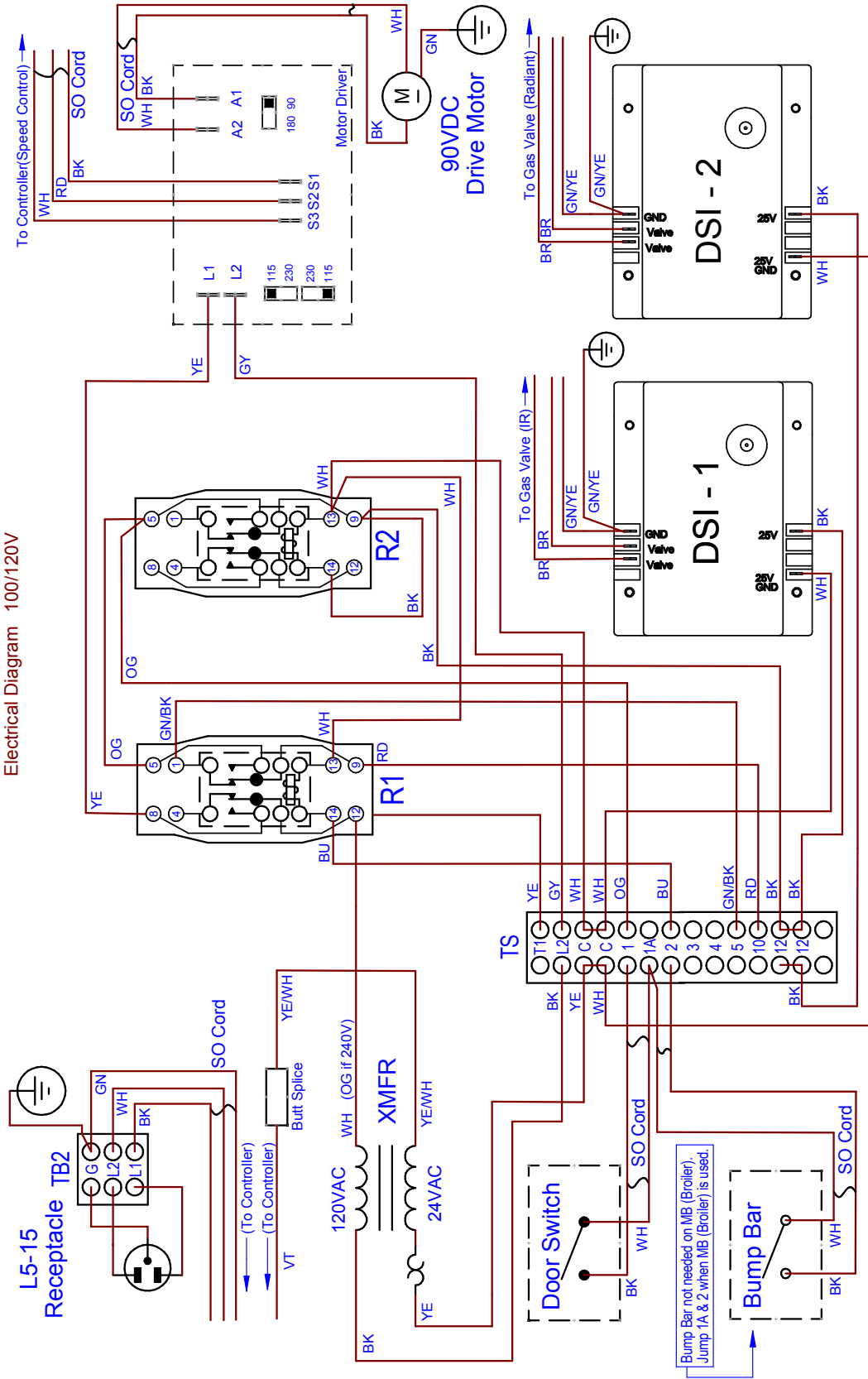



These diagrams can also be found affixed to the inside of the drive-side service panel of the rotisserie.

Mt. Cascade Gas Fired Rotisserie

Electrical Diagram 220/240 V

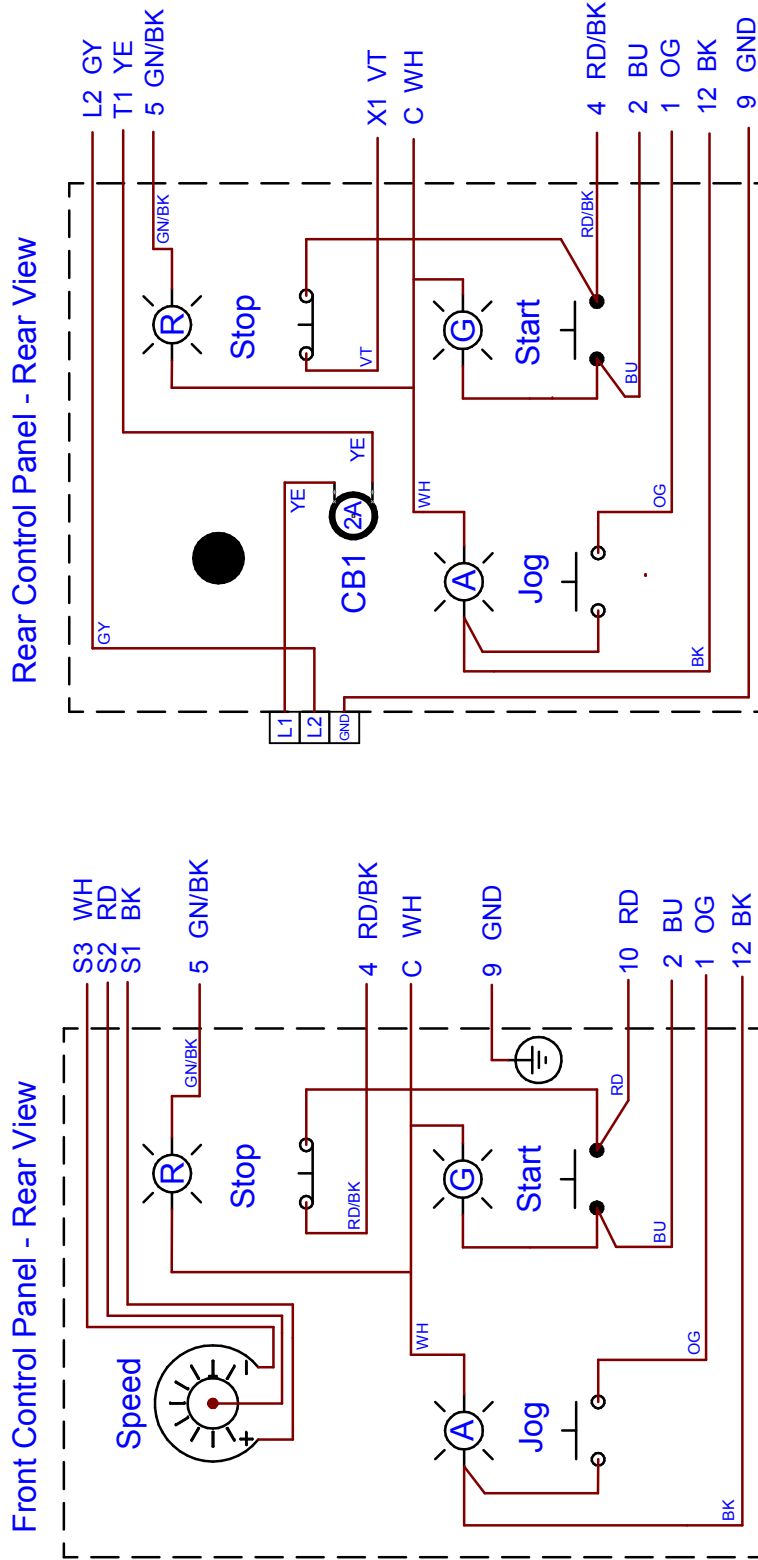

(Used on all models with dual controls—no broiler)



DIAG #: WD243 Rev. 2
DATE: 3/2/2018

Mt. Cascade Gas Fired Rotisserie Electrical Diagram 220/240V

These diagrams can also be found affixed to the inside of the drive-side service panel of the rotisserie.

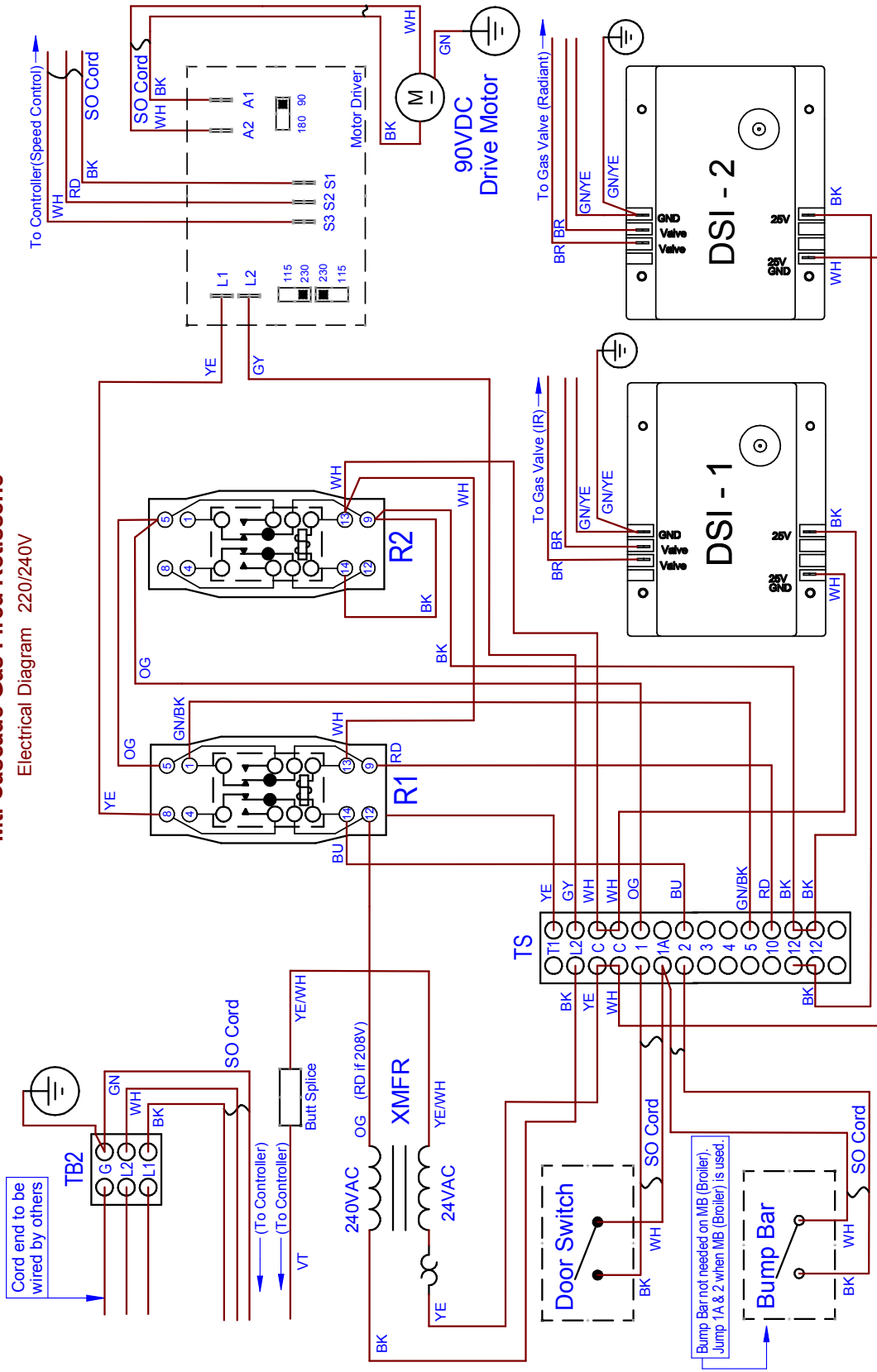



These diagrams can also be found affixed to the inside of the drive-side service panel of the rotisserie.

WS-GFR Electrical Line Diagram (Cascade Gas-Fired Rotisserie)

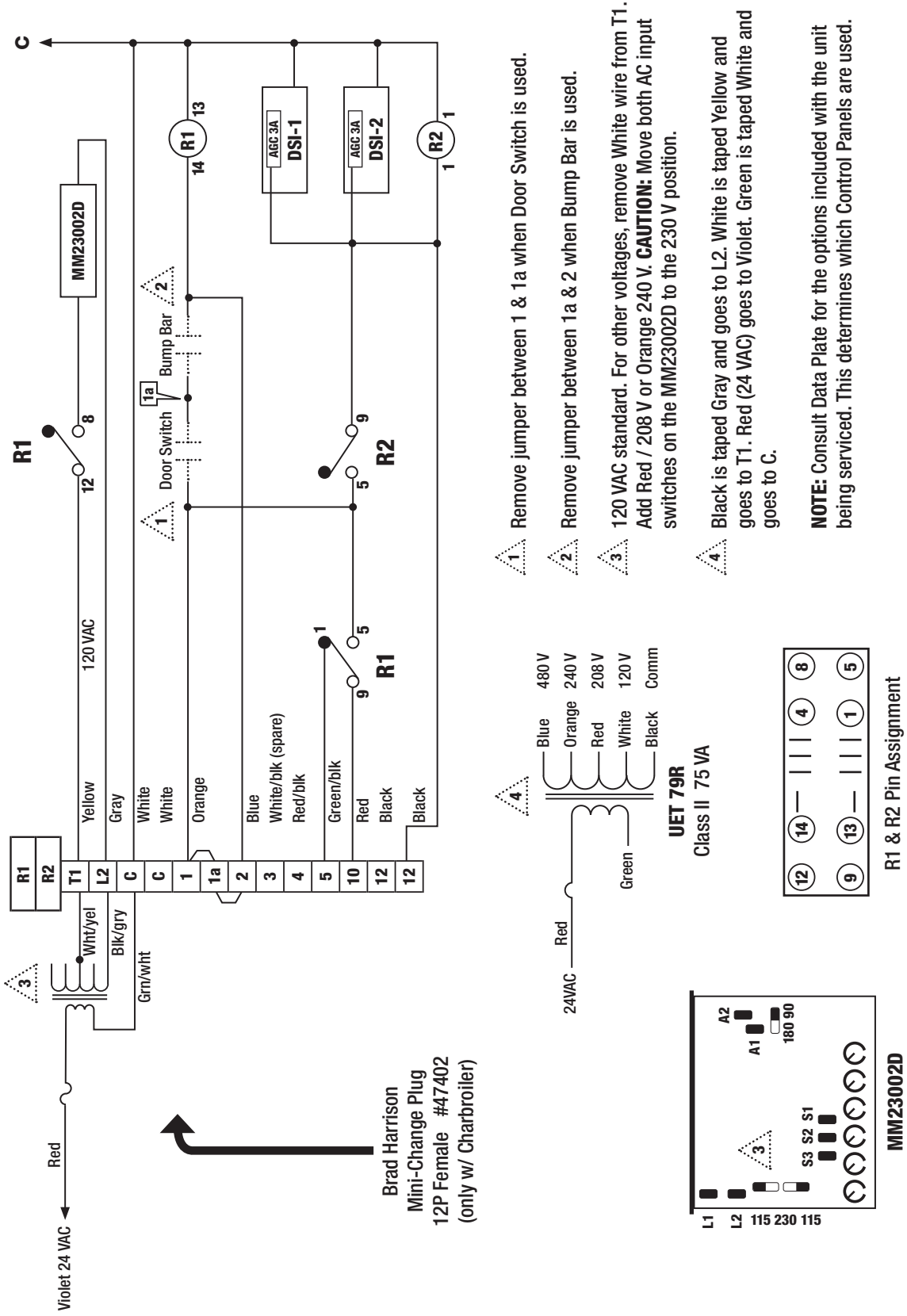

Brad Harrison
Mini-Change Plug
12P Female #47402
(only w/ Charbroiler)

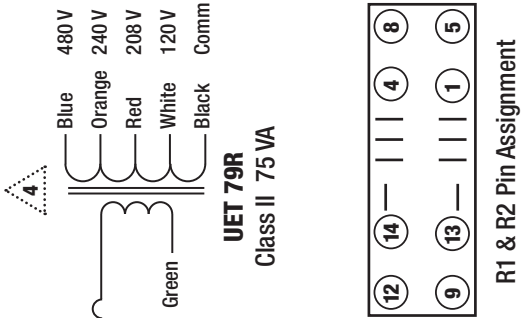
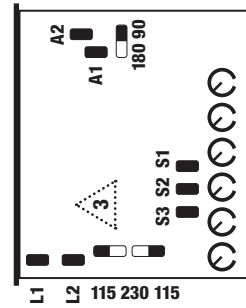



ALL WARRANTY SERVICE MUST BE PRE-APPROVED BY WOOD STONE

Wood Stone warrants its equipment to the original purchaser against defects in material or manufacture for a period of one year from the original date of purchase, subject to the following exclusions and limitations.

Please contact the factory first at 1.800.988.8103 or 1.360.650.1111, seven days a week. Our normal business hours are 8am to 5pm Pacific time Monday–Friday. If calling during non-business hours, follow the recorded instructions for emergency service and a Wood Stone technician will get back to you promptly.

EXCLUSIONS

The warranties provided by Wood Stone do not apply in the following instances:

1. In the event that the equipment is improperly installed. Proper installation is the responsibility of the installer; proper installation procedures are prescribed by the Wood Stone Installation and Operation Manual.
2. In the event the equipment is improperly or inadequately maintained. Proper maintenance is the responsibility of the user; proper maintenance procedures are prescribed in the Wood Stone Installation and Operation Manual. Burner problems resulting from debris or ash in the burner well will not be covered by the warranty. Call with questions regarding maintenance frequency.
3. In the event that the failure or malfunction of the appliance or any part thereof is caused by abnormal or improper use or is otherwise not attributable to defect in material or manufacture.
4. In the event that the appliance, by whatever cause, has been materially altered from the condition in which it left the factory.
5. In the event that the rating plate has been removed, altered or obliterated.
6. On parts that would be normally worn or replaced under normal conditions.
7. Normal cracking due to expansion and contraction stress relief in the ceramic firebox.
8. In wood-fired equipment configurations, in the event that pressed log products of any type have been burned in the equipment.
9. In coal-fired oven configurations, in the event any type of coal other than anthracite coal fuel has been used.
10. Damage resulting from the use of chemical cleaning products in the oven, as well as any damage from liquids or chemicals, including water, being poured or sprayed into the oven.

If any oral statements have been made regarding this appliance, such statements do not constitute warranties and are not part of the contract of sale. This Limited Warranty constitutes the complete, final and exclusive statement with regard to warranties.

THIS LIMITED WARRANTY IS EXCLUSIVE AND IN LIEU OF ALL OTHER WARRANTIES WHETHER WRITTEN, ORAL OR IMPLIED, INCLUDING, BUT NOT LIMITED TO, ANY WARRANTY OF MERCHANTABILITY OR FITNESS FOR PARTICULAR PURPOSE OR WARRANTY AGAINST LATENT DEFECTS.

LIMITATIONS OF LIABILITY

In the event of warranty claim or otherwise, the sole obligation of Wood Stone shall be the repair and/or replacement, at the option of Wood Stone, of the appliance or component or part thereof. Such repair or replacement shall be at the expense of Wood Stone with the exception of travel over 100 miles or two hours, overtime, and holiday charges which shall be at the expense of the purchaser. Any repair or replacement under this warranty does not constitute an extension of the original warranty for any period of the appliance or for any component or part thereof. Parts to be replaced under this warranty will be repaired or replaced at the option of Wood Stone with new or functionally operative parts. The liability of Wood Stone on any claim of any kind, including claims based on warranty, expressed or implied, contract, negligence, strict liability or any other theories shall be solely and exclusively the repair or replacement of the product as stated herein, and such liability shall not include, and purchaser specifically renounces any rights to recover, special, incidental, consequential or other damages of any kind whatsoever, including, but not limited to, injuries to persons or damage to property, loss of profits or anticipated profits, or loss of use of the product.

TO SECURE WARRANTY SERVICE

If you claim a defect covered by this Limited Warranty, contact:

Wood Stone Corporation, Attn: Service Department, 1801 W. Bakerview Rd., Bellingham, WA 98226 USA
Phone 1.800.988.8103 or 1.360.650.1111

This page left intentionally blank.

This page left intentionally blank.



WOOD STONE CORPORATION

1801 W. Bakerview Rd.
Bellingham, WA 98226 USA

Toll Free 800.988.8103

Tel 360.650.1111

Fax 360.650.1166

www.woodstone-corp.com

An ongoing program of product improvement may require us to change specifications without notice.