



WS-GFT-35-Round Tandoor model shown.

Job Name	
Model	WS-GFT-35
Item#	

FEATURES

- Cooks like Clay
- Long Lifespan
- Durable Ceramic Interior
- Consistent Reliable Heat
- 31" Model Also Available
- Round and Square Shapes Available

The Wood Stone gas-fired Tandoor features a cooking chamber that uses the same ultra-strong, high-temperature ceramic technology that we utilize in our stone hearth ovens.

The unit is available in a round, square and octagonal shape. The ceramic cooking chamber has a 13-inch opening and is encased in an insulated, stainless steel cabinet. The Tandoor is topped with an attractive and durable quartz composite that simulates the look of black granite. The entire unit sits on heavy-duty casters and includes a Naan Hook, Naan Scraper and Skewers.

The gas burner uses a pilot safety valve, equipped with a Piezo-Electric ignition system. The heat output of the burner can be adjusted from its highest setting to completely turned off (or any setting in between) by turning the Flame Height Control Knob, which is conveniently located on the top of the unit.

The Tandoor comes with a lightweight, ventilated lid for faster heat-up and a Skewer Indexing Ring to support and position skewers. A removable drip/debris pan is located beneath the unit.

Wood Stone Tandoors can be configured to burn Natural Gas or Propane—this should be specified at the time of order. Restraint anchors for a flexible gas supply line restraining cable are located beneath the unit.

The unit may be ordered with a caster riser assembly to increase the height of the Tandoor to 36 inches, to enable easy installation into a cooking suite.

Wood Stone 35" Tandoors arrive completely assembled, ETL Listed, ready to install and are made in the USA. Information about custom finishes, tools and accessories can be found online at: woodstone-corp.com.



t. 360.650.1111
tf. 800.988.8103
f. 360.650.1166

Wood Stone Corporation
1801 W. Bakerview Rd.
Bellingham, WA 98226 USA
info@woodstone-corp.com
woodstone-corp.com

REVISED: SPRING 2017, r04

An ongoing program of product improvement may require us to change specifications without notice.





TANDOOR 35"

GAS-FIRED TANDOOR • WS-GFT-35

PLAN VIEWS

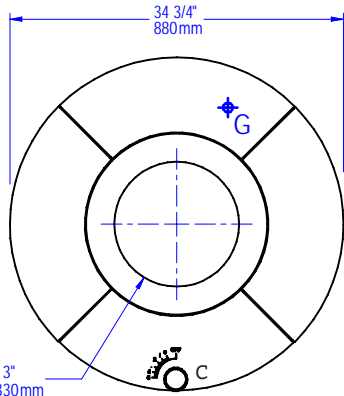

ROUND

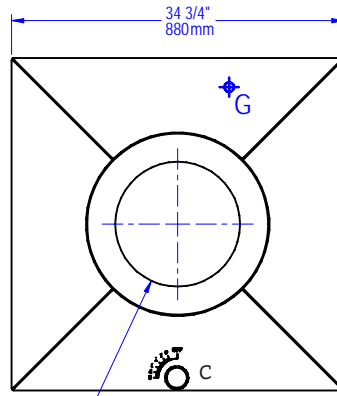

SQUARE

B	Removable Lid
C	Flame Height Control Knob
D	Removable Drip Tray
G	Gas Connection
	Must Be Left Removable for Service

FRONT VIEW

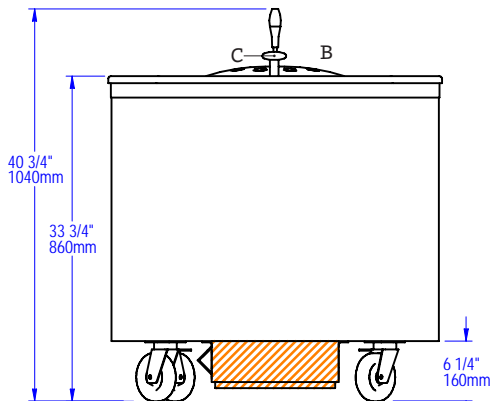

ROUND

SIDE VIEW

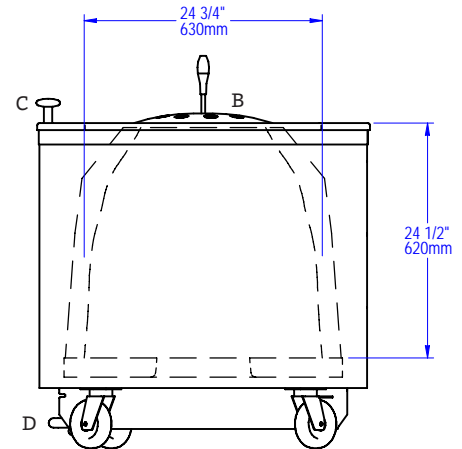

ROUND

UTILITIES SPECIFICATIONS

GAS
 1/2 inch gas inlet (FNPT)
 40,000 BTU/hr - Natural Gas (NG)
 OR
 40,000 BTU/hr - Propane (LP)

Note: Gas type must be specified at time of order.

VENTING INFORMATION

The Tandoor 35" must be vented with a Listed Type 1 exhaust hood, or one constructed in accordance with NFPA 96 and all relevant local and national codes. The oven must be vented in accordance with all relevant local and national codes, and in a manner acceptable to the authority having jurisdiction.

Ship Weight: 950 lbs / 431 kg



t. 360.650.1111
 tf. 800.988.8103
 f. 360.650.1166

Wood Stone Corporation
 1801 W. Bakerview Rd.
 Bellingham, WA 98226 USA
info@woodstone-corp.com
woodstone-corp.com

REVISED: SPRING 2017, r04

An ongoing program of product improvement may require us to change specifications without notice.

