



Job Name

Model

WS-GPL-3636-CT01

Item#

A high performance alternative to a standard flat top griddle, the Wood Stone Gas Plancha brings the power and caramelization of a gas charbroiler to a direct contact cooking surface. The highly engineered Gas Plancha delivers heat when and where it is needed with three thermostatically controlled and individually adjustable zones. This allows the Wood Stone Gas Plancha to support a range of cooking temperatures simultaneously.

The 3/4-inch thick smooth steel cooking surface is heated by three 28,300 BTU/hr burners. The Gas Plancha utilizes an amazingly responsive proprietary control system developed by Wood Stone, which provides uniform, consistent temperature control across the entire cook surface. Heat-recovery is fast, even under the most demanding loads.

The surface of the Gas Plancha can be used like a griddle as a direct contact cooking surface for searing or sautéing. With a temperature range from 150° F to 650° F, it's well suited to a wide variety of culinary applications with higher temperature ranges, allowing you to achieve the color and flavor of a chargrill.

The Gas Plancha features a small footprint that measures 36 inches x 36 inches with a 36-inch x 24-inch cooking surface. Supported by four legs, it is intended for installation on a suitable countertop or on the optional stand with front locking casters, available from Wood Stone.

The Gas Plancha must be vented with a Listed Type 1 exhaust hood, or one constructed in accordance with NFPA 96 and all relevant local and national codes.

The Gas Plancha arrives completely assembled, ready to install, and is made in the USA.

Note: At this time, this product is only available in North America.

## FEATURES

- Three Heat Zones
- Temperature Range of 150° F to 650° F
- Stainless Steel Backsplash
- Removable Drip Tray
- Optional Stand with Casters Available
- 48" (4-Zone) and 24" (2-Zone) Models Available



WS-GPL-3636-CT01 with optional stand shown.



t. 360.650.1111  
tf. 800.988.8103  
f. 360.650.1166

Wood Stone Corporation  
1801 W. Bakerview Rd.  
Bellingham, WA 98226 USA  
[info@woodstone-corp.com](mailto:info@woodstone-corp.com)  
[woodstone-corp.com](http://woodstone-corp.com)

REVISED: FALL 2017, r02

An ongoing program of product improvement may require us to change specifications without notice.



# GAS PLANCHA 36"

HIGH-TEMPERATURE GRIDDLE • WS-GPL-3636-CT01

PLAN VIEW

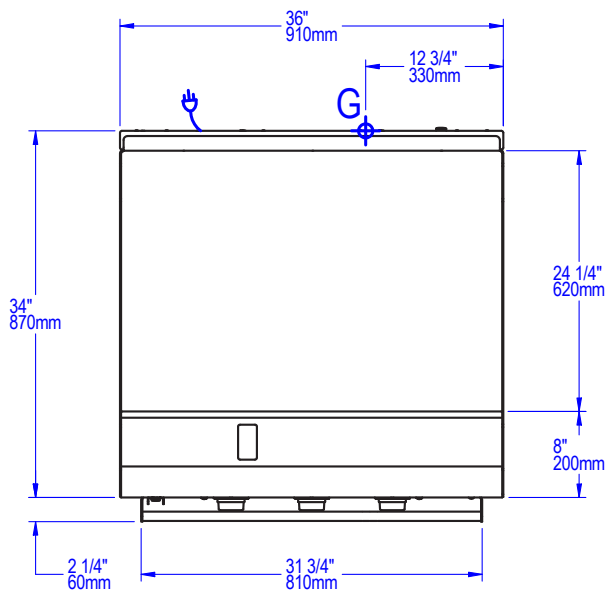

SIDE VIEW W/ OPTIONAL STAND

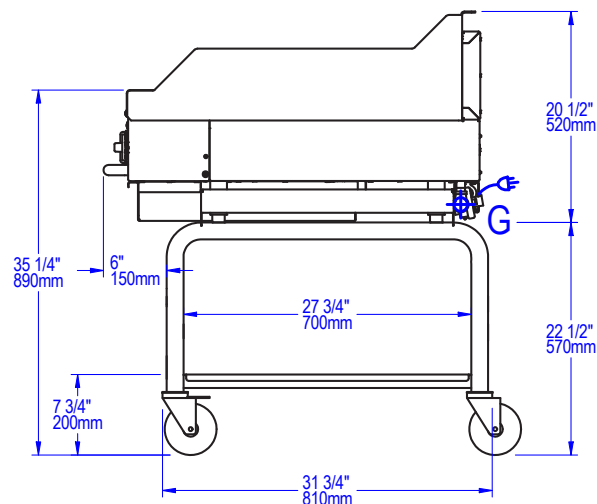

FRONT VIEW

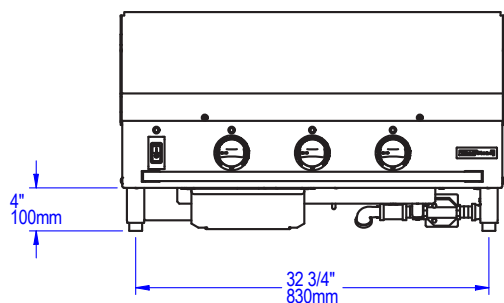

SIDE VIEW

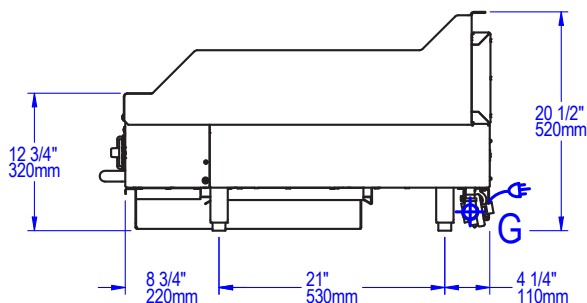

UTILITIES SPECIFICATIONS

**GAS**  
 3/4 inch gas inlet (FNPT)  
 85,000 BTU/hr - Natural Gas (NG)  
 OR  
 85,000 BTU/hr - Propane (LP)  
**Maximum gas inlet pressure:**  
 1/2 psi (14 inches W.C.)

**ELECTRICAL**  
 120 VAC, 0.6 A, 50/60 Hz, 1 Phase  
 Equipped with a NEMA 5-15P plug  
 for use with a standard 120 VAC,  
 15 A or 20 A outlet.  
 Refer to data plate when installing.

VENTING INFORMATION

The Wood Stone Gas Plancha must be vented with a Listed Type 1 exhaust hood, or one constructed in accordance with NFPA 96 and all relevant local and national codes. This appliance must be vented in accordance with all relevant local and national codes, and in a manner acceptable to the authority having jurisdiction.

**Unit Ship Weight: 490 lbs / 222 kg • w/ stand: 570 lbs / 259 kg**



t. 360.650.1111  
 tf. 800.988.8103  
 f. 360.650.1166

Wood Stone Corporation  
 1801 W. Bakerview Rd.  
 Bellingham, WA 98226 USA  
[info@woodstone-corp.com](mailto:info@woodstone-corp.com)  
[woodstone-corp.com](http://woodstone-corp.com)

REVISED: FALL 2017, r02

An ongoing program of product improvement may require us to change specifications without notice.

