



WS-BL-4343-RFG-LR model shown.

Job Name	
Model	WS-BL-(4343, 4355, 4836)-RFG-LR
Item#	

The Dual Burner 4343, 4355 and 4836 Bistro ovens feature a door opening 24 inches wide x 7.5 inches high. In the 4343 and 4355 Bistros, the cooking area is 26 inches wide x 34 or 46 inches deep, resulting in a 6- or 8.3-square-foot cooking surface respectively. The cooking area of the 4836 Bistro is 29 inches wide x 26.5 inches deep, resulting in a 5.4-square-foot cooking surface. All models feature a stainless steel mantle at the hearth.

Originally designed as high production flatbread ovens, the Dual Burner Bistros are also well suited for many other stone hearth cooking applications. The ovens feature two powerful, independently adjustable gas-fired radiant burners located on each side of the cooking chamber. Additionally, a burner disable switch allows operation with only one burner, further increasing their flexibility.

A tensioned steel exoskeleton surrounding the hearth and dome perimeters ensures structural integrity and longevity. Wrapped in spun ceramic fiber insulation and requiring only a 1-inch side clearance to combustibles, the monolithic 3-inch thick cast-ceramic hearths and monolithic 3-inch thick domes rest on painted black steel stands. The upper halves of the ovens are enclosed with stainless steel and the lower halves in a black painted finish.

The oven arrives completely assembled. However, using the optional Lifting System, the oven can be partially disassembled to fit through a 32-inch doorway—see the Installation and Operation Manual for details. It is ETL Listed, ready to install and is made in the USA.

Information about custom finishes, tools and accessories can be found online at: woodstone-corp.com.

HEARTH CAPACITY

	4343	4355	4836
6" pitas:	15	21	9
7" pitas:	12	15	9
9" pitas:	6	8	4
8" pizzas:	8	9-12	8
10" pizzas:	6	9	6
12" pizzas:	4	6	4

For pitas, assuming 90-second cook times, the approximate maximum hourly production capacity can be calculated by multiplying the above numbers by 40.

For pizza, assuming 5-minute cook times, the approximate maximum hourly production capacity can be calculated by multiplying the above numbers by 12. Cook times will also vary depending on "style" of pizza.

FEATURES

- Compact Footprint
- Visible Flame
- Low to Medium Production
- High-Temp Cooking
- 90 Second Pitas
- 3-5 Minute Pizzas



t. 360.650.1111
tf. 800.988.8103
f. 360.650.1166

Wood Stone Corporation
1801 W. Bakerview Rd.
Bellingham, WA 98226 USA
info@woodstone-corp.com
woodstone-corp.com

REVISED: SPRING 2017

An ongoing program of product improvement may require us to change specifications without notice.





PITA BREAD OVEN

DUAL BURNER BISTRO • WS-BL-(4343, 4355, 4836)-RFG-LR

Model	W	D
4343	42.5"	42.25"
4355	42.5"	54.25"
4836	47.75"	35.25"

PLAN VIEW

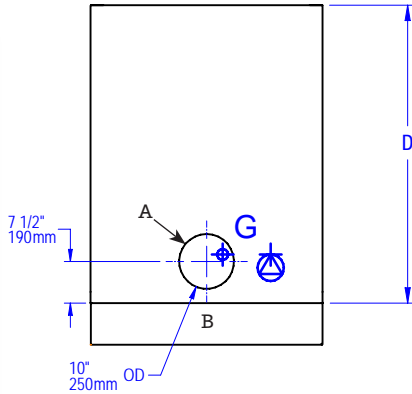

REAR VIEW

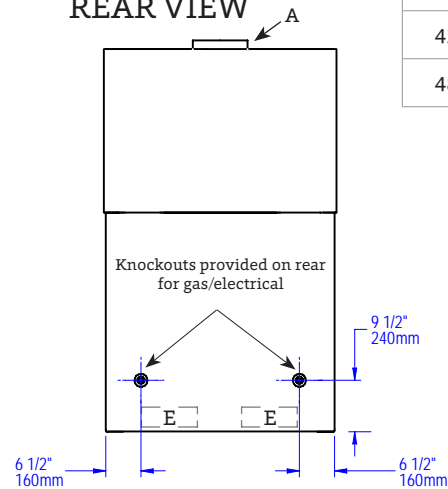

FRONT VIEW

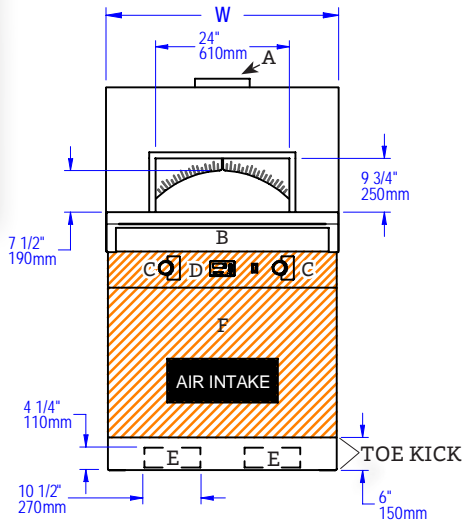

SIDE VIEW

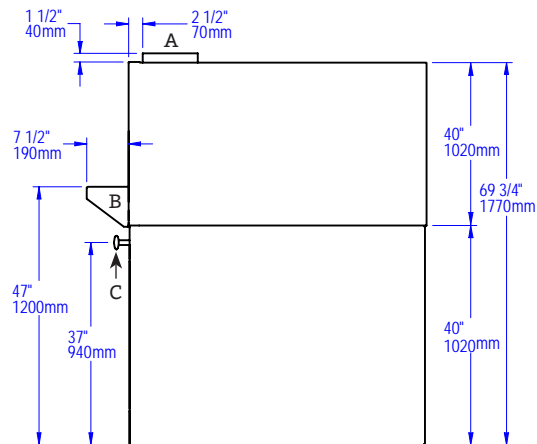

A	Flue Collar
B	Mantle
C	Flame Height Control Knob
D	Digital Controller
E	Forklift Pockets
	Electrical Connection
	Gas Connection
F	Service Panel or Optional Storage Box
	Must Be Left Removable for Service
	AIR INTAKE: Do Not Facade or Cover Over

UTILITIES SPECIFICATIONS

GAS
 3/4 inch gas inlet (FNPT)
4343 & 4836:
 105,000 BTU/hr - Natural Gas (NG)
 100,000 BTU/hr - Propane (LP)
4355:
 151,000 BTU/hr - Natural Gas (NG)
 151,000 BTU/hr - Propane (LP)
Note: Gas type must be specified at time of order.

ELECTRICAL
 120 VAC, 2 A, 50/60 Hz
 All utility connections made on the back of the oven control box. Remove front panel for access; use rear utility knockouts (provided) to route gas and electrical supplies.

VENTING INFORMATION

The Dual Burner Bistro has a 10-inch O.D. flue collar and can be direct connected to a power-ventilated, grease-rated chimney or can be vented with a Listed Type 1 exhaust hood, or one constructed in accordance with NFPA 96 and all relevant local and national codes. The oven must be vented in accordance with all relevant local and national codes, and in a manner acceptable to the authority having jurisdiction.

Ship Weight: 4343/4836: 2,100 lbs/953 kg • 4355: 2,500 lbs/1134 kg



t. 360.650.1111
 tf. 800.988.8103
 f. 360.650.1166

Wood Stone Corporation
 1801 W. Bakerview Rd.
 Bellingham, WA 98226 USA
info@woodstone-corp.com
woodstone-corp.com

REVISED: SPRING 2017

An ongoing program of product improvement may require us to change specifications without notice.

