

# Installation and Operation Manual



## **COAL-FIRED OVEN**

Stone Hearth Speciality Oven

---

*Gas/Coal Combination Models*

---

**FIRE DECK 9690** WS-FD-9690-CL

**FIRE DECK 11275** WS-FD-11275-CL

**FIRE DECK 11290** WS-FD-11290-CL

**Wood Stone**

**WOOD STONE CORPORATION**

1801 W. Bakerview Rd.  
Bellingham, WA 98226 USA

Toll Free 800.988.8103

Tel 360.650.1111

Fax 360.650.1166



**TABLE OF CONTENTS**

Fire Deck Coal-Fired Ovens . . . . . 3  
Cautions & Warnings . . . . . 4  
FD-9690-CL Specifications . . . . . 6  
FD-11275-CL Specifications . . . . . 7  
FD-11290-CL Specifications . . . . . 8  
Unloading & Moving the Oven . . . . . 9  
Caster Removal. . . . . 10  
Toe Kick Installation . . . . . 11  
Installation Clearances . . . . . 12  
Venting . . . . . 14  
Wood Stone Hoods. . . . . 16  
Gas Specifications . . . . . 18  
Gas / Electrical Specifications . . . . . 19  
Controller . . . . . 20  
Initial Start-Up. . . . . 21  
Daily Oven Operation . . . . . 22  
Use of Coal Overview . . . . . 23  
Daily Maintenance . . . . . 28  
Periodic Thermal Cleaning . . . . . 29  
Troubleshooting. . . . . 30  
Electrical Diagrams . . . . . 31  
Limited Warranty . . . . . 35



**INSTALLATION AND OPERATION MANUAL FOR THE  
WOOD STONE FIRE DECK COAL-FIRED OVEN**

**STONE HEARTH COOKING EQUIPMENT**

**FIRE DECK COAL-FIRED OVEN**

**WS-FD-9690-(L,R,LL,RR)-IR-CL,**

**WS-FD-11290-(L,R,LL,RR) CL AND**

**WS-FD-11275-(L,R,LL,RR)-IR-CL**

**ADDITIONAL MANUAL COPIES AVAILABLE UPON REQUEST**



Shown: Model FD-9690-LL-IR-CL

**INSTALLATION AND OPERATION MANUAL FOR THE  
WOOD STONE FIRE DECK OVEN****STONE HEARTH COOKING EQUIPMENT****WS-FD-9690, WS-FD-11275 AND WS-FD-11290 MODELS EQUIPPED FOR COAL BURNING****RETAIN THIS MANUAL FOR FUTURE REFERENCE**Additional copies of this manual at [woodstone-corp.com](http://woodstone-corp.com).

For prompt responses to service/maintenance questions, call us at @ 1-800-988-8103.

**READ ALL INSTRUCTIONS BEFORE INSTALLING AND USING THIS APPLIANCE**

Please read this entire manual before you install the oven. Failure to follow instructions may result in property damage, bodily injury or even death. Contact your local building or fire officials about restrictions and installation inspection in your area.

IF THIS OVEN IS NOT PROPERLY INSTALLED A FIRE MAY RESULT. TO REDUCE THE RISK OF FIRE, FOLLOW THESE INSTALLATION INSTRUCTIONS. A MAJOR CAUSE OF OVEN RELATED FIRES IS FAILURE TO MAINTAIN REQUIRED CLEARANCES (AIR SPACES) TO COMBUSTIBLE MATERIALS. IT IS OF THE UTMOST IMPORTANCE THAT THIS OVEN BE INSTALLED ONLY IN ACCORDANCE WITH THESE INSTRUCTIONS.

**WARNING:** Improper installation, adjustment, alteration, service or maintenance can cause property damage, injury or death. Read the installation, operation and maintenance instructions thoroughly before installing or servicing this equipment.

**AVERTISSEMENT:** L'installation, le réglage, la modification, la réparation ou l'entretien incorrect de cet appareil peut causer des dommages matériels, des blessures ou la mort. Lire attentivement les instructions d'installation, de fonctionnement et d'entretien avant de procéder à son installation ou entretien.

COAL FUEL - TO ENSURE CLEANEST EMISSIONS POSSIBLE, USE ONLY **ANTHRACITE COAL**. MANY VARIETIES OF COAL CONTAIN CHEMICAL IMPURITIES THAT CAN DAMAGE THE OVEN CERAMIC. USING **ANTHRACITE COAL** MINIMIZES THE CHANCE OF CHEMICAL DAMAGE TO THE OVEN CERAMIC. USE OF ANY COAL OTHER THAN **ANTHRACITE COAL** WILL VOID THE WARRANTY ON THE OVEN CERAMIC AND MAY LEAD TO INCREASED PARTICULATE AND OTHER EMISSIONS FROM THE OVEN WHEN COAL IS USED.



**IMPORTANT:** Consult your local gas supplier for a statement outlining a procedure to be followed in the event you smell gas. Post the statement in a prominent location.

**FOR YOUR SAFETY:** Do not store or use gasoline or other flammable vapors or liquids in the vicinity of this or any other appliance.

**ESURE DE SÉCURITÉ:** Ne pas entreposer ni utiliser de l'essence ni autres vapeurs ou liquides inflammables à proximité de cet appareil ou de tout autre appareil.

**Always keep the area under and around this appliance free and clear of any and all combustible materials.**

**CAUTION:** Never use gasoline, gasoline-type lantern fuel, kerosene, charcoal lighter fluid or similar liquids to start or freshen up a fire in this oven. Keep all such liquids well away from this oven when in use.

**CAUTION: DISCONNECT POWER TO THE OVEN BEFORE SERVICING OR CLEANING.**

It is recommended that this oven be installed, maintained and serviced by authorized professionals.

**WARNING:** In the event of a power failure, no attempt should be made to operate this appliance.

This product must be installed by a licensed plumber or gas fitter when installed within the Commonwealth of Massachusetts.

### SAVE THE INSTRUCTIONS

Wood Stone Fire Deck Coal-Fired ovens  
have been tested and approved by Intertek Testing Services and  
conform to ANSI Z83.11, UL 2162, UL 737 and CGA 2.17;  
are certified to CSA 1.8 and ULC S627;  
and to NSF/ANSI 4.



**Intertek**  
ANSI Z83.11  
CSA 1.8



**Intertek**  
ANSI/NSF 4



- Air intake: Do not facade or cover over
- Must be left removable for service

**Unit weight:**  
**10,000 lbs.**

**VERY IMPORTANT!**

Oven is shipped with casters which add 1-1/2". Height with casters to the top of the flue collar is 87-3/4". Once the oven is in place the casters must be removed.

Utility connections are made underneath the oven; they are shown on the plan view to illustrate geographic location only.

**Plan view**

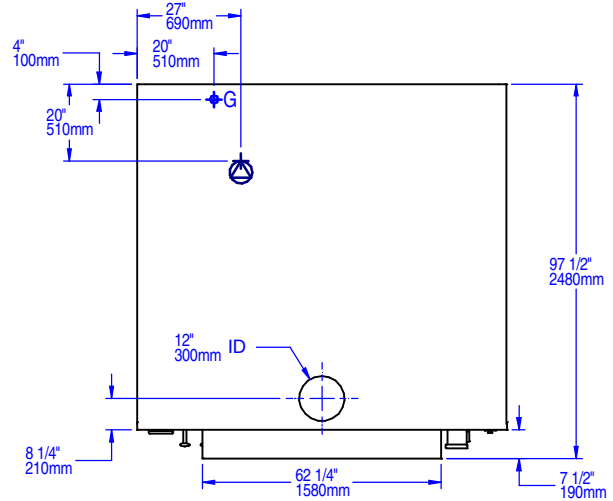

**Side view**

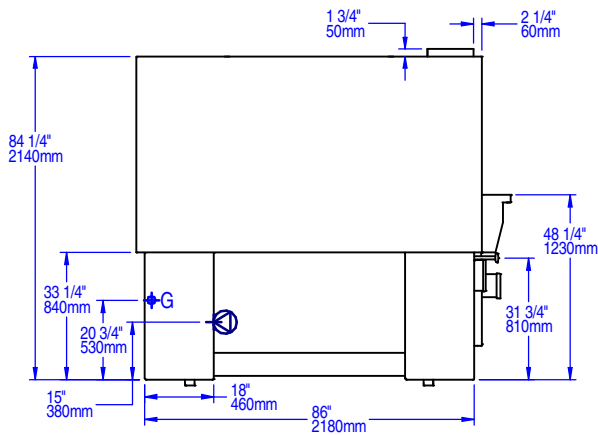

**Front view**

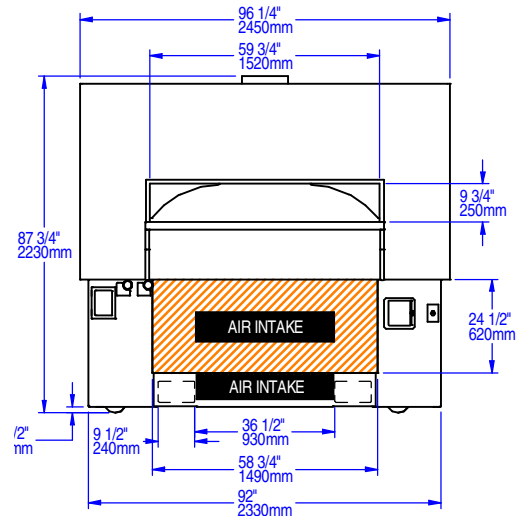

**UTILITY SPECIFICATIONS**

**Gas** Ⓜ

1" FNPT gas inlet  
347,000 BTU/hr Natural Gas (NG)  
**OR**  
369,000 BTU/hr Propane (LP)

**Decorative flame adds**

15,000 BTU/hr to total rated output

**Maximum gas inlet pressure:**

1/2 psi (14 inches W.C.)

**Electrical** Ⓜ

120 VAC, 4 A, 50/60 Hz  
Utility connections made on left side of oven as shown.

**Venting**

This oven may be vented with a Listed Type 1 exhaust hood **OR** directly connected at the 12-inch ID oven flue collar to a power-ventilated, grease-rated chimney **OR** an exhaust hood constructed in accordance with NFPA 96 and all relevant local and national codes. The oven must be vented in accordance with all relevant local and national codes, and in a manner acceptable to the authority having jurisdiction.

**IMPORTANT:** This model must be vented as a solid fuel appliance.



- Air intake: Do not facade or cover over
- Must be left removable for service

**Unit weight:  
9,500 lbs.**

**VERY IMPORTANT!**

Oven is shipped with casters which add 1-1/2". Height with casters to the top of the flue collar is 87-3/4". Once the oven is in place the casters must be removed.

Utility connections are made underneath the oven; they are shown on the plan view to illustrate geographic location only.

**Plan view**

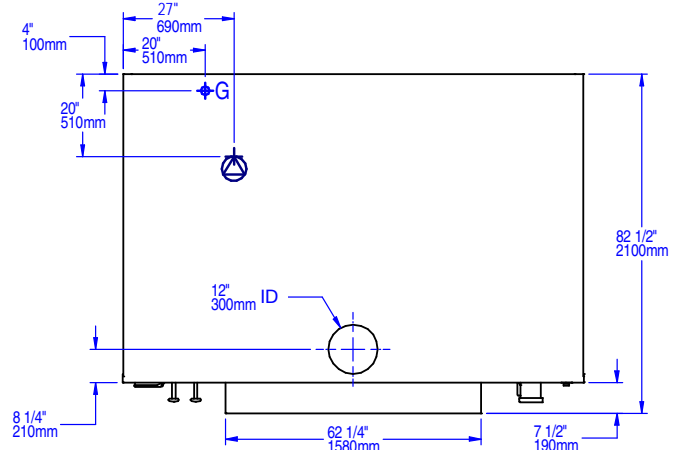

**Side view**

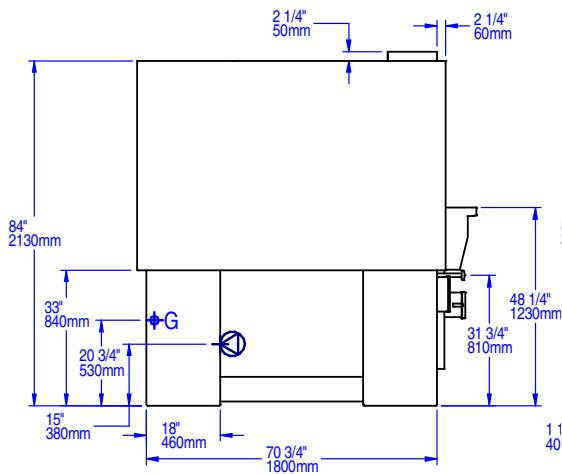

**Front view**

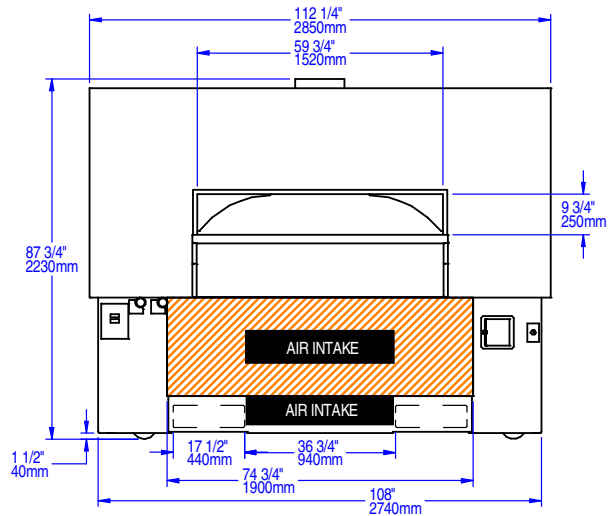

**UTILITIES REQUIRED**

**Gas** 1" FNPT gas inlet  
315,000 BTU/hr Natural Gas (NG)  
OR  
310,000 BTU/hr Propane (LP)

**Decorative flame adds**

15,000 BTU/hr to total rated output

**Maximum gas inlet pressure:**

1/2 psi (14 inches W.C.)

**Electrical**



120 VAC, 4 A, 50/60 Hz  
Utility connections made on back of oven

**Venting**

This oven may be vented with a Listed Type 1 exhaust hood **OR** directly connected at the 12-inch ID oven flue collar to a power-ventilated, grease-rated chimney **OR** an exhaust hood constructed in accordance with NFPA 96 and all relevant local and national codes. The oven must be vented in accordance with all relevant local and national codes, and in a manner acceptable to the authority having jurisdiction.

**IMPORTANT:** This model must be vented as a solid fuel appliance.



-  Air intake: Do not facade or cover over
-  Must be left removable for service

**Unit weight:**  
**11,500 lbs.**

**VERY IMPORTANT!**

Oven is shipped with casters which add 1-1/2". Height with casters to the top of the flue collar is 87-3/4". Once the oven is in place the casters must be removed.

Utility connections are made underneath the oven; they are shown on the plan view to illustrate geographic location only.

**Plan view**

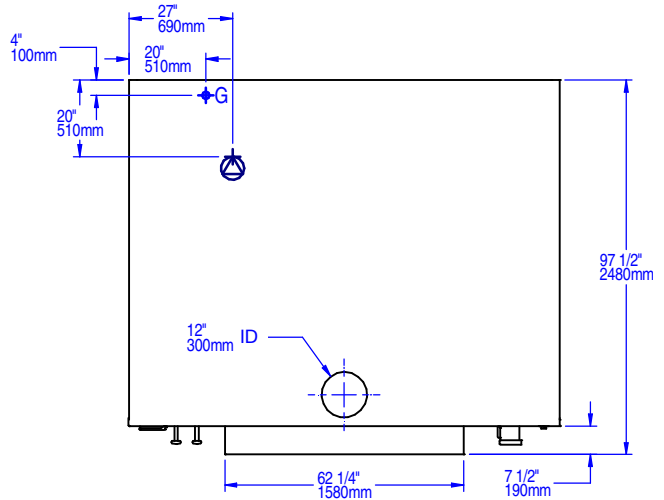

**Side view**

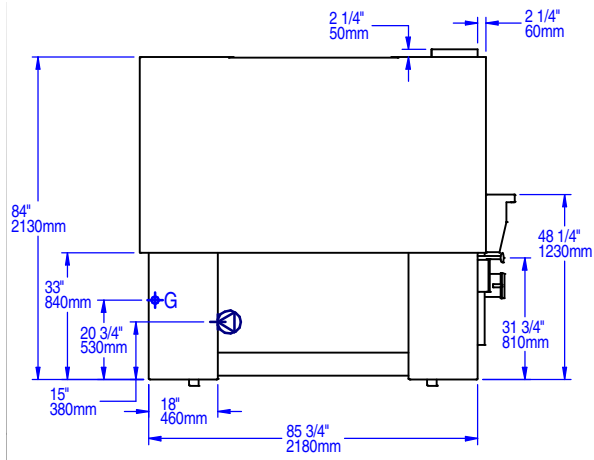

**Front view**

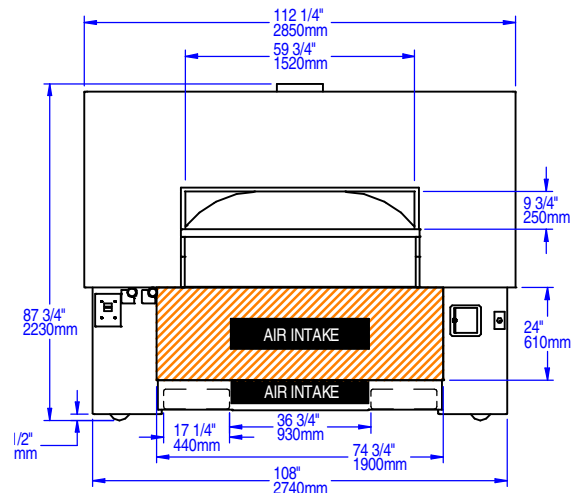

**UTILITIES REQUIRED**

**Gas**   
1" FNPT gas inlet  
347,000 BTU/hr Natural Gas (NG)  
**OR**  
369,000 BTU/hr Propane (LP)

**Decorative flame adds**  
15,000 BTU/hr to total rated output  
**Maximum gas inlet pressure:**  
1/2 psi (14 inches W.C.)

**Electrical**   
120 VAC, 4 A, 50/60 Hz  
Utility connections made on left side of oven as shown.

**Venting**

This oven may be vented with a Listed Type 1 exhaust hood **OR** directly connected at the 12-inch ID oven flue collar to a power-ventilated, grease-rated chimney **OR** an exhaust hood constructed in accordance with NFPA 96 and all relevant local and national codes. The oven must be vented in accordance with all relevant local and national codes, and in a manner acceptable to the authority having jurisdiction.

**IMPORTANT:** This model must be vented as a solid fuel appliance.





**WARNING: THE OVEN IS EXTREMELY TOP HEAVY.**

**DO NOT ATTEMPT TO MOVE THE OVEN WITHOUT THE PROPER EQUIPMENT AND EXPERIENCE. BE SAFE.**

**ALWAYS USE A FORKLIFT OR CRANE TO LIFT THIS OVEN.**

**DO NOT ATTEMPT TO USE A LEVER OF ANY TYPE TO RAISE THIS OVEN.**

**THE OVEN IS EQUIPPED WITH CASTERS AND CAN BE ROLLED ACROSS A SMOOTH, FLAT SURFACE ONLY.**

**Once the oven is in place, the casters must be removed. See the **CASTER REMOVAL** section of the manual.**

**DO NOT DROP THIS OVEN ABRUPTLY.**

Moving a Wood Stone Fire Deck oven can present challenges to even the most experienced riggers. Make sure to secure the proper equipment and make safety your first priority. Please don't hesitate to call the factory for technical support at **1-800-988-8103**.

### USING A FORKLIFT

Use a forklift with adequate fork lengths and lifting capacity. When using a forklift, always use the forklift pockets; lifting the oven any other way may result in damage. There are fork pockets only at the front and back of the oven. The oven may also be rolled across a smooth, flat surface on the temporary casters.

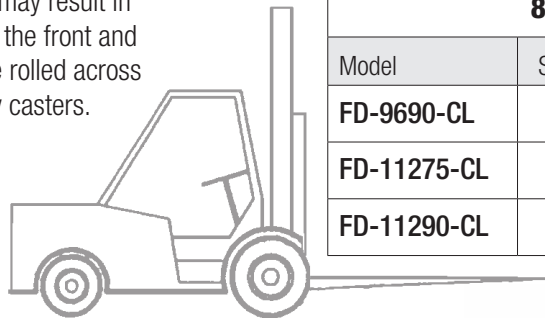

### ⚠ WARNING Minimum Required Forklift Capacities

#### 8' FORKS MINIMUM

Model	Shipping Weight	Lifting from Front or Rear
FD-9690-CL	10,000 lbs	24,000 lbs
FD-11275-CL	9,500 lbs	20,000 lbs
FD-11290-CL	11,500 lbs	26,000 lbs

### USING A CRANE

When craning a Wood Stone oven, use a Spreader Bar with a two-legged sling rigged on each end. Suitable lifting straps can be run through the fork lift pockets on the oven. The Spreader Bar should be of a sufficient length to keep the sling from contacting the oven and oriented as shown in (fig. 1).

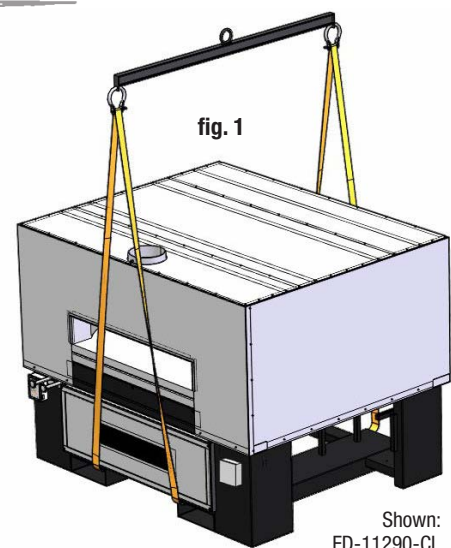

**IF YOU ARE PLANNING TO USE A CRANE TO UNLOAD THE OVEN, SPECIFY A FLATBED TRUCK DELIVERY!**

**NOTE:** Remove Oven Mantle before lifting the oven with a crane.

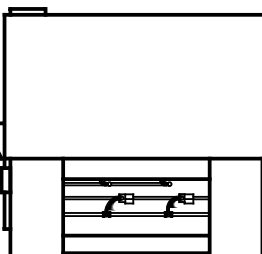

### DELIVERY NOTE

The customer will receive an Oven Shipping Notification when the oven leaves the Wood Stone factory. This will include a PRO# and a trucking company contact number. Wood Stone recommends that you confirm the delivery date/time with the trucking company before committing to heavy equipment and/or labor. Our goal is a smooth and safe delivery.



**TO MAINTAIN THE OVEN WARRANTY, SHIPPING CASTERS MUST BE REMOVED WHEN THE OVEN IS INSTALLED.**

The oven should be installed on a smooth, flat level surface. The weight of the oven is carried by the full perimeter of the oven stand. If it is necessary to shim the oven for leveling purposes, it is critical that the shim material be metal, and that the shims are installed in such a way that the full perimeter of the stand is solidly supported. Any gaps created by shimming between the oven and the floor must be sealed to prevent airflow issues beneath the oven. **Failure to solidly support the full perimeter of the oven stand can result in costly damage to the oven and will void the warranty.**

The floor design and construction must be adequate to handle the weight of the oven. Floor load information is available on the Wood Stone website.

**IMPORTANT: DO NOT JACK THE FRAME ANY HIGHER THAN THE MINIMUM NECESSARY TO REMOVE THE CASTER.**

Position a scissor jack under the oven frame near the caster to be removed.

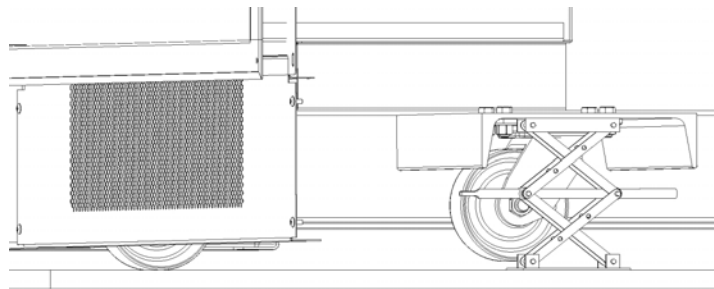

Use the jack to raise the caster so that it clears the floor slightly (1/4" should be sufficient). Remove the nuts and bolts retaining the caster to the oven frame.

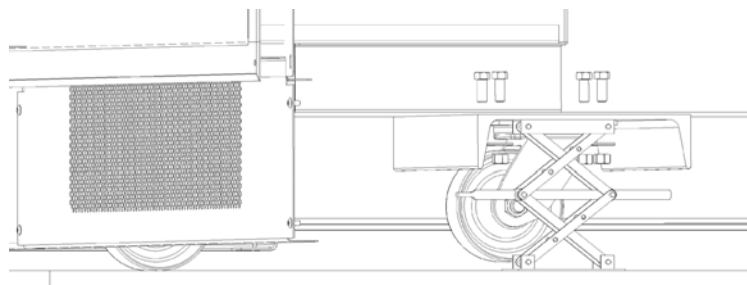

Rotate the caster in the direction of the fork legs to remove from oven, then lower the jack and proceed to the next caster and repeat procedure.

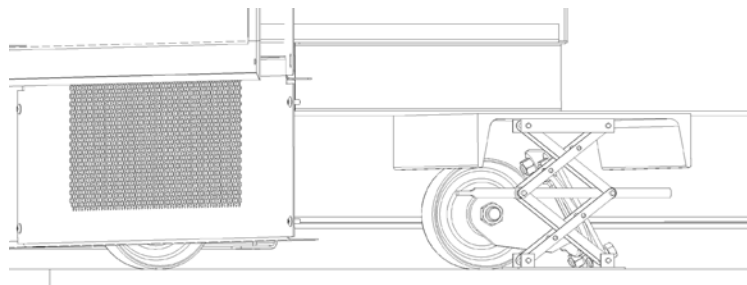

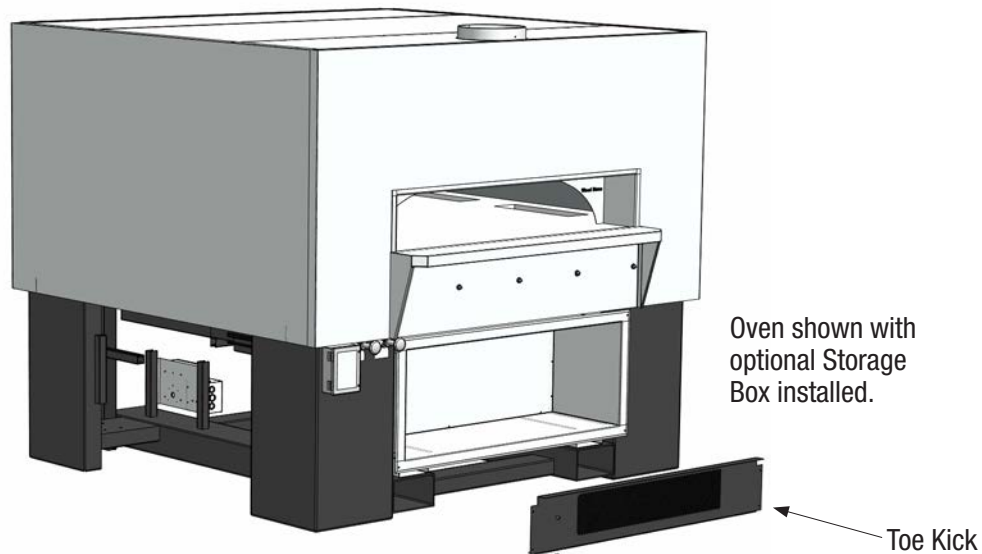
**TOE KICK INSTALLATION**

Once the oven is in place, the Toe Kick must be installed along the front of the oven using the screws provided. The area under the oven must be enclosed in order to prevent pests from entering this space and to prevent air flow issues which can detrimentally effect burner operation.

If the front of the oven is shipped facade ready, the Toe Kick will not be included. Pre-cut pieces of cement board will be shipped to cover the fork pockets. The pieces must be installed once the oven is in place.



**WARNING: Do not pack required air space (clearance) with insulation or other materials. When non-combustible building materials contact the body of the oven, the clearances to combustibles are transferred to those non-combustibles.**

1. The Wood Stone Fire Deck 9690, 11275 and 11290 ovens must have a minimum 1-inch clearance to combustibles from all sides, and 14-inch clearance to combustibles from the top (see figures below). Any construction 6 inches to either side of the doorway opening and above must be non-combustible. If building a facade that will contact the oven, use completely non-combustible materials\*. Please note that standard Drywall (or Sheetrock) is considered a combustible. If sealing an opening between the enclosure and the oven, use non-combustible building materials.
2. Install this oven on a non-combustible floor surface which extends at least 36 inches in front of, and 30 inches to either side of the doorway opening.
3. Any combustibles within 3 feet of the oven doorway should be protected in a manner acceptable to the authority having jurisdiction.

\* When non-combustible building materials contact the body of the oven, the respective clearances are transferred to those non-combustibles.

Front View

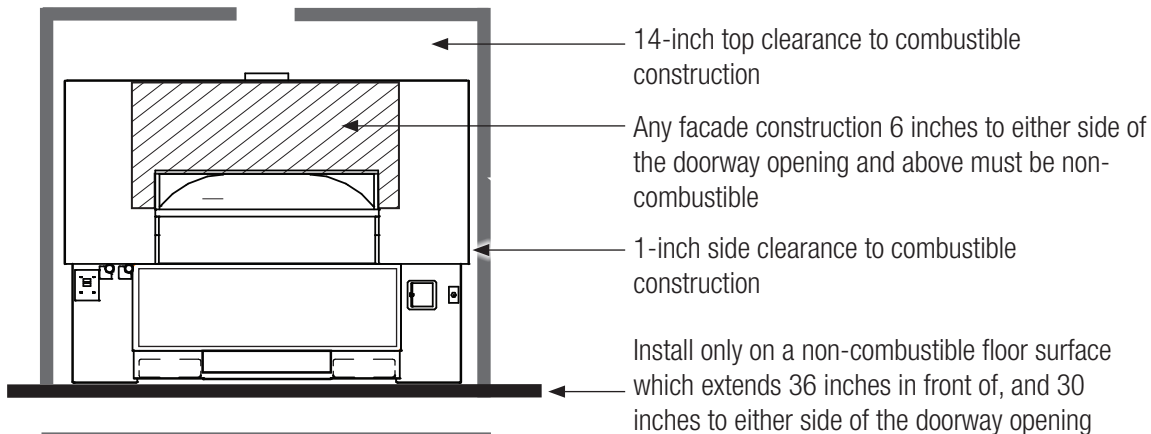

Plan View

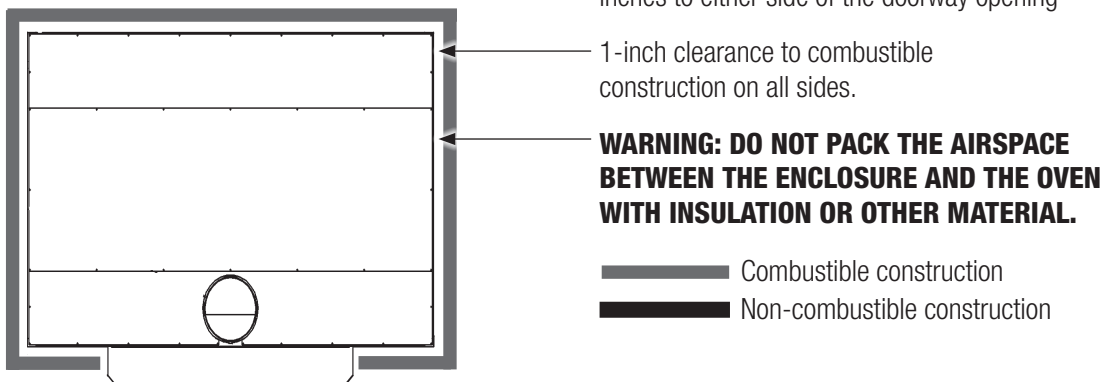



### INSTALLATION CLEARANCES OPERATIONAL ACCESS, SERVICE ACCESS AND CRITICAL AIR INTAKE VENTILATION

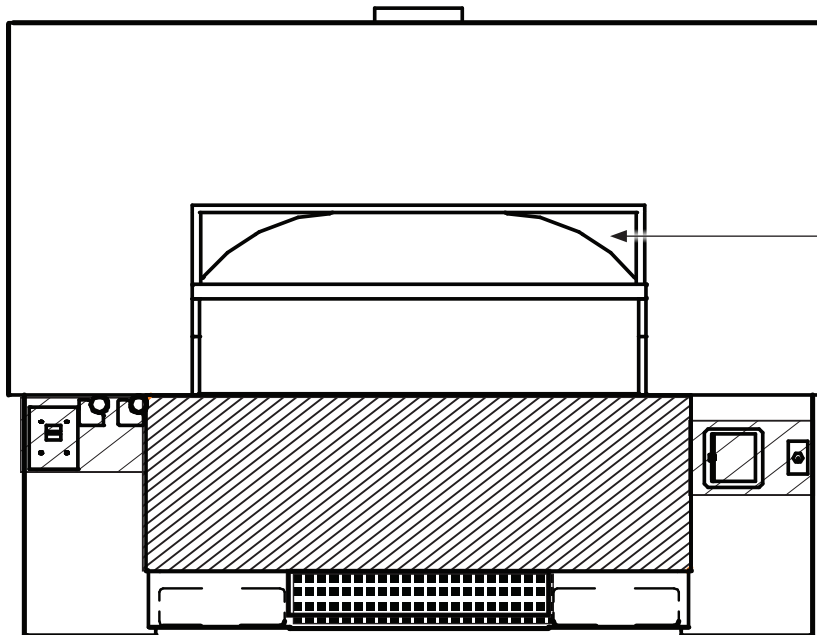

**Oven Arches**  
**DO NOT REMOVE**  
Removal will affect structural integrity, heat retention, operation and **void the Warranty**.

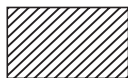

Area which **MUST** be left accessible for servicing the oven.

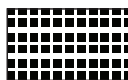

Area which **MUST** be left **UNOBSTRUCTED** to allow proper intake ventilation for the gas burners and/or the coal air plenum assembly.

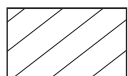

Areas which **MUST** be left open for normal operation of critical oven controls (Oven Controller, Flame Height Control Knob(s), Coal Blower Fan Control and Ash Chutes).

#### ABOUT FACADE MATERIALS

Fire Deck Series ovens can be finished with any non-combustible decorative material that can be easily affixed to the oven surface, including tile, stone or brick. It is always advisable to consult with the appropriate authority having jurisdiction before proceeding as there may be regulations regarding the suitability of various materials. Temperatures above the oven doorway can reach 200 °F. Select materials and adhesives suitable for that temperature.



It is never appropriate to use “B vent” in any part of an exhaust system connected to this oven. The venting system must be inspected and cleaned **at least monthly with solid fuel applications**. Wood Stone ovens with model numbers containing a suffix “-CL” must be vented as a solid fuel appliance (in accordance with NFPA 96). All combustion products and cooking vapors from the Wood Stone Fire Deck 9690 and the Fire Deck 11290 vent through a 12-inch O.D. flue collar located on the top of the oven, above the doorway.

**THE FOLLOWING ARE THE MANUFACTURER’S RECOMMENDATIONS FOR VENTING THE  
FIRE DECK 9690, 11275 AND 11290 OVENS WITH THE COAL BURNING OPTION.  
THERE ARE TWO OPTIONS SHOWN BELOW.**

1. A Listed building heating appliance chimney, also listed as a grease duct, connected directly to the oven flue collar and provided with a power ventilator listed for restaurant appliance exhaust and rated for operation at a minimum of 450 °F. Use a stack or curb mounted fan. Wood Stone does not recommend the use of an in-line fan. A field built grease duct installed and constructed according to the requirements spelled out in NFPA 96, the Standard for Ventilation Control and Fire Protection of Commercial Cooking Operations, or the International Mechanical Code may also be used.

A static pressure of -0.14 inches water column is necessary at the oven flue collar to ensure that gas temperatures do not exceed 450 °F. Use the fan inlet. This measurement may be taken by inserting the probe of the magnahelic gauge through the oven doorway, upwards to the oven flue collar. The cubic feet per minute (CFM) required to attain this static pressure will be approximately 750 CFM.

If using direct connect, it must be on its own duct system. Do not tie a duct direct connected to an oven into a duct system serving hoods due to balancing and potential code issues. Also note that if fire suppression is required, a Type 1 hood should be used due to the higher flue temperatures associated with the direct connect type of install.

**OR**

2. A Listed Type 1 exhaust hood or one that is constructed and installed in accordance with NFPA 96, and all relevant local and/or national codes. The hood must be connected to a 450 °F rated power ventilator listed for restaurant exhaust.

**REFER TO THE EXHAUST HOOD MANUFACTURER’S INSTRUCTIONS FOR INSPECTION, MAINTENANCE AND CLEANING RECOMMENDATIONS.**

**FIRE SUPPRESSION: COAL-FIRED OVENS**

Check with your local code officials to see if fire suppression is required in your area. If fire suppression is required, you must vent the oven using a Type 1 hood constructed and installed in accordance with NFPA 96. The fusible link in the hood must be rated at 450 °F minimum. Wood Stone offers Listed exhaust hoods for our ovens that are pre-piped for ANSUL R-102 fire suppression. All installations are subject to the approval of the local authority having jurisdiction.



**VERY IMPORTANT! WOOD STONE RECOMMENDS THAT YOU SUBMIT VENTING PLANS TO LOCAL CODE AUTHORITIES BEFORE PROCEEDING WITH INSTALLATION.**

**FIRE DECK VENTING**

Fire Deck model numbers containing a “-CL” must be vented in accordance with codes concerning solid fuel appliances (NFPA 96). Due to the dangers of creosote buildup and sparks entering the duct, these models must be vented separately from all other kitchen equipment and in a manner acceptable to the authority having jurisdiction. The Wood Stone customer support staff is available to answer any questions concerning installation and venting of the oven. Call 800.988.8103 for assistance and technical support.

Solid fuel exhaust contains creosote and other substances that accumulate in ducting, creating a risk of fire. The rate of accumulation will vary. Frequent, regularly scheduled, thorough flue cleaning is the best way to minimize the risk of flue fires. **Wood Stone recommends cleaning and inspection at least monthly on any ventilation system serving solid fuel equipment.**

**VENTILATION SYSTEM: CREOSOTE AND FLY ASH**

When solid fuel is burned slowly, it produces tar and other organic vapors, which combine with expelled moisture to form creosote. The creosote vapors condense in the relatively cool oven flue of a slow-burning fire. As a result, creosote residue accumulates in the duct. When ignited, this creosote makes an extremely hot fire. The duct serving this oven should be inspected at least twice a month during the first two months of operation to establish the rate of creosote (and fly ash—see below) buildup and the necessary cleaning schedule. If creosote or soot has accumulated, it should be removed to reduce the risk of a flue fire. The interior floor and dome of the oven do not require creosote or soot removal. The oven flue and exhaust system will require inspection and cleaning. The exhaust system should be inspected and cleaned per the manufacturer’s and or local code official’s recommendations.

While coal burning generally produces very little creosote, it does produce fly ash which will accumulate in the duct system. If allowed to accumulate the fly ash can block the air flow through the duct. It can also harden over time making removal much more difficult. Because of the acidic nature of the fly ash and the combustion products produced from coal burning, the entire duct system must be cleaned and inspected on a regular basis to ensure safe operation of the ventilation system.

**WOOD STONE RECOMMENDS THAT YOU SUBMIT YOUR VENTING PLANS TO THE AUTHORITY HAVING JURISDICTION BEFORE PROCEEDING WITH INSTALLATION OF ANY GAS AND/OR SOLID FUEL BURNING APPLIANCE.**





### FD-9690 / 11275 / 11290 HOOD - TOP VIEW

Wood Stone Hoods by Gaylord Specifications  
 Required CFM: 1050 CFM  
 Static Pressure: 0.80" W.C.  
 Duct Collar: 9" x 9" I.D.

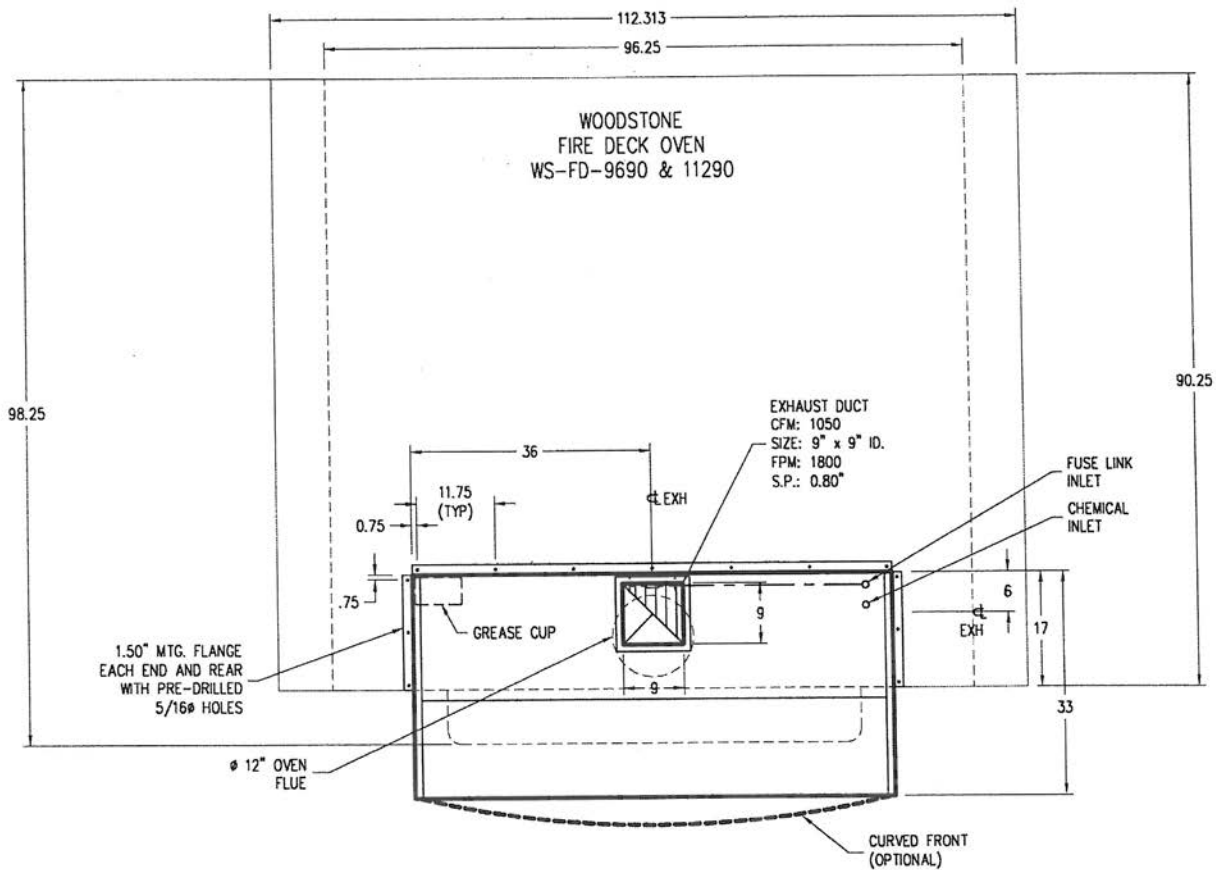





### FD-9690 / 11275 / 11290 HOOD - SIDE VIEW

**Wood Stone Hoods by Gaylord Specifications**  
**Required CFM: 1050 CFM**  
**Static Pressure: 0.80" W.C.**  
**Duct Collar: 9" x 9" I.D.**

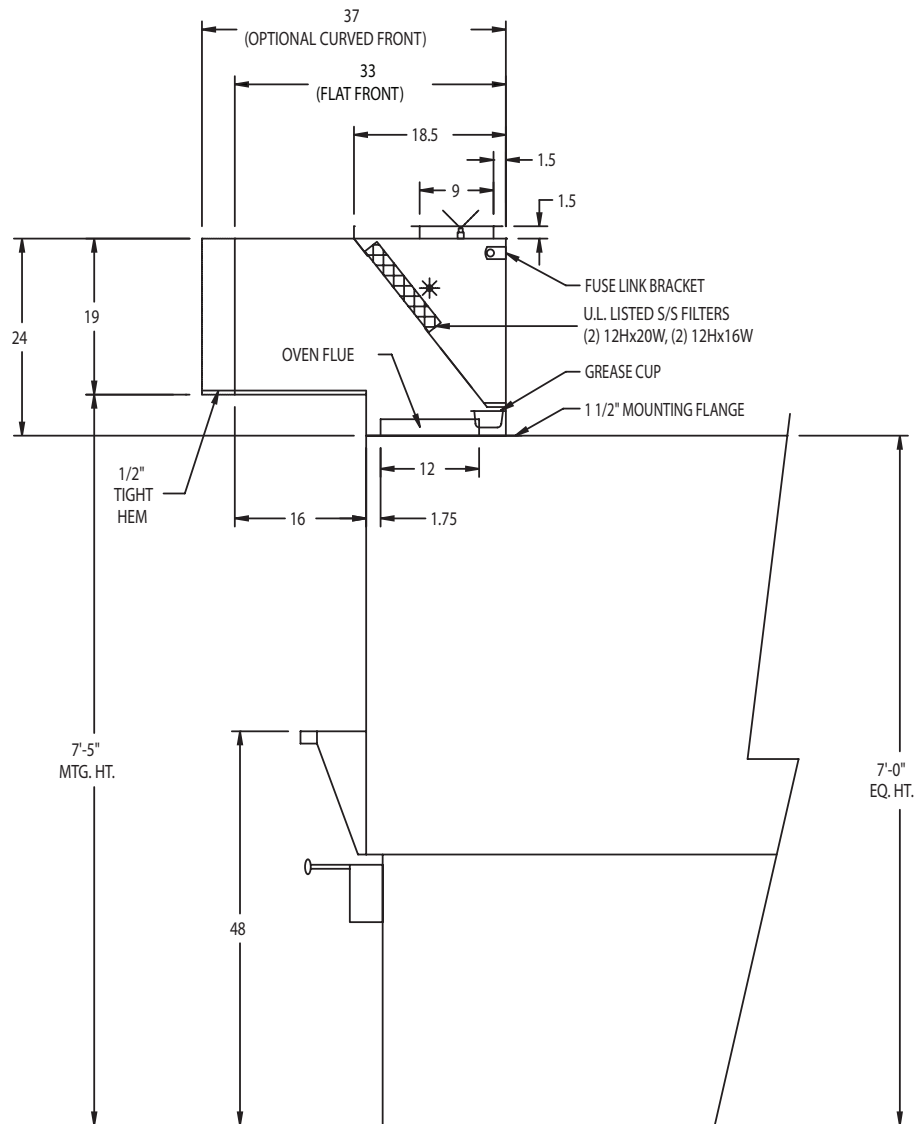



### FACTORY SPECIFIED VALVE OUTLET PRESSURES

Models <b>Note:</b> "L" or "R" in model number reflects the location of the radiant flame burner. Coal will burn on the opposite side.	Underfloor Infrared (IR) Burner	Radiant Flame Burner(s)	Natural Gas (NG)	Liquid Propane (LP)	Maximum Gas BTU/hr Input	Valve Outlet Pressure (W.C.)		
						SV-1	SV-2	SV-3
WS-FD-(9690 and 11290)-RFG-(L or R)-IR-CL (Coal)	1	1	NG		220,000	3.5"	4.6"	n/a
				LP	225,000	9.2"	9.5"	n/a
WS-FD-11275-RFG-(L or R)-IR-CL (Coal)	1	1	NG		187,500	3.5"	4.6"	n/a
				LP	177,500	9"	9.5"	n/a
WS-FD-(9690 and 11290)-RFG-(LL or RR)-IR-CL (Coal)	1	2	NG		347,000	3.5"	4.6"	4.6"
				LP	369,000	9.2"	9.5"	9.5"
WS-FD-11275-RFG-(LL or RR)-IR-CL (Coal)	1	2	NG		295,000	3.5"	4.6"	4.6"
				LP	282,500	9"	9.5"	9.5"

**This oven requires no modifications or adjustments for use at high altitudes.**

**The installation of this appliance must conform with local codes, or in the absence of local codes, with the National Fuel Gas Code, ANSI Z223.1 or The Natural Gas Installation Code CAN/CGA-B149.1 as applicable.**

SV-1 is the gas control valve that operates the Underfloor IR Burner. The manifold pressure is checked at the outlet port on the the individual gas valve.

SV-2 (and SV-3 / SV-4, etc., if equipped) are the gas control valve(s) that operate the interior Radiant Burner(s). The manifold pressure is checked at the outlet port on the the individual gas valve.

The burner manifold pressures have been adjusted and tested at the factory. A variety of factors can influence these pressures, so be sure to test the individual burner manifold pressures and adjust the valves as necessary to achieve the required pressures.

**NOTE:** The gas valves are shipped in the **ON** position.

### GAS CONNECTION

The Fire Deck 9690, Fire Deck 11275 and Fire Deck 11290 are equipped with a 1-inch FNPT gas connection. Have a licensed gas installer provide the hook-up and test all fittings and pipe connections for leaks. Use approved gas leak detectors (soap solutions or equivalent) over and around the fittings and pipe connections. **DO NOT USE A FLAME to test for leaks!**

All gas piping up to the oven must have a minimum inside diameter of 1", including all fittings and shut off valves, which should be of the full flow type.

Wood Stone recommends that the Fire Deck be equipped with a manual, individual shutoff valve, located between the oven and the main gas supply, and that this shutoff valve (supplied by others) be left readily accessible. Wood Stone also recommends that inspection and maintenance of the burners and gas piping connections of this appliance be performed at regularly scheduled intervals and only by professional gas appliance service agencies.



### Maximum inlet gas pressure must not exceed 14" W.C. (1/2 psi)

#### GAS INLET PRESSURE

For ovens running on natural gas, an inlet pressure of 7 to 10" WC is recommended to ensure optimum oven performance. Incoming gas pressure below this range will affect oven performance, the lower the pressure the greater the negative impact. If the gas supply pressure is greater than 14" W.C. (1/2 psi), an external regulator, supplied by others, is REQUIRED to lower the gas pressure to the acceptable range. Issues caused by low or high gas pressure are installation issues, and will not be covered under the Warranty.

For ovens running on LP, the recommended inlet pressure to ensure optimum oven performance is 10 to 12" W.C. Incoming gas pressure below this range will affect oven performance, the lower the pressure the greater the negative impact. If the gas supply pressure is greater than 14" W.C. (1/2 psi), an external regulator, supplied by others, is REQUIRED to lower the gas pressure to the acceptable range. Issues caused by low or high gas pressure are installation issues, and will not be covered under the Warranty.

For all installations, follow best practices for proper gas line pipe sizing for the line serving the oven. To insure proper operation, all gas piping and fittings leading up to the oven should have an inside diameter equal to or greater than that of the oven gas connection. Also make sure that a readily accessible shut off valve (supplied by others) is installed near the oven, and in accordance with all applicable codes. Shut off valves must be of the full-flow type, and not introduce any restriction into the gas line.

The connection to the oven should be hard-piped whenever feasible. If this is not possible, use a properly sized flexible connector approved for this application. When using a flexible connector make sure that its design does not present any reduction in pipe diameter or other restriction. Oven issues caused by improper pipe sizing, improper shut off valves, restrictive connectors, or any other deficiency in the gas supply design or installation will not be covered under the oven warranty.

#### GAS CODE LIMITATIONS

The installation of this appliance must conform with local codes, or in the absence of local codes, with the National Fuel Gas Code, ANSI Z223.1 or The Natural Gas Installation Code CAN/CGA-B149.1 as applicable.

The appliance and its individual shutoff valve (supplied by others) must be disconnected from the gas supply piping system during any pressure testing of that system at test pressures in excess of 1/2 psi (14" W.C.) (3.45 kPa).

The appliance must be isolated from the gas supply piping system by closing its individual manual shutoff valve (supplied by others) during any pressure testing of the gas supply piping system at test pressure, equal to or less than 1/2 psi (14" W.C.) (3.45 kPa).

#### ELECTRICAL

##### POWER CONNECTION TO THE OVEN

Provide a 120 VAC, 15 A circuit to the terminal strip, located in the transformer junction box located beneath the oven (**Note: These models are open beneath the oven**). The terminal strip is labeled L, N and G (Line, Neutral and Ground, respectively.)

Electrical diagrams are shown in the ELECTRICAL DIAGRAMS section of this manual. They can also be found beneath the oven on the transformer plate.

##### ELECTRICAL CODE LIMITATIONS

**Electrical Grounding:** This appliance must be electrically grounded in accordance with local codes, or in the absence of local codes, with the National Electrical code, ANSI/NFPA 70 or the Canadian Electrical Code, CSA C22.1 as applicable.



### CONTROLLER FUNCTIONS

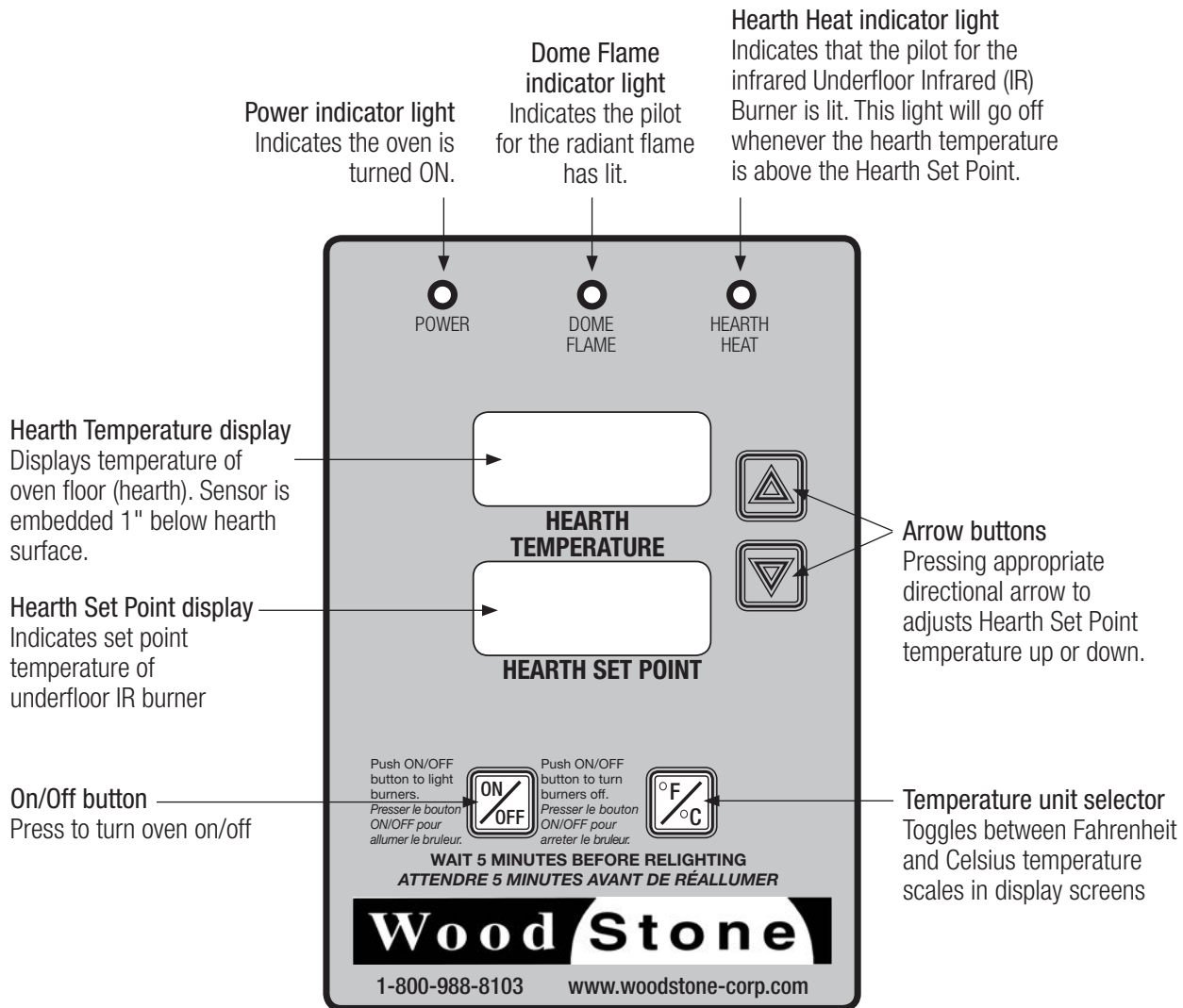



### INITIAL OVEN START-UP PROCEDURE

Your oven was cured at the factory. However, in the course of shipment, storage on-site, etc. the ceramic materials will have absorbed moisture. It is critical that the initial oven start-up procedure below be followed to ensure that this moisture is driven from the ceramic in a controlled fashion. This will minimize cracking and prevent damage to the oven that could otherwise occur by bringing the oven to temperature rapidly the first time it is used. This initial oven start-up procedure needs only be followed the first time the oven is fired and/or if the oven has not been used for an extended period of time.

#### BEFORE GETTING STARTED

1. Make sure the individual shutoff valve (supplied by others), between the oven and the main gas supply, is in the open position and that the line has been purged of air.
2. Make sure the Honeywell gas valves beneath the oven (SV-1, SV-2 and SV-3—depending on configuration) are in the ON position.
3. Make sure that the venting system has been tested and approved for operation and is on.

#### FIRST DAY

1. Push the ON/OFF button on the Controller touchpad. It may take a while for all of the air to be purged from the gas lines. As the pilot flames for the gas burners ignite and are sensed, the corresponding indicator lights will illuminate. The burners should come on shortly. For the first day start up on ovens equipped with the radiant dome flame burner, use the gas burners only to heat the oven. **Do not use coal.**
2. Leave the Hearth Set Point at the factory setting (100 °F).
3. Adjust the radiant flame to 50% (“3” on the Flame Height Index Scale) and allow the oven to run for a full day until the hearth temperature reaches 500 °F.
4. The oven is now ready for cooking.

**YOU MAY NOTICE THE OVEN SHEDDING SOME WATER FOR A COUPLE OF DAYS. THIS IS NORMAL AND YOU SHOULD NOT BE ALARMED.**

**NOTE:** Small “crazing” cracks will occur with normal heating and cooling. They will not effect the performance or durability of the oven. If cracks of 1/8-inch or more in width develop, contact Wood Stone for evaluation.

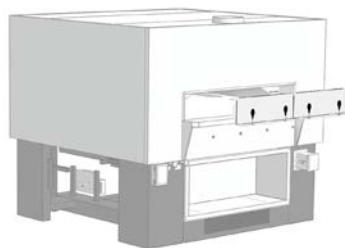

#### NIGHT HEAT RETENTION DOORS

**NOTE:** Never operate this oven with the (optional) stainless steel Night Heat Retention Door in place. This option is for heat retention **only**, and should only be used when the oven is turned OFF.



## GENERAL OVEN OPERATION

Your Wood Stone coal burning oven utilizes both coal and gas heat sources and is designed to perform at its best when both are used properly. We will first look at basic operation of the gas burners, followed by a detailed discussion pertaining to the coal fire.

### GAS BURNERS

**IMPORTANT:** If at any time you feel that the burners are not operating properly, turn the oven off and call WOOD STONE for service. Before servicing, disconnect the electrical supply at the breaker and turn off the gas supply at the appliance's individual gas shutoff valve. This oven uses electronic ignition systems for the gas burners. In the event of a power failure, no attempt should be made to operate the oven.

See the following page for an illustration of the oven Controller. See the USE OF COAL OVERVIEW section in the following pages for information regarding the use of coal in the oven.

### TURNING ON THE OVEN

- Press the ON/OFF button to start the oven.
- The radiant flame will ignite. This is the burner with the visible flame located in the cooking chamber. The infrared Underfloor Infrared (IR) Burner will ignite if the hearth temperature is below the Hearth Set Point to which the Controller is adjusted.

**Power Light:** Indicates the oven is turned ON.

**Dome Flame light:** Indicates the pilot for the radiant flame has lit.

**Hearth Heat Light:** Indicates that the pilot for the infrared Underfloor Infrared (IR) Burner is lit. This light will go off whenever the hearth temperature is above the Hearth Set Point.

### TURNING OFF THE GAS BURNERS

- Press the ON/OFF button on the Controller to turn the oven off. The burners and pilots will go out and the digital readout on the Controller will go blank. **Always wait 5 minutes before attempting to relight the oven.**

### ADJUSTING THE RADIANT (DOME) FLAME

- To adjust the radiant flame burner, turn the Flame Height Control Knob located near the Controller. The burner, together with the coal fire, are the primary heat sources for the oven. The radiant flame is always on whenever the Controller is turned on and can be adjusted to any flame height between the highest and lowest settings.

### ADJUSTING THE HEARTH SET POINT

- The Hearth Set Point controls the operation of the underfloor infrared burner. This thermostatically controlled burner is intended to act as an assist during heat-up, and to help maintain the desired hearth temperature. To adjust the Hearth Set Point, use the arrows to raise or lower the setting accordingly. When the Hearth Set Point is above the actual hearth temperature, the Underfloor Infrared (IR) Burner should activate, and the Heart Heat indicator Light will illuminate.

The stainless steel Night Heat Retention Doors are used to retain oven heat overnight. Never operate the oven with these doors in place.

**OVENS EQUIPPED FOR COAL BURNING**

Ovens with “-CL” in the model number are equipped to burn coal. These ovens are equipped with a blower and plenum beneath the oven that provides combustion air to the coal-fire through a grate installed in the oven deck. The coal fire must be built on this grate inside the cooking chamber of the oven. Use the blower control on the front of the oven to control the rate of air being supplied to the coal fire by the Coal Blower Fan. As the coal burns, ash and debris will drop through the grate down into the air plenum below. To remove accumulated ash, open the Ash Chute door on the front of the oven, and using the ash rake provided with the oven, rake the ash and debris into a suitable steel container. Store the ash container in a safe place until the ash has cooled and can be disposed of. **All coal burning ovens must be vented as solid fuel equipment!** See information below.

**USE COAL FUEL ONLY. DO NOT USE PRODUCTS NOT SPECIFIED FOR USE WITH THIS OVEN.**

**COAL FUEL: TO ENSURE CLEANEST EMISSIONS POSSIBLE, USE ONLY HIGH QUALITY ANTHRACITE COAL. MANY VARIETIES OF COAL CONTAIN CHEMICAL IMPURITIES THAT CAN DAMAGE THE OVEN CERAMIC. USING ANTHRACITE COAL MINIMIZES THE CHANCE OF CHEMICAL DAMAGE TO THE OVEN CERAMIC. USE OF ANY COAL OTHER THAN ANTHRACITE COAL WILL VOID THE WARRANTY ON THE OVEN CERAMIC AND MAY LEAD TO INCREASED PARTICULATE AND OTHER EMISSIONS FROM THE OVEN WHEN COAL IS USED.**

**CLEAN THE ASH CHUTE DAILY TO PREVENT BUILD UP OF ASH AND DEBRIS. FAILURE TO DO SO WILL RESULT IN DAMAGE TO THE BLOWER UNIT AND VOID YOUR WARRANTY.**

**DO NOT ATTEMPT TO USE THE RADIANT FLAME BURNER TO IGNITE THE COAL FIRE.**

**COAL SHOULD BE STORED AND HANDLED IN ACCORDANCE WITH THE RECOMMENDATIONS OUTLINED IN NFPA 96.**

The interior floor and dome of the oven do not require creosote or soot removal. The oven flue and exhaust system will require inspection and cleaning. The exhaust system should be inspected and cleaned per the manufacturer's and or local code official's recommendations.

Dispose of ash per the following: Place ashes into a metal container with a tight fitting lid. The closed container of ashes should be placed on a non-combustible floor or on the ground, well away from all combustible materials, pending final disposal. They should be retained in the closed container until all the cinders have thoroughly cooled. Ashes can then be disposed of safely.

If at any time you feel the gas components of the oven are not operating properly, turn the oven off, shut off the gas supply and call Wood Stone at 1.800.988.8103 to arrange for service.



A coal fire is much more challenging to start and is more difficult to manage than a wood fire or gas burner. Simply getting anthracite coal burning requires an ignition source in excess of 900 °F that is usually provided by a bed of burning charcoal. Dry wood by comparison burns more quickly and starts burning at around 450 °F. Coal has roughly twice the heat/energy potential of wood (13,000 BTU/hr per pound for coal versus roughly 6,500 BTU/hr per pound for wood) so accessing and managing its potential energy when and where you need it can be challenging.

Unlike a wood fire, a coal fire will not let you stir its fire or move it around without consequence. Balancing the open flame of a coal fire with the intensity of the coal bed becomes the daily challenge. If you load too much fuel, the intensity of the fire will melt metal along with your pizza. If you load too little fuel, you will find yourself starting all over to recapture the intense heat you lost by letting the coal fire burn too long without attention.

### **WHAT YOU NEED TO GET STARTED**

Safety glasses, solid fire starter, lump wood charcoal, **anthracite coal** (the only Wood Stone approved type of coal), 25 pound scale, large metal bowl, paper grocery bags, wood/coal cart, double compartment Ash Dolly, Ash Chute tool, in-line floor brush, natural fiber brush, utility peel, large pizza peels. **Never use a liquid-type fire starter or liquid fuel as a fire starter.**

### **COAL-FIRED OVEN OPERATIONAL GUIDELINES**

The typical desired hearth temperature for Wood Stone coal-fired ovens is 550–580 °F. **CAUTION:** Over firing the oven with coal may cause damage to the oven ceramics. If the oven deck temperature is above 850 °F, or flames exit the doorway or flue of the oven, you are over firing. Only use anthracite coal—see notes contained earlier in this manual.





**Note: In these instructions the term “coal” refers to anthracite coal. The term “charcoal” refers to wood lump charcoal.**

**END OF DAY**

1. Turn the oven Controller to OFF.
2. Turn the Coal Blower Fan to its lowest setting, NOT OFF. Running the fan on its lowest setting overnight will help extend the life of the Coal Grates.
3. Put the Night Heat Retention doors in place to help retain heat overnight.

**START OF DAY**

1. Remove Night Heat Retention doors.
2. Turn Coal Blower Fan off so fly ash is not blown around the oven.
3. Turn the radiant flame all the way up (heat-up flame).
4. To avoid overheating, during heat-up we recommend lowering your normal Hearth Set Point by 50 °F. In the most common scenario (550–580 °F) the Hearth Set Point becomes 500 °F.
5. Use the Ash Chute Tool to rake through the coal bed, pushing fly ash and small pieces of coal through the grate. Move any large pieces of burnt and semi-burnt coal onto the coal grate.
6. Using the Ash Chute Tool, pull yesterday’s fly ash out through the Ash Chute into the Ash Dolly.
7. Measure 5-10 lbs of charcoal and place on top of the previous day’s leftover pieces of coal.
8. Light two paraffin-type fire starters and place them beneath the larger pieces of charcoal.
9. Set the Coal Blower Fan to the high setting to speed the combustion of the charcoal.
10. When the charcoal is 50% ignited, (15–20 minutes), create an indentation on the top of the coal bed.
11. Place 10-20 lbs. of anthracite coal on top of the coal bed in the indentation created above. Leave the Coal Blower Fan set to high. **Note:** Load the coal on this live bed of lump charcoal while the charcoal still has lots of heat potential left (unburned portions) or the coal will not fully light. Load the coal when you see that the initial pile of lump charcoal has burned approximately to its halfway point.
12. After the hearth temperature reaches the desired daily baking temperature (550 °F), adjust the Hearth Set Point up to 550 °F.
13. Adjust the Coal Blower Fan speed to 5 (halfway point).
14. Adjust the radiant flame to 5-6 inches in height. This is approximately 3 on the Flame Height Index Scale.
15. Clean the oven hearth and you are ready for cooking. Add coal and manage the Coal Blower Fan speed as necessary throughout the day.

**DURING THE DAY**

- Turn the Coal Blower Fan to 10 during heat up, or any time you add fresh coal to the fire.
- Turn the Coal Blower Fan to 10 any time you are baking pizza.
- Turn the Coal Blower Fan to 5 after heat up and when not baking.
- Always pay attention to the amount of unspent coal, time of day and cycle of business so as to keep the oven properly fueled. Keep in mind that it takes 20 to 30 minutes for newly loaded coal to fully ignite and begin generating heat.
- We recommend portioning coal into paper shopping bags in 10 pound increments to simplify temperature management. Anthracite coal has about 13,000 BTU/hr per pound, so a ten pound bag has a total of 130,000 BTU/hr.
- Most coal-fired operators bake 3–6 minute pizzas and bake at hearth temperatures between 500–600 °F, which equals around 900–1,000 °F degree dome temperature. Although these ovens can achieve higher temperatures, do not exceed 850 °F or damage may occur.
- Depending on desired cooking temperature, speed of bake and amount of production, add 10–20 pounds of coal every 1–2 hours.
- Adding coal and turning up the speed of the Coal Blower Fan will add energy to the chamber. It generally takes about 20–30 minutes to see a significant influence of adding coal and turning up the fan.
- Baking a lot of pizzas will take BTU/hr out of the chamber. Your gas burners and proper coal fire management will allow you to bake at a very consistent temperature.

This guide is a starting place. Your desired cooking temperature, cycle of business and hours of operation will dictate your particular operational procedures. If you have any questions, call us at 1.800.988.8103.

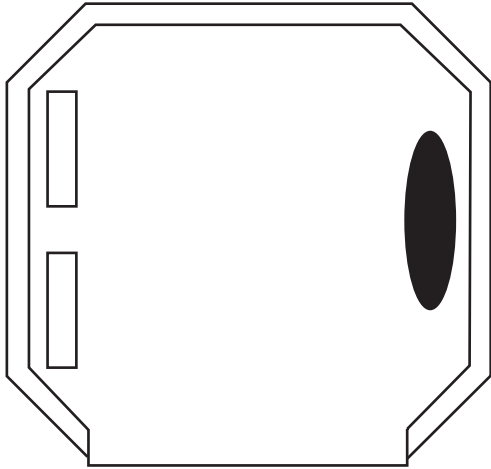

Coal fire is burned on side opposite the Radiant Burner, over the Coal Grates.

**Note:** Coal Grates are a consumable item—life will vary depending on oven temperature, hours of operation, fuel consumption, and proper use of the Coal Blower Fan (see below). It is expected grates will require replacement approximately every 4–6 months.

Replacement grates are available from the factory.

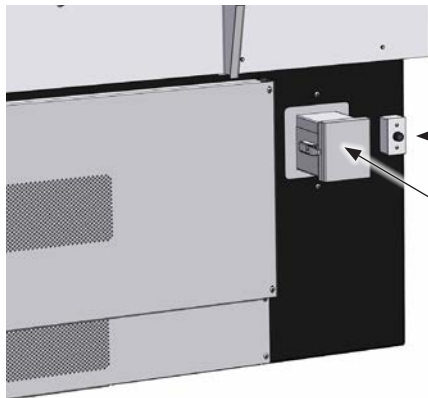

Coal Blower Fan Control

**Note:** Running the coal fan on its lowest setting overnight will help extend the life of the Coal Grates.

Ash Chute

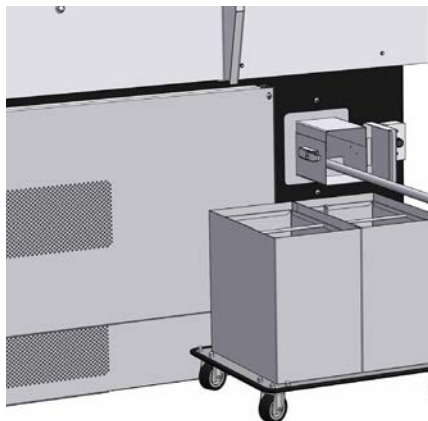

Removing ash from Ash Chute

Ash Chute Tool

Double Compartment Ash Dolly

**OVEN INTERIOR**

Wood Stone recommends the use of long-handled brushes for sweeping up surface debris that will accumulate on the floor of the oven during use. Use a natural fiber brush, always brushing away from the Radiant Burner well. For deeper cleaning, use a brass bristled brush. The oven floor can be then cleaned with a damp rag wrapped around the brush head.

Wood Stone offers an assortment of oven brushes available through your dealer. Specification sheets may be viewed on the Wood Stone website under Tools & Accessories.

**TAKE CARE NOT TO BRUSH DEBRIS INTO THE RADIANT FLAME BURNER(S).****OVEN EXTERIOR (DOORWAY AND MANTLE)**

All exterior stainless steel surfaces should be cleaned as necessary using an approved mild detergent, hot water and a soft cloth or sponge. Stubborn residues may be removed using a non-metallic scouring pad. When scouring stainless steel surfaces, scrub with the grain of the metal to prevent scratching.

**DO NOT POUR OR SPRAY LIQUIDS ONTO THE OVEN DECK OR INTO THE OVEN INTERIOR AS THIS CAN DAMAGE THE CERAMIC AND WILL VOID THE WARRANTY.****IMPORTANT: DO NOT USE EXCESSIVE AMOUNTS OF LIQUID WHEN WIPING ON OR AROUND THE OVEN CONTROL BOX.****IMPORTANT: EMPTY THE ASH CHUTE DAILY TO AVOID BLOCKING OR DAMAGING THE COAL BLOWER FAN. DAMAGE CAUSED BY IMPROPER MAINTENANCE IS NOT COVERED BY THE OVEN WARRANTY.****NOTE: COAL GRATES NEED TO BE REPLACED APPROXIMATELY EVERY 4–6 MONTHS.**

Coal grates are a consumable item—life will vary depending on oven temperature, hours of operation, fuel consumption, and proper use of the coal fan. It is expected that they will require replacement approximately every 4–6 months. Running the coal fan on its lowest setting overnight will help extend the life of the grates. Replacement grates are available from the factory.

**ESTABLISHING A THERMAL CLEANING SCHEDULE****GAS / COAL-FIRED OVEN**

If a Wood Stone gas-fired oven is operated at low temperatures (below 450 °F), it is possible that grease from food could condense on the walls and ceiling of the oven. To remove the grease that has accumulated on the walls and ceiling of the oven, simply raise the temperature of the oven to a temperature of 600–700 °F. Maintain this temperature for 1-2 hours, or until the dome appears clean. Then allow the oven to return to normal operating temperature. Monitor the floor temperature displayed on the Controller.

Ovens that are run at lower temperatures may also develop a buildup on the floor that is usually black in color. To remove this buildup, bring the oven temperature up to 600–700 °F as described above, and maintain that temperature for at least a few hours. If there is still buildup remaining, it may need to be removed by scraping. Contact Wood Stone for instructions.

**DO NOT POUR OR SPRAY LIQUIDS ONTO THE OVEN DECK OR INTO THE OVEN INTERIOR AS THIS CAN DAMAGE THE CERAMIC AND WILL VOID THE WARRANTY.**



SYMPTOM	PROBABLE CAUSE/SOLUTION
Controller will not turn on.	<ol style="list-style-type: none"> <li>1. Incoming power to oven turned off. Check circuit breaker for circuit supplying the oven. Check that any wall switches external to the oven that control oven power are turned on. Check that any interlocks external to the oven are turned on.</li> <li>2. If Controller still does not turn on, please contact Wood Stone for assistance.</li> </ol>
Radiant Flame Burner(s) do not light.	<ol style="list-style-type: none"> <li>1. Gas not reaching the oven. Check that gas valve is turned all the way on.</li> <li>2. Debris in burner. Burner may require cleaning. Contact Wood Stone for assistance.</li> <li>3. Damaged igniter or gas valve. Contact Wood Stone for assistance.</li> </ol> <p>If the oven is being started for the first time:</p> <ul style="list-style-type: none"> <li>- Has all air been bled from the gas line?</li> <li>- Is the switch on the SV-2, and, depending on configuration, SV-3 valve in the ON position?</li> </ul> <p><b>NOTE:</b> Valve(s) are located beneath the oven at the rear, towards the side where the Radiant Burner is located.</p>
Radiant Flame Burner cuts out	<ol style="list-style-type: none"> <li>1. Debris in burner.</li> <li>2. Oven is being run with the Night Heat Retention Door in place. Door must be removed whenever the oven is turned on.</li> <li>3. Wind blowing into the oven, or other venting issue.</li> </ol>
Underfloor Infrared (IR) Burner is not running. Hearth Heat light is off.	Hearth temperature is above the Hearth Set Point.
"Chec" display on Controller.	Underfloor Infrared (IR) Burner did not fire when the floor temperature dropped below the Hearth Set Point. Contact Wood Stone for assistance.
Plenum fan on coal-fired models does not work	<ol style="list-style-type: none"> <li>1. Make sure the fan is turned ON.</li> <li>2. Make sure the Ash Chute is empty.</li> </ol>

**Please contact Wood Stone at 1-800-988-8103 should service be necessary, or if you have any questions about your oven.** Our normal service hours are Mon.–Fri., 8am–5pm Pacific time. If calling after hours, follow the recorded instructions for emergency service and a Wood Stone technician will get back to you promptly.



### IR BURNER ONLY

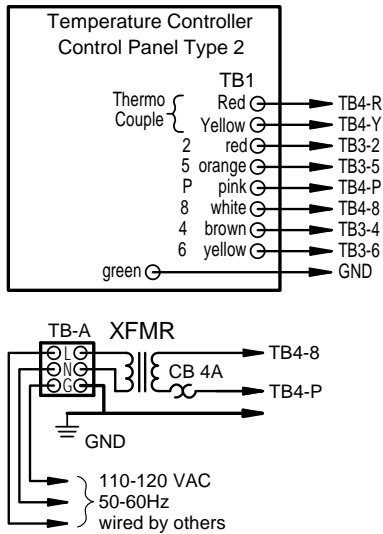

### IR Only (W-IR)

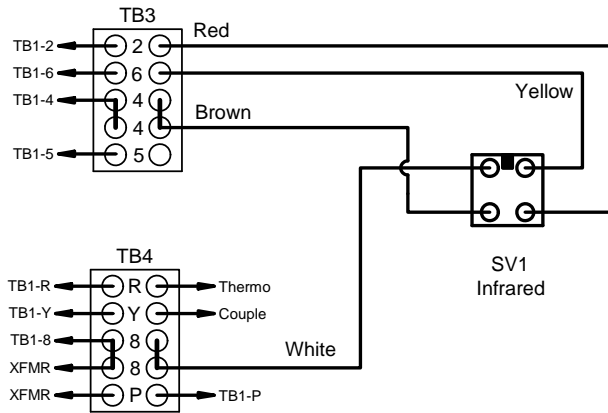

Bellingham, WA +1(360)650-1111 www.woodstone-corp.com

DIAG #: WD061 Rev. 0  
DATE: 3/28/2014

### DUAL RADIANT BURNERS AND IR BURNER

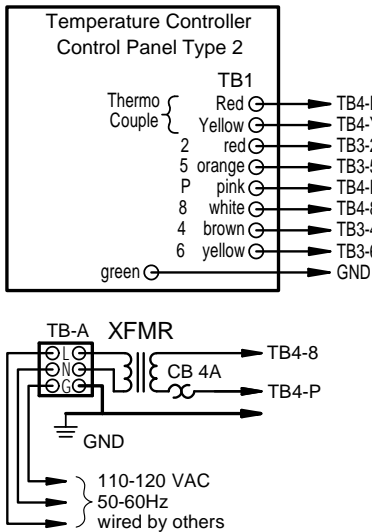

### IR w/ Dual RFG

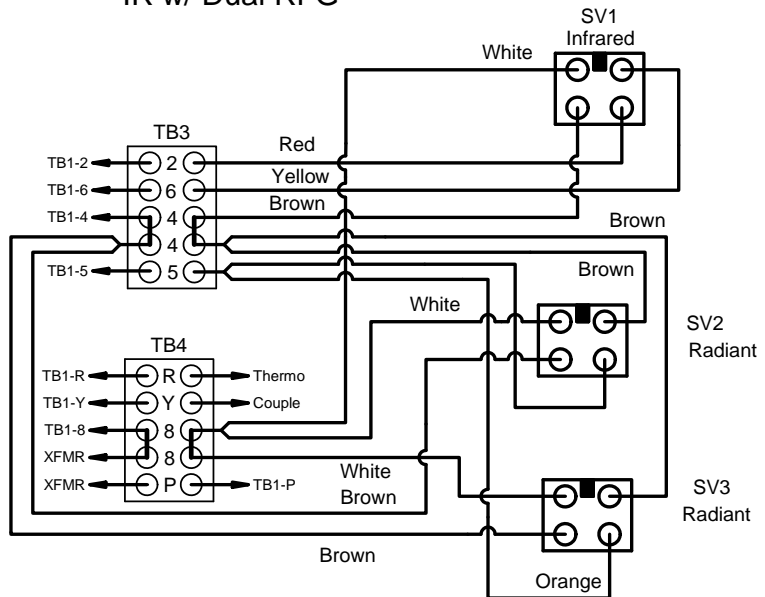

Bellingham, WA +1(360)650-1111 www.woodstone-corp.com

DIAG #: WD079 Rev. 0  
DATE: 3/27/2014



### SINGLE RADIANT BURNER AND IR BURNER

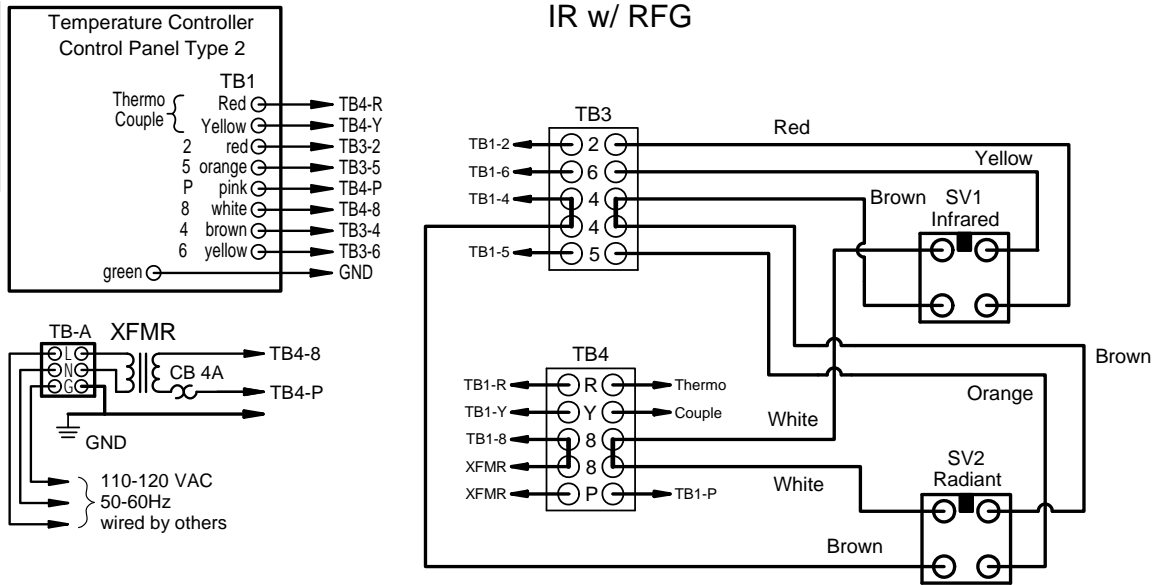

Bellingham, WA +1(360)650-1111 www.woodstone-corp.com

DIAG #: WD064 Rev. 0  
DATE: 3/28/2014

### ADD'L DUAL RADIANT BURNERS

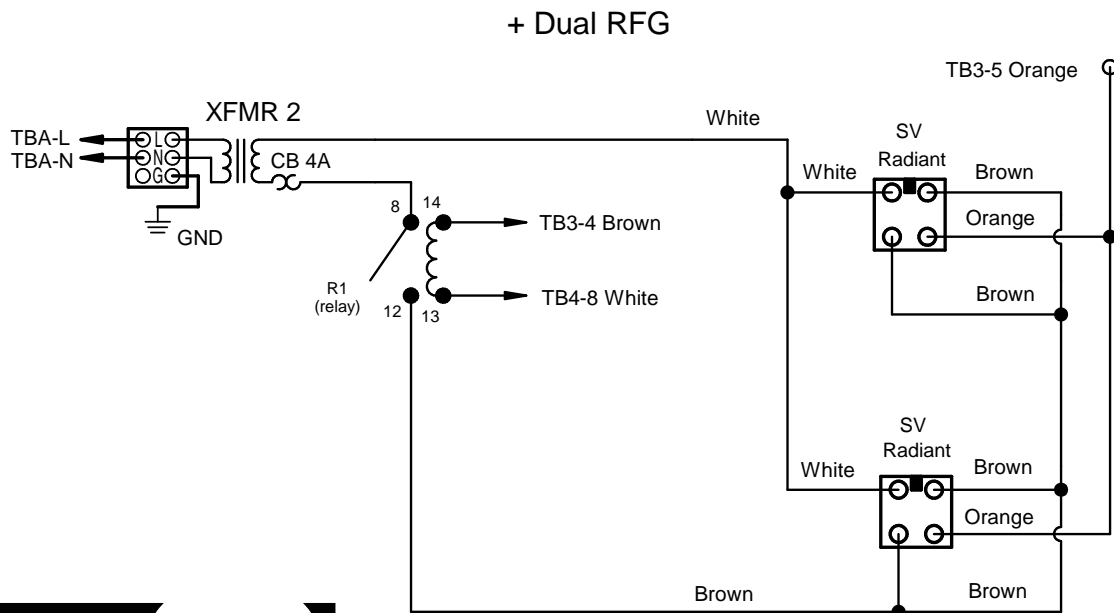

Bellingham, WA +1(360)650-1111 www.woodstone-corp.com

DIAG #: WD125 Rev. 0  
DATE: 10/21/2014





### ELECTRICAL DIAGRAM FOR COAL-FIRED OVEN BLOWER FAN

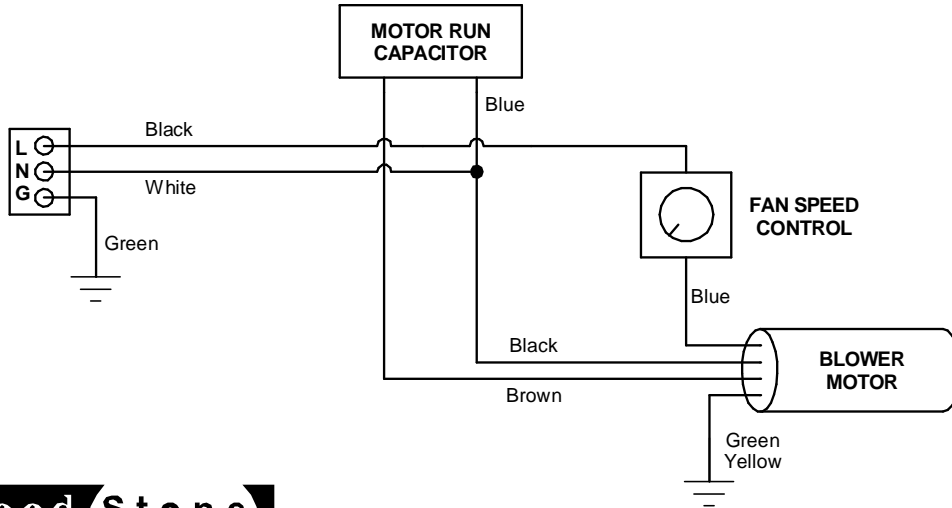

Bellingham, WA +1(360)650-1111 [www.woodstone-corp.com](http://www.woodstone-corp.com)

**DIAG #:** WD155 Rev. 0  
**DATE:** 11/9/2015

Blank page



### ALL WARRANTY SERVICE MUST BE PRE-APPROVED BY WOOD STONE

Wood Stone warrants its equipment to the original purchaser against defects in material or manufacture for a period of one year from the original date of purchase, subject to the following exclusions and limitations.

Please contact the factory first at 1.800.988.8103 or 1.360.650.1111, seven days a week. Our normal business hours are 8am to 5pm Pacific time Monday–Friday. If calling during non-business hours, follow the recorded instructions for emergency service and a Wood Stone technician will get back to you promptly.

#### EXCLUSIONS

The warranties provided by Wood Stone do not apply in the following instances:

1. In the event that the equipment is improperly installed. Proper installation is the responsibility of the installer; proper installation procedures are prescribed by the Wood Stone Installation and Operation Manual.
2. In the event the equipment is improperly or inadequately maintained. Proper maintenance is the responsibility of the user; proper maintenance procedures are prescribed in the Wood Stone Installation and Operation Manual. Burner problems resulting from debris or ash in the burner well will not be covered by the warranty. Call with questions regarding maintenance frequency.
3. In the event that the failure or malfunction of the appliance or any part thereof is caused by abnormal or improper use or is otherwise not attributable to defect in material or manufacture.
4. In the event that the appliance, by whatever cause, has been materially altered from the condition in which it left the factory.
5. In the event that the rating plate has been removed, altered or obliterated.
6. On parts that would be normally worn or replaced under normal conditions.
7. Normal cracking due to expansion and contraction stress relief in the ceramic firebox.
8. In wood-fired equipment configurations, in the event that pressed log products of any type have been burned in the equipment.
9. In coal-fired oven configurations, in the event any type of coal other than anthracite coal fuel has been used.
10. Damage resulting from the use of chemical cleaning products in the oven, as well as any damage from liquids or chemicals, including water, being poured or sprayed into the oven.

If any oral statements have been made regarding this appliance, such statements do not constitute warranties and are not part of the contract of sale. This Limited Warranty constitutes the complete, final and exclusive statement with regard to warranties.

**THIS LIMITED WARRANTY IS EXCLUSIVE AND IN LIEU OF ALL OTHER WARRANTIES WHETHER WRITTEN, ORAL OR IMPLIED, INCLUDING, BUT NOT LIMITED TO, ANY WARRANTY OF MERCHANTABILITY OR FITNESS FOR PARTICULAR PURPOSE OR WARRANTY AGAINST LATENT DEFECTS.**

#### LIMITATIONS OF LIABILITY

In the event of warranty claim or otherwise, the sole obligation of Wood Stone shall be the repair and/or replacement, at the option of Wood Stone, of the appliance or component or part thereof. Such repair or replacement shall be at the expense of Wood Stone with the exception of travel over 100 miles or two hours, overtime, and holiday charges which shall be at the expense of the purchaser. Any repair or replacement under this warranty does not constitute an extension of the original warranty for any period of the appliance or for any component or part thereof. Parts to be replaced under this warranty will be repaired or replaced at the option of Wood Stone with new or functionally operative parts. The liability of Wood Stone on any claim of any kind, including claims based on warranty, expressed or implied, contract, negligence, strict liability or any other theories shall be solely and exclusively the repair or replacement of the product as stated herein, and such liability shall not include, and purchaser specifically renounces any rights to recover, special, incidental, consequential or other damages of any kind whatsoever, including, but not limited to, injuries to persons or damage to property, loss of profits or anticipated profits, or loss of use of the product.

#### TO SECURE WARRANTY SERVICE

If you claim a defect covered by this Limited Warranty, contact:

Wood Stone Corporation, Attn: Service Department, 1801 W. Bakerview Rd., Bellingham, WA 98226 USA  
Phone 1.800.988.8103 or 1.360.650.1111



**WOOD STONE CORPORATION**

1801 W. Bakerview Rd.  
Bellingham, WA 98226 USA

Toll Free 800.988.8103

Tel 360.650.1111

Fax 360.650.1166

[www.woodstone-corp.com](http://www.woodstone-corp.com)

An ongoing program of product improvement may require us to change specifications without notice.