



WS-PL-MTL-40-35-4-CT model shown.

FEATURES

- Four Independently-Controlled Zones
- Temperature Range of 200 °F to 700 °F
- Stainless Steel Backsplash
- Removable Drip Tray

| | |
|----------|----------------------|
| Job Name | |
| Model | WS-PL-MTL-40-35-4-CT |
| Item# | |

The Wood Stone Electric Plancha features a small footprint that measures 40 inches x 35 inches with a smooth steel cooking surface 35 inches x 24 inches. Supported by four legs, it is intended for installation on a suitable countertop.

The surface of the Electric Plancha can be used as a direct contact cooking surface like a griddle for searing or sautéing, or heated up to 700 °F so that it functions more like an open burner.

This is an efficient piece of equipment that radiates less heat than a gas-fired open burner range, resulting in a cooler kitchen. With four thermostatically controlled zones, the Electric Plancha utilizes a proprietary control system developed by Wood Stone, which provides even temperature control across the entire cook surface. Its unique design ensures fast temperature recovery even in the most demanding of production environments.

The Electric Plancha arrives completely assembled, ETL Listed, ready to install and is made in the USA.

Additional product information can be found online at: woodstone-corp.com.



t. 360.650.1111
tf. 800.988.8103
f. 360.650.1166

Wood Stone Corporation
1801 W. Bakerview Rd.
Bellingham, WA 98226 USA
info@woodstone-corp.com
woodstone-corp.com

REVISED: SUMMER 2022

An ongoing program of product improvement may require us to change specifications without notice.



ELECTRIC PLANCHA

HIGH-TEMPERATURE COOK SURFACE • WS-PL-MTL-40-35-4-CT

208 VAC, 3 Phase 18.2 kW
Requires 1 ea. 50 A individual branch circuit. Single NEMA 15-50P plug.

PLAN VIEW

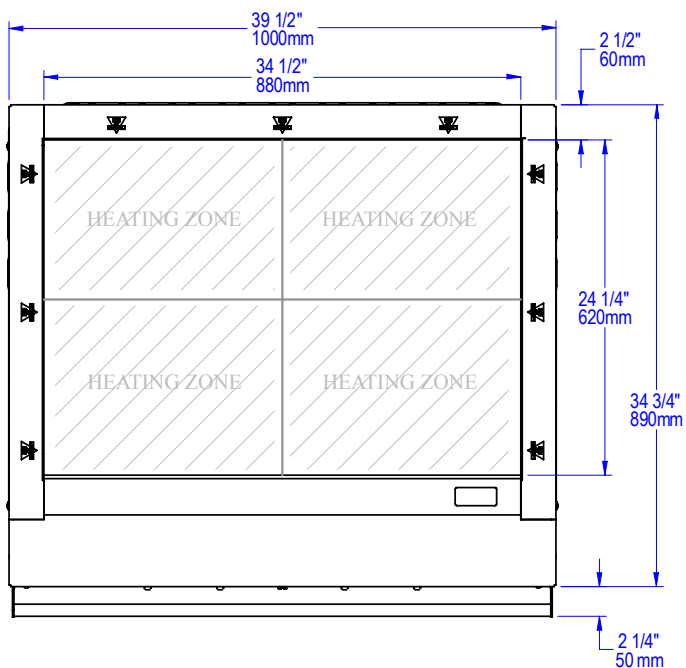

CLEARANCE INFO:

Provide a minimum of 12 inches of clearance to combustable construction from sides and back.

Allow a minimum of 3 inches of clearance around the unit to allow cooling air to enter the vents on the sides and back of the unit. Do not block the air vents on the sides, back or beneath the appliance.

FRONT VIEW

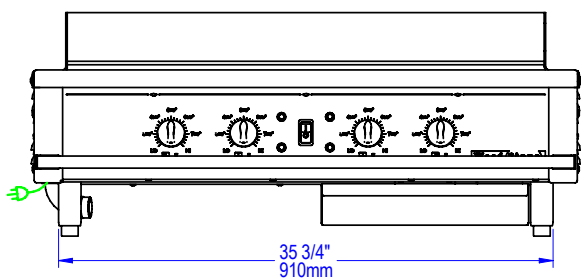

SIDE VIEW

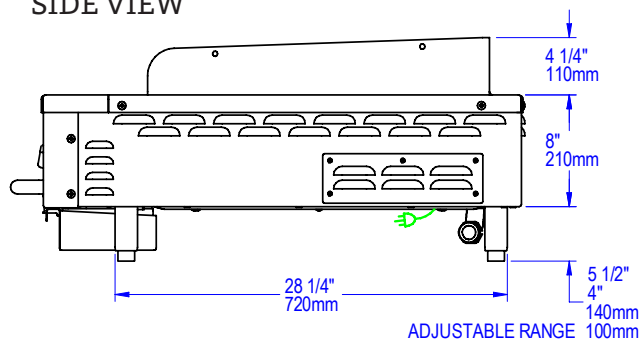

UTILITIES SPECIFICATIONS

GAS
N/A

ELECTRICAL
Units are cord-connected. 208 VAC 3 Phase, 18.2 kW. 50A individual branch circuit. NEMA 15-50P Plug provided

VENTING INFORMATION

The Wood Stone Electric Plancha must be vented in accordance with NFPA 96 and all relevant local and national codes, and in a manner acceptable to the authority having jurisdiction.

Ship Weight: 525 lbs / 238 kg



t. 360.650.1111
tf. 800.988.8103
f. 360.650.1166

Wood Stone Corporation
1801 W. Bakerview Rd.
Bellingham, WA 98226 USA
info@woodstone-corp.com
woodstone-corp.com

REVISED: SUMMER 2022

An ongoing program of product improvement may require us to change specifications without notice.

