



WS-MS-7 model with optional Stainless Steel Mantle shown.

HEARTH CAPACITY

8" pizzas:	36–40
10" pizzas:	22–26
12" pizzas:	16–20
16" pizzas:	8–10

Assuming 5-minute cook times, the approximate maximum hourly production capacity can be calculated by multiplying the above numbers by 12. Cook times will also vary depending on "style" of pizza.

GUIDE TO MODEL NUMBERS

	Radiant Flame	Underfloor IR Burner	Wood Required	Combination	Natural Gas BTU/hr	Liquid Propane BTU/hr
WS-MS-7-RFG	X				-NG 123,000	-LP 142,000
WS-MS-7-RFG-W	X			X	-NG 123,000	-LP 142,000
WS-MS-7-RFG-IR	X	X			-NG 220,000	-LP 227,000
WS-MS-7-RFG-IR-W	X	X		X	-NG 220,000	-LP 227,000
WS-MS-7-W-IR		X	X		-NG 97,000	-LP 85,000
WS-MS-7-W			X			

MT. RAINIER 7' STONE HEARTH OVEN



Job Name	
Model	WS-MS-7
Item#	

The Mt. Rainier 7' oven features a door opening 42 inches wide x 12 inches high. The oven floor diameter is 74 inches, resulting in a 31-square-foot cooking surface. A tensioned steel exoskeleton surrounding the hearth and dome perimeter ensures structural integrity and longevity. Wrapped in spun ceramic fiber insulation and requiring only a 1-inch side clearance to combustibles, the monolithic 4-inch thick cast-ceramic hearth and monolithic 4-inch thick dome rest on an open black painted steel stand. The oven body is finished with galvanized steel and a stainless steel service panel is provided. The oven arrives completely assembled, ETL Listed, ready to install and is made in the USA. Information about custom finishes, tools and accessories can be found online at: woodstone-corp.com.

FUEL CONFIGURATIONS

GAS-FIRED ONLY: Configured to burn either natural gas (NG) or liquid propane (LP).*

RADIANT FLAME (RFG): Heated by an easily adjustable radiant flame (123,000 BTU/hr max. NG) located in the rear of the cooking chamber. User control ensures the ability to balance the oven's radiated top heat with the heat being conducted and radiated from the floor.

RADIANT FLAME + UNDERFLOOR IR (RFG-IR): In addition to the radiant flame, a 97,000 BTU/hr (NG) thermostatically controlled infrared burner is mounted under the oven deck to ensure high production capacity with no heat recovery issues.

WOOD-FIRED (W): Wood-fired only.

WOOD WITH GAS ASSIST (W-IR): This wood-fired model is assisted by the additional BTUs of an Underfloor IR burner. **Note:** A wood fire is required with this configuration.

COMBINATION (-W): Allows optional wood burning for ovens with gas burner configurations.* **Note:** Adding wood to an oven with an RFG burner will reduce available hearth capacity.

*Gas type must be specified at time of order.



t. 360.650.1111
tf. 800.988.8103
f. 360.650.1166

Wood Stone Corporation
1801 W. Bakerview Rd.
Bellingham, WA 98226 USA
info@woodstone-corp.com
woodstone-corp.com

REVISED: SUMMER 2021

An ongoing program of product improvement may require us to change specifications without notice.



MT. RAINIER 7'

STONE HEARTH OVEN • WS-MS-7

PLAN VIEW

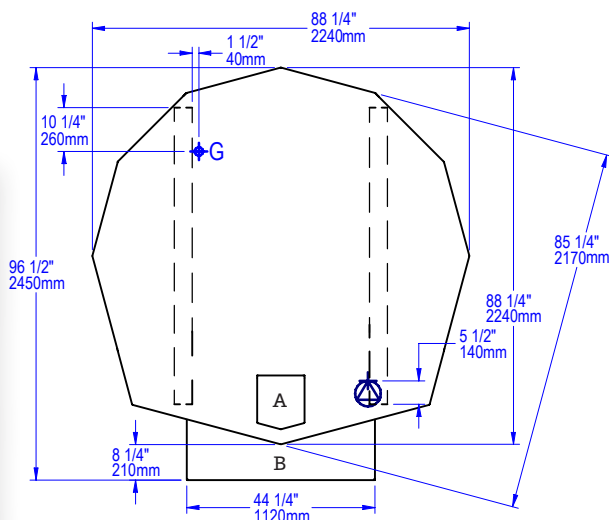

FRONT VIEW

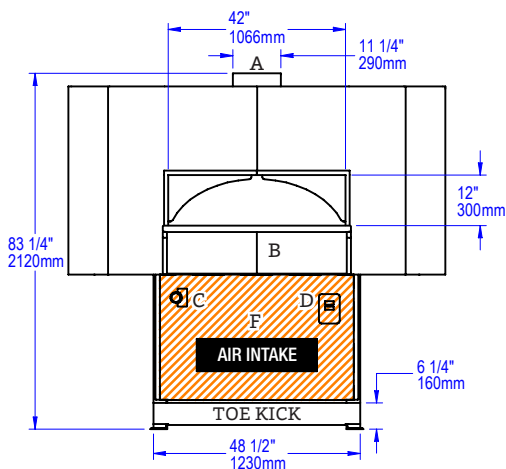

FACADE INFORMATION

- All facades or enclosures are by others.
- All MS ovens require a 1" side clearance and 6" top clearance to combustible construction. Any construction 6" to either side of the oven doorway and above must be non-combustible.
- Any facade or enclosure below the mantle of Gas-Fired or Combination ovens must allow for:
 - Unobstructed access for removal of service/intake panel.
 - Easy access to all controls.
 - Sufficient combustion air for gas burners; see Installation and Operation Manual for details.

SIDE VIEW

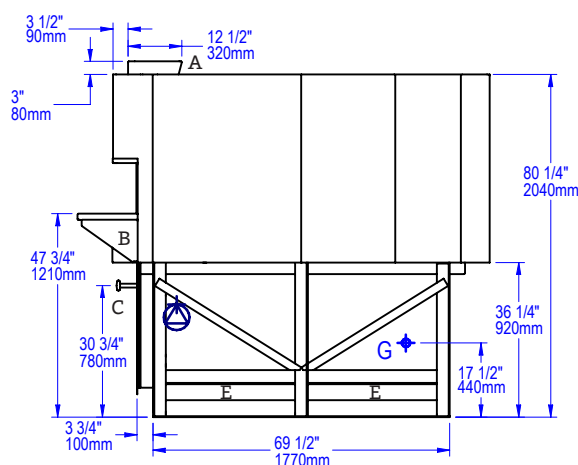

A	Flue Collar
B	Mantle
C	Flame Height Control Knob
D	Digital Controller
E	Forklift Here
	Electrical Connection
F	Service Panel or Optional Storage Box
	Gas Connection
	Must Be Left Removable for Service
	AIR INTAKE: Do Not Facade or Cover Over

UTILITIES SPECIFICATIONS

GAS
3/4 inch gas inlet (FNPT)

BTU/hr Requirements
See table on previous page

ELECTRICAL
Gas-Fired Only & Combination
120 VAC, 1.1 A, 50/60 Hz
Connection made beneath oven as shown.

Wood-Fired Only
120 VAC, 2 A, 50/60 Hz
Connection made to readout box.

VENTING INFORMATION

The Mt. Rainier can be direct connected to a power-ventilated, grease-rated chimney or can be vented with a Listed Type 1 exhaust hood, or one constructed in accordance with NFPA 96 and all relevant local and national codes. The oven must be vented in accordance with all relevant local and national codes, and in a manner acceptable to the authority having jurisdiction.

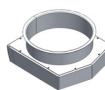

Note: A 10" ID flue adapter is included with ovens ordered without a hood to facilitate connection to a round duct (adds 3" to height).

Ship Weight: 6,000 lbs / 2,722 kg



t. 360.650.1111
tf. 800.988.8103
f. 360.650.1166

Wood Stone Corporation
1801 W. Bakerview Rd.
Bellingham, WA 98226 USA
info@woodstone-corp.com
woodstone-corp.com

REVISED: SUMMER 2021

An ongoing program of product improvement may require us to change specifications without notice.

