



**WARNING: THE OVEN IS EXTREMELY TOP HEAVY.**

**DO NOT ATTEMPT TO MOVE THE OVEN WITHOUT THE PROPER EQUIPMENT AND EXPERIENCE. BE SAFE.**

**ALWAYS USE A FORKLIFT OR CRANE TO LIFT THIS OVEN.**

**DO NOT ATTEMPT TO USE A LEVER OF ANY TYPE TO RAISE THIS OVEN.**

**THE OVEN IS EQUIPPED WITH CASTERS AND CAN BE ROLLED ACROSS A SMOOTH, FLAT SURFACE ONLY.**

**Once the oven is in place, the casters must be removed. See the **CASTER REMOVAL** section of the manual.**

**DO NOT DROP THIS OVEN ABRUPTLY.**

Moving a Wood Stone Fire Deck oven can present challenges to even the most experienced riggers. Make sure to secure the proper equipment and make safety your first priority. Please don't hesitate to call the factory for technical support at **1-800-988-8103**.

### USING A FORKLIFT

Use a forklift with adequate fork lengths and lifting capacity. When using a forklift, always use the forklift pockets; lifting the oven any other way may result in damage. There are fork pockets only at the front and back of the oven. The oven may also be rolled across a **smooth flat** surface on the temporary casters.

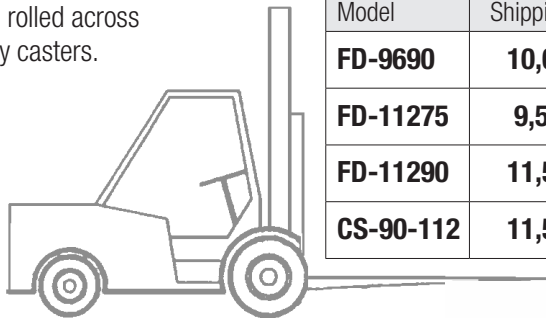

<b>⚠ WARNING</b>		
<b>Minimum Required Forklift Capacities</b>		
<b>8' FORKS MINIMUM</b>		
Model	Shipping Weight	Lifting from Front or Rear
<b>FD-9690</b>	<b>10,000 lbs</b>	<b>24,000 lbs</b>
<b>FD-11275</b>	<b>9,500 lbs</b>	<b>20,000 lbs</b>
<b>FD-11290</b>	<b>11,500 lbs</b>	<b>26,000 lbs</b>
<b>CS-90-112</b>	<b>11,500 lbs</b>	<b>26,000 lbs</b>

### USING A CRANE

When craning a Wood Stone oven, use a Spreader Bar with a two-legged sling rigged on each end. Suitable lifting straps can be run through the fork lift pockets on the oven. The Spreader Bar should be of a sufficient length to keep the sling from contacting the oven and oriented as shown in (fig. 1).

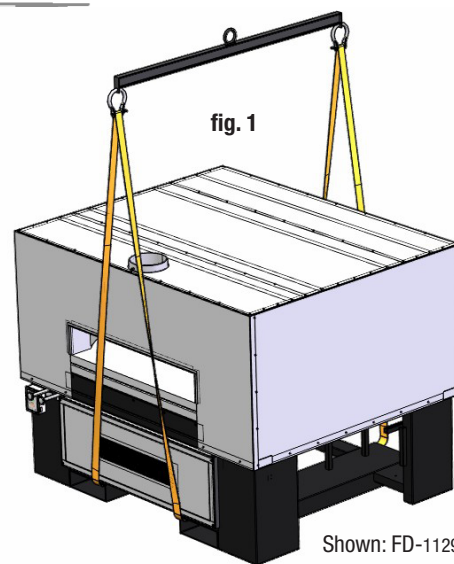

**IF YOU ARE PLANNING TO USE A CRANE TO UNLOAD THE OVEN, SPECIFY A FLATBED TRUCK DELIVERY!**

**NOTE:** Remove Oven Mantle before lifting the oven with a crane.

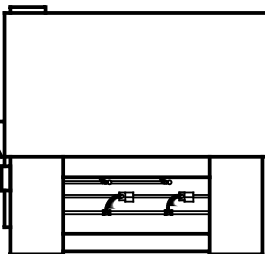

### DELIVERY NOTE

The customer will receive an Oven Shipping Notification when the oven leaves the Wood Stone factory. This will include a PRO# and a trucking company contact number. Wood Stone recommends that you confirm the delivery date/time with the trucking company before committing to heavy equipment and/or labor. Our goal is a smooth and safe delivery.



The oven is shipped with casters which add 1-1/2". Height with casters to the top of the flue collar is 87-3/4".

**TO MAINTAIN THE OVEN WARRANTY, SHIPPING CASTERS MUST BE REMOVED WHEN THE OVEN IS INSTALLED.**

The oven must be installed on a flat level surface. The weight of the oven is carried by the oven stand. If it is necessary to shim the oven for leveling purposes, it is critical that the shim material be metal, and that the shims are installed in such a way that the stand is solidly supported. **Failure to solidly support the oven stand can result in costly damage to the oven and will void the warranty.**

The floor design and construction must be adequate to handle the weight of the oven.

Please see [woodstone-corp.com](http://woodstone-corp.com) for floor loading information.

**IMPORTANT: DO NOT JACK THE FRAME ANY HIGHER THAN THE MINIMUM NECESSARY TO REMOVE THE CASTER.**

- Position a scissor jack under the oven frame near the caster to be removed.  
 Use the jack to raise the caster so that it clears the floor slightly (1/4" should be sufficient).

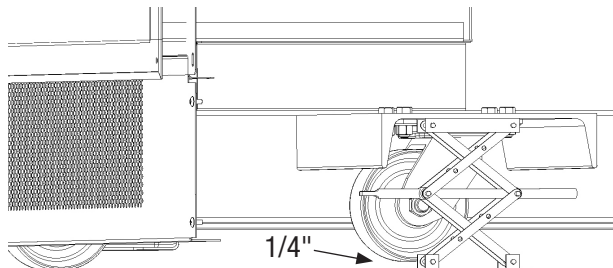

- Remove the nuts and bolts retaining the caster to the oven frame.

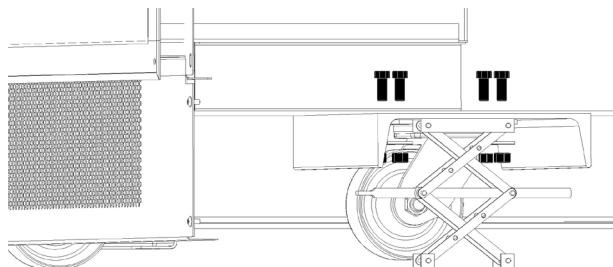

- Rotate the caster in the direction of the fork legs to remove from oven.  
 Lower the jack and proceed to the next caster and repeat procedure.

