

Job Name	
Model	WS-BL-4355
Item#	

The Bistro 4355 oven features a door opening 24.5 inches wide x 7.5 inches high. The cooking area is 34 inches wide x 39 inches deep, resulting in a 9.2-square-foot cooking surface. A tensioned steel exoskeleton surrounding the hearth and dome perimeter ensures structural integrity and longevity. Wrapped in spun ceramic fiber insulation and requiring only a 1-inch side clearance to combustibles, the monolithic cast-ceramic hearth and monolithic dome rest on a black powder coat steel stand while the oven body is enclosed with stainless steel.

The oven arrives completely assembled. However, using the optional Lifting System, the oven can be partially disassembled to fit through a 32-inch doorway—see the Installation and Operation Manual for details. It is ETL Listed, ready to install and is made in the USA.

Information about custom finishes, tools and accessories can be found online at: woodstone-corp.com.

HEARTH CAPACITY

8" pizzas:	9–12
10" pizzas:	9
12" pizzas:	6
16" pizzas:	4

Assuming 5-minute cook times, the approximate maximum hourly production capacity can be calculated by multiplying the above numbers by 12. Cook times will also vary depending on "style" of pizza.

FEATURES

- Compact Footprint
- Visible Flame
- Medium Production
- High-Temp Cooking
- 3–5 Minute Pizzas

GUIDE TO MODEL NUMBERS

	Radiant Flame	Wood-Fired Only	Combination	Natural Gas	Liquid Propane
WS-BL-4355-RFG	X			-NG	-LP
WS-BL-4355-RFG-W	X		X	-NG	-LP
WS-BL-4355-W		X			

FUEL CONFIGURATIONS

GAS-FIRED ONLY: Configured to burn either natural gas (NG) or liquid propane (LP).*

RADIANT FLAME (RFG): Heated by an easily adjustable radiant flame (80,500 BTU/hr max. NG) located in the rear of the cooking chamber. User control ensures the ability to balance the oven's radiated top heat with the heat being conducted and radiated from the floor.

WOOD-FIRED (W): Wood-fired only.

COMBINATION (-W): Allows optional wood burning for ovens with gas burner configurations.* **Note:** Adding wood to an oven with an RFG burner will reduce available hearth capacity.

*Gas type must be specified at time of order.



t. 360.650.1111
tf. 800.988.8103
f. 360.650.1166

Wood Stone Corporation
1801 W. Bakerview Rd.
Bellingham, WA 98226 USA
info@woodstone-corp.com
woodstone-corp.com

REVISED: SUMMER 2021

An ongoing program of product improvement may require us to change specifications without notice.



BISTRO 4355

STONE HEARTH OVEN • WS-BL-4355

A	Flue Collar
B	Mantle
C	Flame Height Control Knob
D	Digital Controller
E	Forklift Here
	Electrical Connection
F	Service Panel or Optional Storage Box
	Gas Connection
	Must Be Left Removable for Service
AIR INTAKE: Do Not Facade or Cover Over	

PLAN VIEW

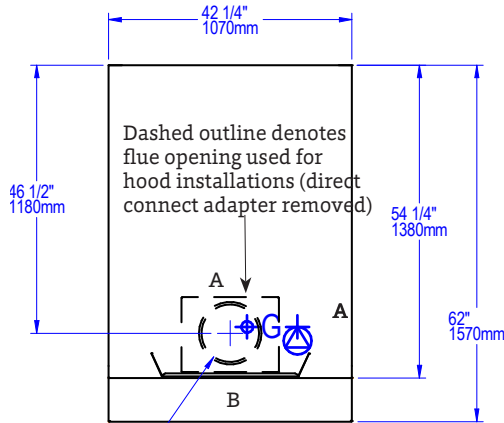

REAR VIEW

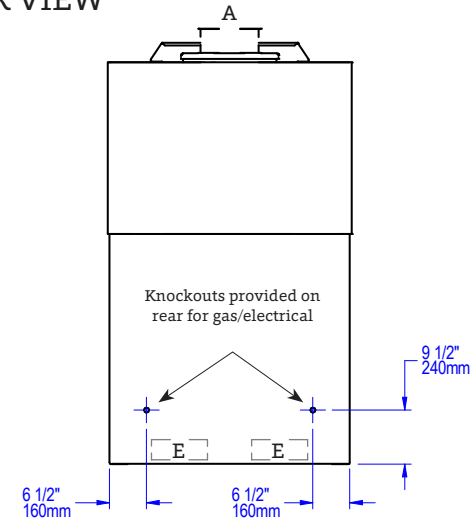

FRONT VIEW

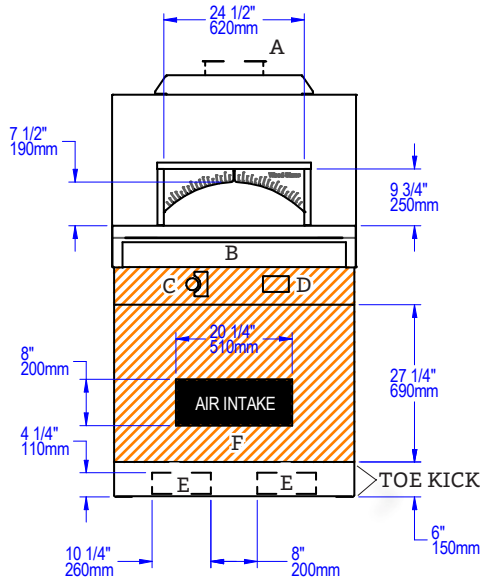

SIDE VIEW

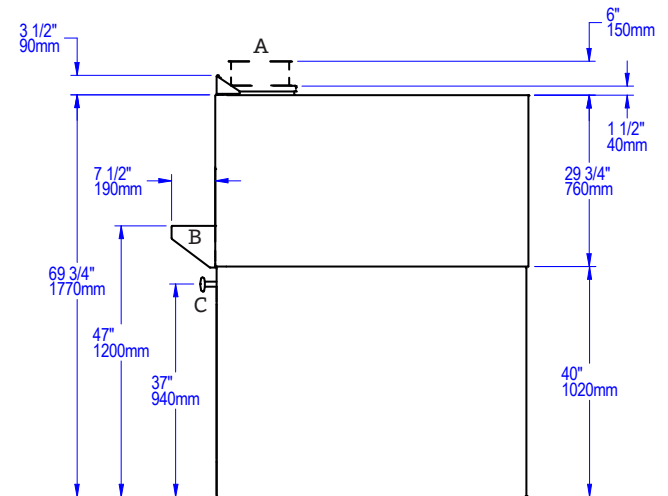

UTILITIES SPECIFICATIONS

GAS
Gas-Fired Only and Combination
 3/4 inch gas inlet (FNPT)
 80,500 BTU/hr - Natural Gas (NG)
 OR
 68,000 BTU/hr - Propane (LP)

ELECTRICAL
All Models
 120 VAC, 2 A, 60 Hz
 Connection made on the back of the oven control box. Remove front panel for access; use utility knockouts (provided) to route gas and electrical supplies.

VENTING INFORMATION

The Bistro 4355 has a 10-inch O.D. flue collar and can be direct connected to a power-ventilated, grease-rated chimney or can be vented with a Listed Type 1 exhaust hood, or one constructed in accordance with NFPA 96 and all relevant local and national codes. The oven must be vented in accordance with all relevant local and national codes, and in a manner acceptable to the authority having jurisdiction.

Ship Weight: 2,500 lbs / 1,134 kg



t. 360.650.1111
 tf. 800.988.8103
 f. 360.650.1166

Wood Stone Corporation
 1801 W. Bakerview Rd.
 Bellingham, WA 98226 USA
info@woodstone-corp.com
woodstone-corp.com

REVISED: SUMMER 2021

An ongoing program of product improvement may require us to change specifications without notice.

