

Installation and Operation Manual



MT. OLYMPUS

Rotisserie

*Solid Fuel, Narrow / Standard Width,
Optional Extended Firebox Broiler,
Six- and Ten-Spit Models*

MT. OLYMPUS WS-SFR

Wood Stone

WOOD STONE CORPORATION

1801 W. Bakerview Rd.
Bellingham, WA 98226 USA

Toll Free 800.988.8103

Tel 360.650.1111

Fax 360.650.1166



TABLE OF CONTENTS

MT. OLYMPUS 3
CAUTIONS & WARNINGS 4
SPECIFICATIONS 6
RECEIVING THE ROTISSERIE 7
HEAT SHIELD INSTALLATION. 8
CLEARANCES 9
VENTING 10
CONTROLLER 11
FUELING THE CHARBROILER. 12
FUEL SAFETY. 14
DAILY OPERATION 15
CLEANING THE ROTISSERIE 16
OPTIONAL SPITS 17
PREVENTIVE MAINTENANCE. 18
FUELWOOD FACTS. 19
ELECTRICAL DIAGRAM. 20
LIMITED WARRANTY 21



**INSTALLATION AND OPERATION MANUAL FOR THE
WOOD STONE MT. OLYMPUS ROTISSERIE,
WITH OPTIONAL NARROW WIDTH,
AND/OR OPTIONAL EXTENDED CHARBROILER**

STONE-FIRED COOKING EQUIPMENT

SOLID FUEL ROTISSERIE

WS-SFR-(6,10)-(N)-(SB)

ADDITIONAL MANUAL COPIES AVAILABLE UPON REQUEST



Shown: SFR-6 with optional
extended charbroiler and
wood cart

**INSTALLATION AND OPERATING INSTRUCTIONS FOR THE WOOD STONE
MODELS WS-SFR-(6,10)-(N)-(SB) MT. OLYMPUS SOLID FUEL ROTISSERIE****RETAIN THIS MANUAL FOR FUTURE REFERENCE**Additional copies of this manual at woodstone-corp.com.

For prompt responses to service/maintenance questions, call us at @ 1-800-988-8103.

READ ALL INSTRUCTIONS BEFORE INSTALLING AND USING THIS APPLIANCE

Please read this entire manual before you install the appliance. Failure to follow instructions may result in property damage, bodily injury or even death. Contact your local building or fire officials about restrictions and installation inspection in your area.

WHEN THIS OVEN IS NOT PROPERLY INSTALLED, A FIRE MAY RESULT. TO REDUCE THE RISK OF FIRE, FOLLOW THE INSTALLATION INSTRUCTIONS. IT IS RECOMMENDED THAT THIS OVEN BE INSTALLED, MAINTAINED AND SERVICED BY AUTHORIZED PROFESSIONALS.

WARNING: Improper installation, adjustment, alteration, service or maintenance can result in property damage, injury or death. Read the installation, operation and maintenance instructions thoroughly before installing or servicing this equipment.

FOR YOUR SAFETY: Do not store or use gasoline or other flammable vapors or liquids in the vicinity of this or any other appliance. Always keep the area under and around this appliance free and clear of any and all combustible materials. Wood fuel should be stored in accordance with the Standard for Ventilation Control of Fire Protection of Commercial Cooking Operations, NFPA 96, and local authorities having jurisdiction.

CAUTION: DISCONNECT POWER TO THE OVEN BEFORE SERVICING OR CLEANING.

A MAJOR CAUSE OF OVEN RELATED FIRES IS A FAILURE TO MAINTAIN REQUIRED CLEARANCES TO COMBUSTIBLE MATERIAL. IT IS OF UTMOST IMPORTANCE THAT THIS OVEN BE INSTALLED ONLY IN ACCORDANCE WITH THESE INSTRUCTIONS.



**DO NOT USE PRODUCTS NOT SPECIFIED FOR USE WITH THIS APPLIANCE.
USE SOLID WOOD FUEL ONLY.**

CAUTIONS:

- (i) DO NOT INSTALL IN A MOBILE HOME.
- (ii) DO NOT CONNECT TO USE IN CONJUNCTION WITH ANY AIR DISTRIBUTION DUCTWORK UNLESS SPECIFICALLY APPROVED FOR SUCH INSTALLATIONS.
- (iii) DO NOT USE CHEMICALS OR FLUIDS TO START THE FIRE
- (iv) DO NOT BURN GARBAGE OR FLAMMABLE FLUIDS SUCH AS GASOLINE, NAPHTHA OR ENGINE OIL.
- (v) HOT WHILE IN OPERATION. KEEP CHILDREN, CLOTHING AND FURNITURE AWAY. CONTACT MAY CAUSE SKIN BURNS.

CAUTION: TO REDUCE THE RISK OF FIRE, THE APPLIANCE IS TO BE MOUNTED ON FLOORS OF NON-COMBUSTIBLE CONSTRUCTION WITH NON-COMBUSTIBLE FLOORING AND SURFACE FINISH AND WITH NO COMBUSTIBLE MATERIAL AGAINST THE UNDERSIDE THEREOF, OR ON NONCOMBUSTIBLE STABS OR ARCHES HAVING NO COMBUSTIBLE MATERIAL AGAINST THE UNDERSIDE THEREOF, SUCH CONSTRUCTION SHALL IN ALL CASES EXTEND NOT LESS THAN 12 INCHES BEYOND THE EQUIPMENT ON ALL SIDES.

PRUDENCE: POUR RÉDUIRE LE RISQUE DE FEU, L'APPAREIL EST ÊTRE MONTÉ SUR LES PLANCHERS DE CONSTRUCTION INCOMBUSTIBLE AVEC LE REVÊTEMENT DE SOL INCOMBUSTIBLES ET DE FIN DE SURFACE ET AVEC LE MATÉRIEL NON COMBUSTIBLE CONTRE LE DESSOUS DE CELA, OU SUR LES DALLES OU LES ARCS INCOMBUSTIBLES AYANT LE MATÉRIEL NON COMBUSTIBLE CONTRE LE DESSOUS DE CELA, TELLE CONSTRUCTION FAIT DANS TOUS CAS NE S'ÉTEND PAS MOINS QUE 12 POUÇES AU-DELÀ DE L'ÉQUIPEMENT DE TOUS CÔTÉS.

SAVE THE INSTRUCTIONS

Wood Stone's Mt. Olympus solid fuel rotisserie was tested and approved by Intertek Testing Services, and is ETL Listed to ANSI/UL 197, CSA C22.2 No. 109, ANSI/UL 1482, UL Subject 2162, ULC-S627-00 and NSF/ANSI Standard 4.





The only difference between the SFR-6 and SFR-10 is the number of spits. All other dimensions are the same.

Plan view

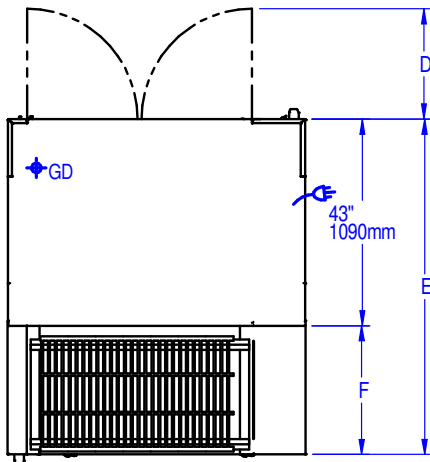

Rear view

(determines drive side; left side shown)

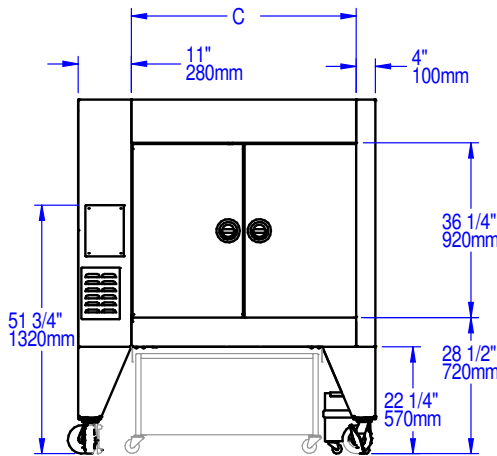

Front view

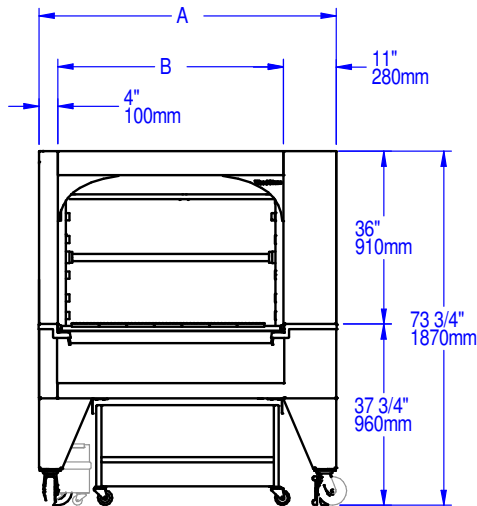

Side view

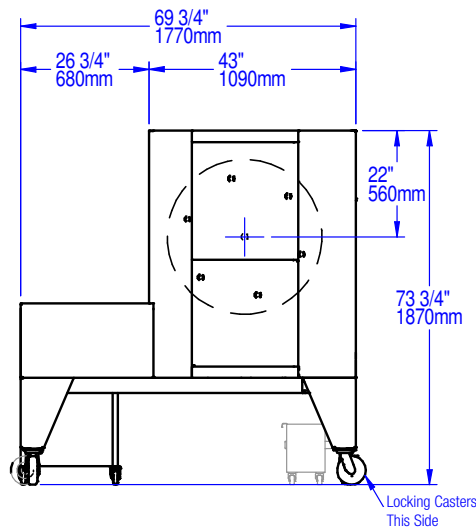

Variable Dimensions		
	SFR-6	SFR-6 w/ broiler
A	62"	62"
B	47"	47"
C	47"	47"
D	23-1/2"	23-1/2"
E	58"	70"
F	14-3/4"	26-3/4"

Variable Dimensions		
	SFR-6N	SFR-6N w/ broiler
A	50"	50"
B	35"	35"
C	35"	35"
D	17-1/2"	17-1/2"
E	58"	70"
F	14-3/4"	26-3/4"

See page 15 for spit placement dimensions.

Shipping weight: SFR-6(N): 2,000 lbs. / SFR-6(N) w/ broiler: 2,900 lbs.

UTILITIES SPECIFICATIONS

Electrical

120 VAC, 2.5 A, 60 Hz

The rotisserie comes with a detachable power cord. Provide a grounded 120 VAC, 15 or 20 A outlet. Cord connector underneath rotisserie on control side of unit. NEMA 5-15 plug.

Water

Drain: 1-1/2" outlet tube

All utility connections made on bottom of the unit.

Refer to data plate when installing.

Venting

The Mt. Olympus Rotisserie must be vented using a Listed Type 1 exhaust hood, or one constructed in accordance with NFPA 96 and all relevant local and national codes, and in a manner acceptable to the authority having jurisdiction.

IMPORTANT: This model must be vented as a solid fuel appliance.

**UNLOADING THE ROTISSERIE**

The crated Mt. Olympus with the optional extended broiler weighs 2,900 lbs. and is roughly 6' x 6'. A 5,000 lb. capacity forklift with extensions should be used for unloading the unit from the delivery vehicle. Approach the crated rotisserie from the side and insert the evenly spaced forks under the wooden skid.

MOVING THE ROTISSERIE

The crated rotisserie can be moved using a forklift, if space allows. Alternatively, a 3,000 lb. pallet jack can be used.

UN-CRATING THE ROTISSERIE

Position the forklift at the front or rear of the rotisserie. Adjust the forks so that they are just narrow enough to fit within the stainless angles on the bottom of the unit. Remove the crating. **Do not rest the rotisserie on the stainless angles.** If the rotisserie must be set down before the legs are mounted, support the unit using appropriately arranged blocks which extend beyond the sides.

LEG / CASTER POSITIONING & ASSEMBLY

The legs/casters of the rotisserie must be installed in its proper position prior to setting the unit in place. Each leg is numbered, corresponding to the number written on the underside corners of the cabinet body.

The rotisserie must be raised more than 23 inches from the floor in order to mount the legs. Each leg is firmly attached using the four 3/4 inch bolts provided. Once all four legs are securely attached, the rotisserie can be lowered into place. **Seal all legs to the cabinet using the silicone sealant provided.**



PLACEMENT OF THE STAINLESS STEEL SACRIFICIAL HEAT SHIELD

The heavy-gauge stainless steel sacrificial heat shield should be installed in the rear of the firebox. The piece is contoured to fit into place over the seam between the ceramic firebox and the stainless steel drip zone.

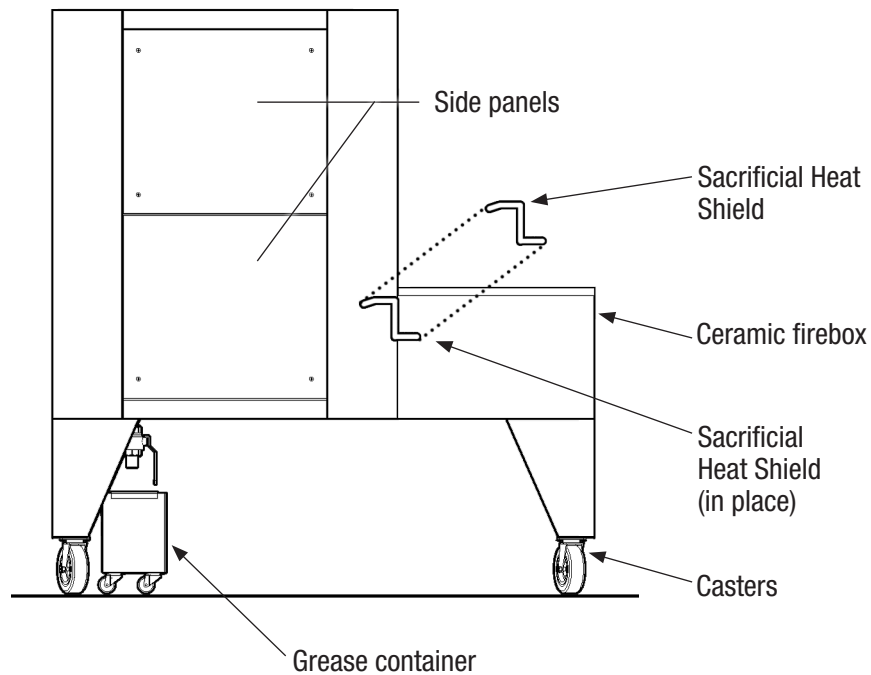



INSTALLATION CLEARANCES

WARNING: DO NOT PACK REQUIRED AIR SPACE WITH INSULATION OR OTHER MATERIALS.

FLOOR

For use on only on noncombustible floors (installer sur un plancher incombustible seulement). Install this unit on a non-combustible floor or provide a non-combustible floor covering. Measured from the front and sides of the firebox, a minimum of clearance of 36 inches under the unit, 30 inches to each side, and 36 inches in front is required.

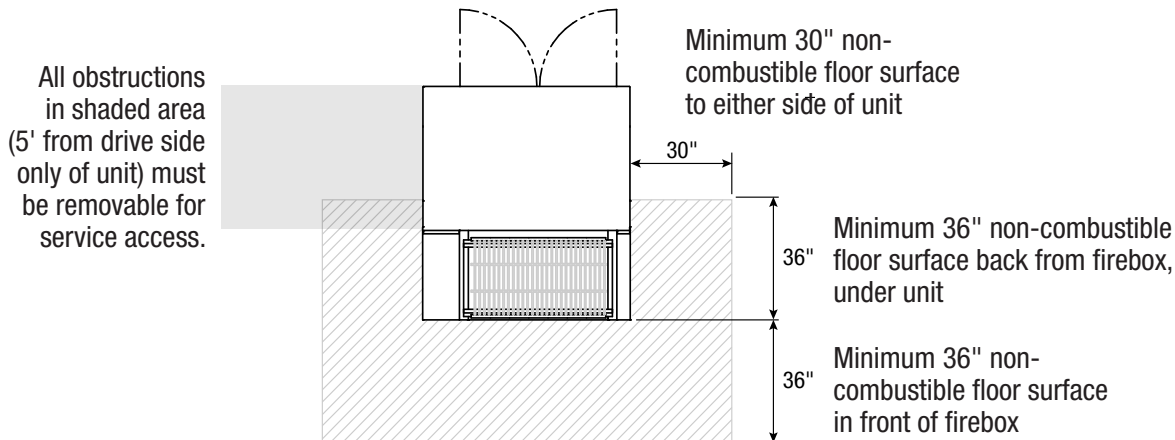

SIDES

Combustible walls must not come into contact with this unit. Without air circulation, a 3-inch clearance is required between the rotisserie and combustible construction. With air circulation, clearance to combustible construction is reduced to 1 inch.

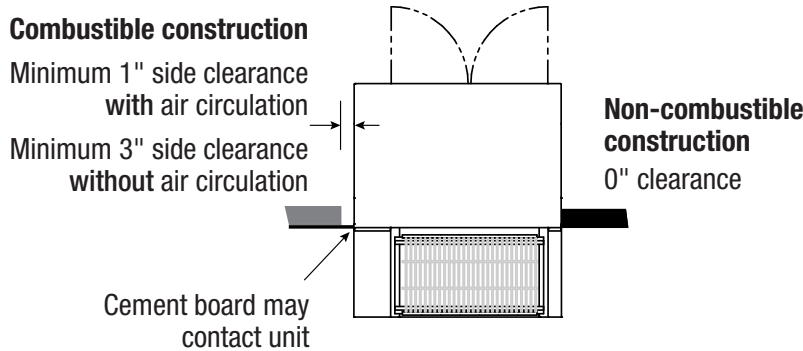

TOP

Combustible ceilings must maintain a minimum clearance of 18 inches from the top of the rotisserie.

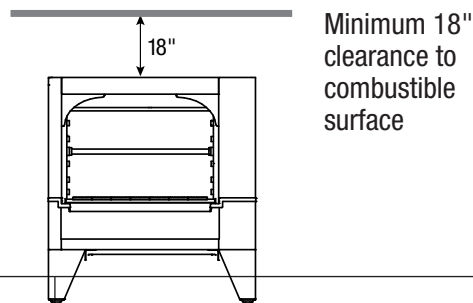



VENTING

The hood and ductwork used to vent the Mt. Olympus rotisserie must be manufactured and installed in accordance with national and local code requirements for solid-fuel broilers. This appliance must be vented with a Listed Type 1 exhaust hood or one constructed and installed in accordance with NFPA 96.

As with all solid fuel cooking equipment and exhaust systems, **a regular inspection and cleaning schedule is needed to prevent the possibility of fire.** The frequency of inspection and cleaning will depend on hours of use and type and quality of fuelwood. Typically solid fuel installations will require cleaning and inspection at least monthly.

CREOSOTE: FORMATION AND NEED FOR REMOVAL

Creosote should be removed to reduce risk of fire. When wood is burned slowly, it produces tar and other organic vapors that combine with expelled moisture to form creosote. The creosote vapors condense in a relatively cool oven flue and exhaust hood of a slow burning fire. As a result, creosote residue accumulates on the flue lining and exhaust hood. When ignited, the creosote makes an extremely hot fire. The oven flue should be inspected twice monthly to determine when creosote build up has occurred. When creosote has accumulated, it should be removed to reduce risk of fire.

**CALL WOOD STONE FOR INFORMATION AND INSTALLATION SPECIFICATIONS
ON GAYLORD HOODS, DESIGNED SPECIFICALLY FOR THE MT. OLYMPUS ROTISSERIE.**



CONTROLLER

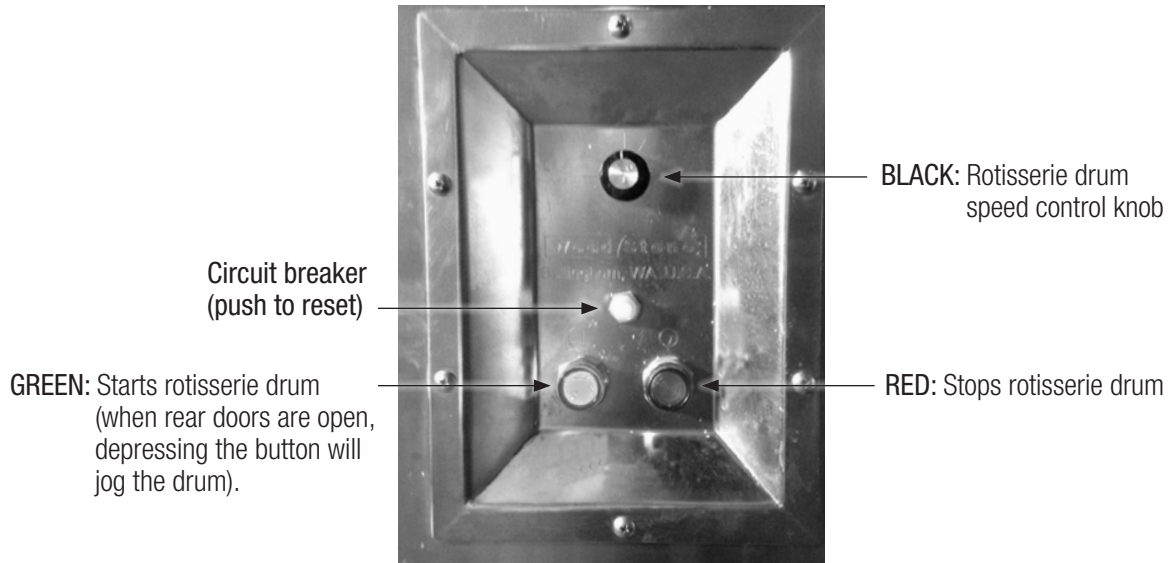

TROUBLESHOOTING

If drum fails to start after depressing **GREEN** start rotation button:

1. Check the circuit that oven is connected to at the outlet and/or circuit breaker
2. Press the Push Button Circuit Breaker, located in center of controller



It is necessary to develop a consistent and simple fuel, fire and temperature management plan for cooking on your wood-fired charbroiler. This plan should be based on the most appropriate grill temperatures for your products. We have outlined the basic steps below to begin operating your charbroiler.



TO BEGIN

1. Pull the grate rack forward, and remove the center grill grates by using the Grate Tool. Stack grates on the remaining side grates until the fire has been established to keep the grates out of the intense start up fire heat, and to create working space.



2. Using the Ash Shovel, remove about 2/3rds of the fly ash. Move ash and any live coals along the back-center of the fire box. The coals and ash will help start the new fire faster.

LUMP CHARCOAL ONLY FIRE

3. Stack recommended quantity of charcoal (see table above) on top of any live coals and ash toward the back of the firebox. Ignite a fire starter and place it under the charcoal. After 1 hour, add charcoal as necessary to maintain the coal bed depth.

Lump charcoal quantities to fill charbroiler firebox

Model	Lump Charcoal (lbs)
SFB-6	15–20
SFB-6N	15–20



LUMP CHARCOAL AND WOOD FIRE

4. Stack 3 or 4 small pieces of wood in a conical tepee shape on top of any live coals towards the back of the fire box. Ignite a fire starter and place it under the wood.

5. As the wood fire gets going, add lump charcoal in front of the fire—do not extinguish the flame. The lump charcoal will help to quickly establish a good working coal bed.

Note: Without an optional rotisserie, the wood is primarily for theater, and will not be the primary source of live coals.



The well maintained firebox (side view)

The coal bed should be about 3" deep in the back and 1-1/2" in the front. A 5–10" open flame (as measured from the top of coal bed) will maintain this coal depth, producing the temperature regions shown below.

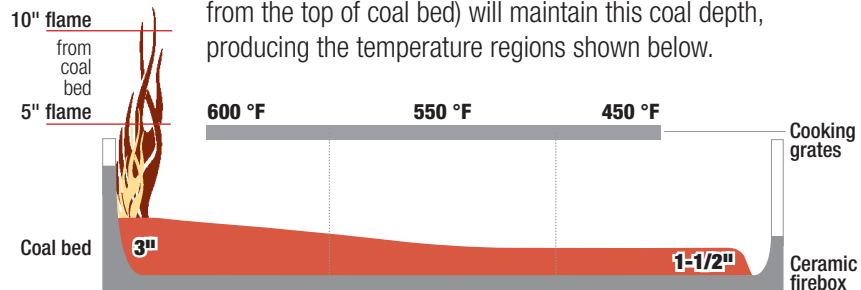



6. Once the fire is well established use the Grate Tool to distribute the coals in the firebox, with about 3" deep in the back, tapering to 1-1/2" deep in the front.

MAINTAINING THE FIREBOX



7. Place two medium pieces of wood on either side of the center flame every 20–30 minutes. The height of the open flame, 5–10 inches as measured from the top of the coal bed, controls the amount of live coals generated, and by extension, the temperature. As necessary, add charcoal to maintain coal bed level, remembering it takes about 15–30 minutes for charcoal to ignite and significantly contribute to the coal bed. Proper firebox maintenance requires taking this delay into account to optimize temperature consistency and minimize over firing.



8. To optimize heat and energy, pull live coals forward out of the fire. Do not pull wood with open flame forward. Cooking over an open flame tends to burn fat, making food taste bitter.

See Fuel Tips below, and the FUELWOOD FACTS section at the end of this manual, for more information about fuel characteristics.

FUEL TIPS

LUMP CHARCOAL

Lump charcoal (we recommend Mesquite lump charcoal) is a carefully produced carbonized product that burns at a higher temperature for a longer period of time than live coals resulting from a natural wood fire. Using lump charcoal as the main source of heat simplifies grill temperature management and is often the only fuel used when kitchen theater isn't a consideration.

WOOD QUALITY

Wood that is not properly dried and sized is the most common operational problem with solid fuel cooking equipment.

The best woods for cooking are heavy hardwoods (Oak, Apple, Hickory, Pecan and Mesquite), with an average length of 16–18", and diameter of 3–5" (either full logs or the sides of split wood). Hardwoods are preferred because they produce more BTU/hr and they coal better, requiring less labor to maintain the same amount of heat.

Ideal moisture levels fall between 15–20%. Accurate moisture readings are taken from the **center** of a freshly split piece of wood. Wood should be kept in a covered area, but not totally enclosed (follow the recommendations in NFPA 96 for safe wood storage and handling practices).

Note: Wood at higher moisture levels produces more creosote residue, which accumulates on the flue lining and exhaust hood, increasing the risk of fire.

BUYING WOOD

Because most wood is sold for heating, it is often only cured for 4–8 months, rather than the 12–16 months required for cooking. It is important to make certain the wood you buy has been cured for cooking. Indicators of high moisture content include hissing (20–25% moisture level), or bubbles forming out the end (moisture higher than 25%). Wood Stone offers an optional Mini-Ligno E Wood Moisture Meter (see the Tools & Accessories section of woodstone-corp.com).



WOOD

Use only well seasoned hardwood to fuel the charbroiler. The wood should have a moisture content of less than 20%. For best results, pieces should be split so that the diameter does not exceed 5 inches. See Wood Stone's FUELWOOD FACTS section at the end of this manual.

CAUTION: NEVER USE GASOLINE, GASOLINE-TYPE LANTERN FUEL, KEROSENE, CHARCOAL LIGHTER FLUID OR SIMILAR LIQUIDS TO START OR FRESHEN-UP A FIRE IN THIS OVEN. KEEP ALL SUCH LIQUIDS WELL AWAY FROM THE OVEN WHEN IN USE.

WOOD STORAGE

Wood should be stored and handled in accordance with the recommendations outlined in NFPA 96.

DISPOSAL OF ASHES

Ashes should be placed in a metal container with a tight-fitting lid. The closed container of ashes should be placed on a non-combustible floor or on the ground, well away from the combustible materials, pending final disposal. When the ashes are disposed by burial in soil or otherwise locally dispersed, they should be retained in the closed container until all cinders have thoroughly cooled.

The optional Wood Stone's Dual Compartment Ash Dolly is available through your dealer. The specification sheet may be viewed on the Wood Stone website under Tools & Accessories.



Wood Stone's optional Double Compartment Ash Dolly. View the spec sheet at woodstone-corp.com in the Tools and Accessories section.



BEGINNING OF DAY

FUEL THE BROILER

Make certain the ventilation system is turned on and operating properly. See FUELING THE CHARBROILER section for details.

LOADING THE ROTISSERIE

Open both doors to load the rotisserie. The drum will stop automatically anytime the doors are opened. To advance the rotisserie drum with the doors open, simply depress the **GREEN** start rotation button to jog the drum. Release the switch when the rotisserie drum reaches the desired position and it will stop.

NEVER ATTEMPT TO PLACE OR REMOVE SPITS WHEN THE ROTISSERIE DRUM IS MOVING

LOADING THE SPITS EVENLY

The spits can only be inserted into the rotisserie drive one way. When loading the rotisserie, make sure the load is evenly distributed by loading equally weighted spits and/or baskets opposite each other. The round end of the spit or basket is always inserted first. Push the round end of the spit into the hole until there is clearance to insert and seat the square end into its socket. Be sure to fully seat the spit so that it locks into place and the round end will rotate freely when the drum turns.

SFR-10 CAPACITY

With the 10-spit SFR-10 model, when using all 10 spits, the operational maximum product load will be approximately 6–7 chickens weighing 2.5 lbs each.

To load larger product, it is possible to run the rotisserie with five spits, removing every other spit for balance.

SPIT DIMENSIONS

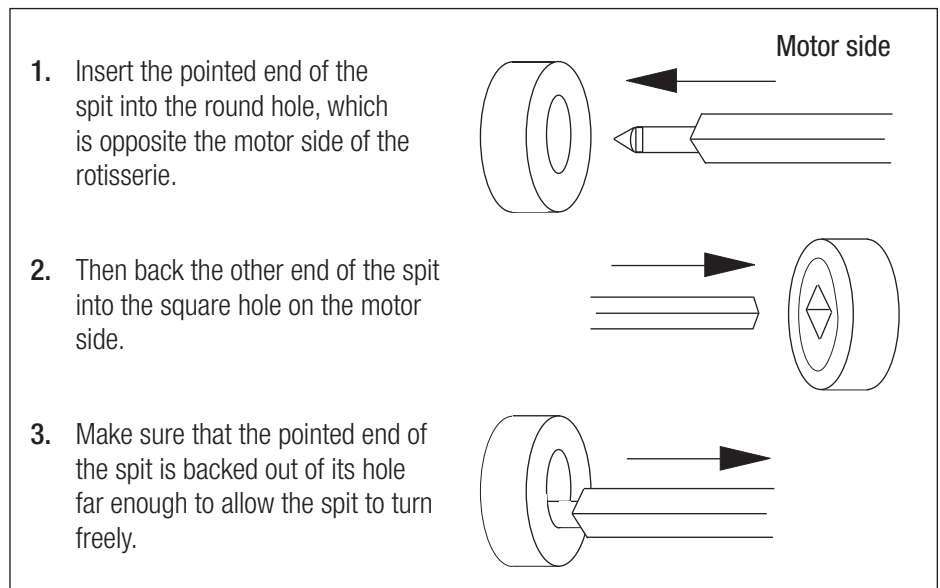
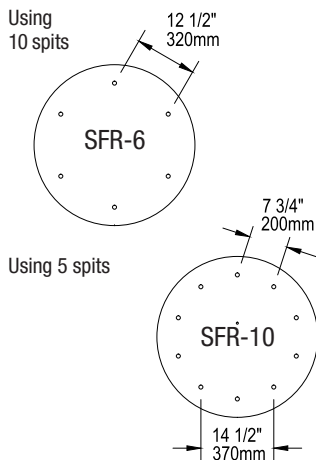

ROTISSERIE OPERATION

To restart the rotisserie, close the doors and push **GREEN** start rotation button. The speed of the rotisserie can be adjusted using the **BLACK** speed control knob located on the controller. The rotisserie will stop anytime the doors are opened or when the **RED** button is depressed.

NOTE: Except during loading or unloading, the drum should always be moving in the presence of heat to avoid warping the rotisserie.

**ROTISSERIE CABINET**

All exposed surfaces of the rotisserie should be wiped clean as necessary (or daily) using an approved mild cleaning solution. Be careful not to get excess liquid into the controller or the main power switch. Stubborn residues may be removed using a non-metallic scouring pad. When scouring stainless steel, scrub with the grain to avoid scratching the finish.

ACCESSORIES

All rotisserie attachments (spits, forks, basket pins) should be cleaned between uses using an approved mild detergent, hot water and an approved sanitizing solution. Alternatively, these items can be cleaned in a dishwasher.

CHARBROILER

If your rotisserie has the extended firebox/charbroiler, scrub the cast iron grill grates (as necessary) with a wire brush to remove cooked-on build-up. The stainless steel grill support rack can be removed and cleaned using hot water and an approved mild detergent.

CERAMIC FIREBOX

Remove excess ash from the firebox using the stainless shovel provided with the rotisserie. **NEVER POUR WATER INTO THE CERAMIC FIREBOX.** We recommend removing excess ash in the morning, after the fire has died down through the night.

ROTISSERIE CABINET FLOOR

Perform cleaning while the rotisserie is still hot, being careful of the resultant steam. Make certain the drain valve is open. Begin by rubbing down the rotisserie bar with a soapy towel. Keep the GREEN rotation button depressed so the drum continues to turn. Then wipe the cabinet floor, directing the soapy water and grease down the grease trough, out the drain and into the grease drip container. Rinse with clean water.

GREASE CONTAINER

Below the loading doors, you will find the grease drip container on casters (this should be checked frequently). There is a brass valve that shuts off the flow of grease from the cabinet. The valve must be closed in order to remove the grease drip container. Be sure to remember to re-open the valve after the container has been cleaned and put back into its place.

EXHAUST HOOD

Refer to the exhaust hood manufacturer's recommendations for inspection, maintenance and cleaning.

CREOSOTE: FORMATION AND NEED FOR REMOVAL

Creosote should be removed to reduce risk of fire. When wood is burned slowly, it produces tar and other organic vapors that combine with expelled moisture to form creosote. The creosote vapors condense in a relatively cool oven flue and exhaust hood of a slow burning fire. As a result, creosote residue accumulates on the flue lining and exhaust hood. When ignited, the creosote makes an extremely hot fire. The oven flue should be inspected twice monthly to determine when creosote build up has occurred. When creosote has accumulated, it should be removed to reduce risk of fire.



A. STANDARD ANGLE SPIT

This is the standard spit included with all Wood Stone Rotisseries. 6 to 7 average sized birds can be quickly loaded. The perforations are convenient for securing the string or skewers used to bind the legs.

B. SQUARE SPIT WITH ADJUSTABLE FORKS

This spit is made of half inch square stock stainless steel and comes with 5 double forks and two end forks. The spit is easy to load and the forks hold the birds in place so that no binding of the legs is required. This spit holds from 1 to 6 birds of various sizes.

C. CLAMSHELL BASKET

This versatile basket spit is constructed of heavy gauge stainless steel and conveniently adjusts to hold a variety of products, ranging from fresh vegetables to two entire Prime Ribs. Stainless steel screens are also available to help secure smaller items.

D. RIB/FISH BASKET SPITS

These are perhaps the most carefully engineered rotisserie spits ever created. This spit is available in a 4-arm, 8 compartment version, or in a 3-arm, 6 compartment version. Each compartment is suitable for a full rack of ribs, a sizeable salmon fillet or several smaller cuts of meat. On the 3-arm, 6 compartment spit the size of each compartment is increased making it ideal for larger items such as Tri-Tip roasts and pork loins. The laser-cut containment flap is spring-loaded for easy loading and unloading.

E. PIG SPIT ASSEMBLY

This unit features a spit made from 1/2-inch square type 304 stainless steel stock. The assembly includes the spit, stainless steel end forks, and an aluminum back brace. The Pig Spit Assembly is suitable for roasting a 30-40 pound suckling pig or lamb.

F. MULTI-SKEWER DRUM ASSEMBLY

The Multi-Skewer Drum Assembly is for use with the Okanogan Single-Spit Rotisserie. The MSDA increases capacity on the rotisserie from 3-4 chickens to 12-16 chickens at a time making your broiler with single-spit rotisserie a powerful production unit.

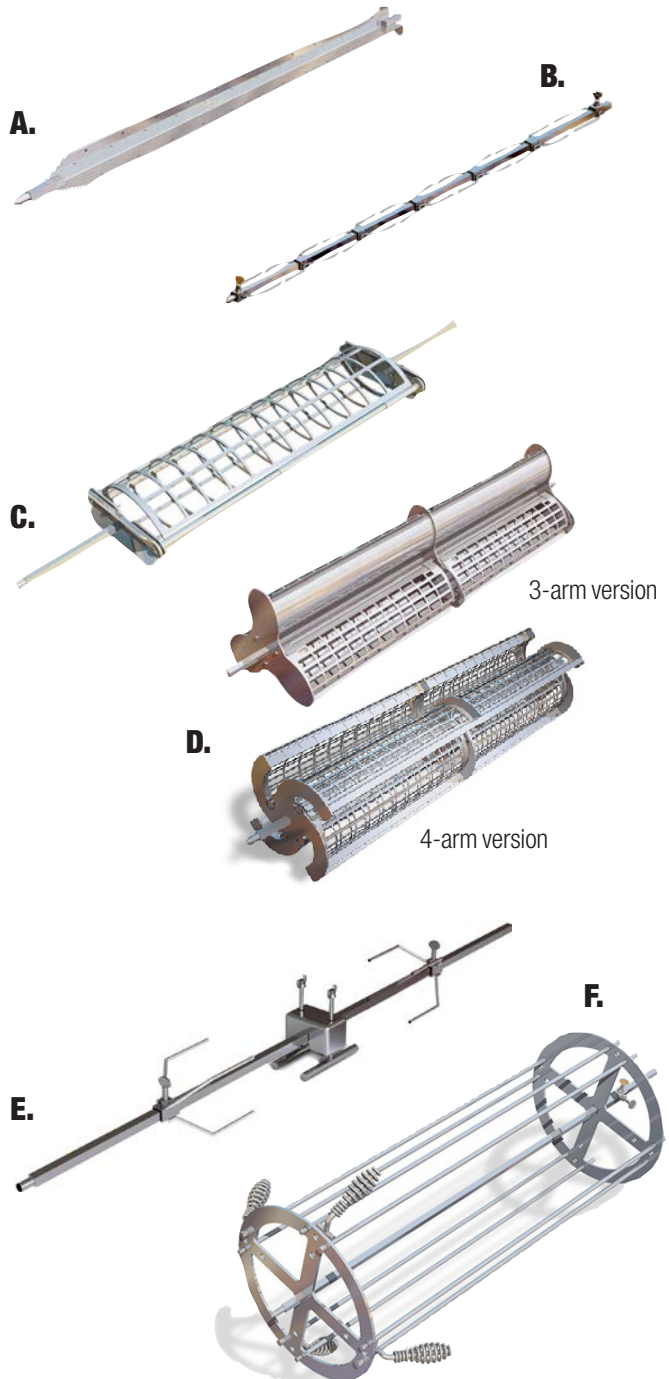

See our Tools & Accessories catalog for additional options.



Contact the Wood Stone Service Department or a qualified local service company for any maintenance or repairs.

NOTE: ALWAYS DISCONNECT POWER SUPPLY BEFORE SERVICING THIS APPLIANCE.

MAIN BEARING LUBRICATION (EVERY 12 MONTHS)

The two main shaft bearings should receive one pump of a NLGI Grade 2 lithium-based grease, such as Lubriplate 630-2, every 12 months. These bearings are located inside the cabinet on either end of the main shaft. A Zerk fitting for each bearing is located directly below the top door hinge on either side of the cabinet on the operator (door) side. Care should be taken not to over lubricate these bearings. One pump is sufficient.

MOTOR BRUSHES REPLACEMENT (APPROXIMATELY EVERY 3 YEARS)

The three year replacement recommendation is based upon an average daily use of 10 hours. Contact the Wood Stone Service Department or your local service technician for service.

REDUCTION GEAR LUBRICATION

The gearbox is permanently lubricated and requires no additional maintenance.

SPUR GEAR BUSHING

Check the spur gear bushings for signs of binding or lateral movement where the gear shank passes through the drive end drum. The gear should rotate in the Rulon inner bushing. If the gear and Rulon bushing are rotating in the drum sleeve instead, remove the gears and Rulon bushings, clean and refit. Do not lubricate the bushings or gears. To remove the gears, first mark the drum in relation to the shaft to ensure it is reinstalled in the same position. Remove the six bolts that retain the drum end to the hub and slide the drum end assembly toward the center of the cabinet. The spur gears can now be removed by loosening the set screw retaining the locking collar and sliding the gears out of the drum.

INNER DRUM SEALING

The condition of the high-temperature sealant used to seal the inner drums to the cabinet walls and the inside corners of the cabinet should be checked and renewed if sealant has failed. Use Dow Corning 732 RTV sealant.

DOOR JAMB MICRO SWITCH

Check the jamb switch for proper operation. The switch should move freely in the jamb without sticking or binding and the drums should stop when the doors are opened.

SPEED CONTROL KNOB

Check the speed control potentiometer for proper operation and the knob for tightness.

DOOR LATCH

Check the door latch mechanism for proper operation. If sticking occurs, remove the wedge pin, clean, refit and adjust.

EXHAUST HOOD

Refer to the exhaust hood manufacturer's recommendations for inspection, maintenance and cleaning.



WHAT TYPE OF WOOD SHOULD YOU USE TO FIRE YOUR SOLID FUEL COOKING EQUIPMENT?

The answer to this question depends on several considerations: geographical location, availability and relative cost of various fuelwood species and individual preferences regarding the flavor qualities of various wood types. There are a wide variety of good fuelwood species in all geographic locations. Each species of wood has different characteristics. The table below should help weigh the pros and cons of various types of wood. Wood from conifers (pine trees) is not recommended due to its poor fuelwood characteristics (low weight, low-med heat, poor coaling, high sparking and high residual creosote).

Wood Type	Heat	Lb/Cord	Lighting	Coaling	Sparks	Fragrance*
Alder	Med-Low	2500	Fair	Good	Moderate	Slight
Apple	High-Med	4400	Fair	Excellent	Few	Excellent
Ash	High	3500	Fairly Difficult	Good-Excellent	Few	Slight
Beech	High	3800	Difficult	Excellent	Few	Good
Birch (white)	Medium	3000	Easy	Good	Moderate	Slight
Cherry	Medium	2000	Fair	Excellent	Few	Excellent
Elm	High	2300	Very Difficult	Good	Very Few	Fair
Hickory	Very High	4200	Fairly Difficult	Excellent	Moderate	Excellent
Maple (red)	High-Med	3200	Fairly Difficult	Excellent	Few	Good
Maple (sugar)	High	3700	Difficult	Excellent	Few	Good
Mesquite	Very High		Very Difficult	Excellent	Many	Excellent
Oak (live)	Very High	4600	Very Difficult	Excellent	Few	Fair
Oak (red)	High	3700	Difficult	Excellent	Few	Fair
Oak (white)	Very High	4200	Fairly Difficult	Excellent	Few	Fair
Pecan	High		Fair	Good	Few	Good

*The desirability of various fragrances is largely a matter of personal preference.

Whichever type of wood you use, **MAKE SURE YOU KNOW THE MOISTURE CONTENT.** Properly seasoned wood contains 20% moisture or less. If wood contains more than 20% moisture, it should not be accepted for use. Wood should be stored off the ground and out of the rain in an environment that allows good air circulation so that the drying process can continue. Wet wood is the most common operational difficulty associated with wood-fired cooking equipment. Wood Stone's optional Mini-Ligno E Wood Moisture Meter can save you from paying for water when you thought you were paying for wood (see the Tools & Accessories section of woodstone-corp.com, contact your dealer or Wood Stone).

Calculate your approximate monthly, daily and hourly fuel-wood costs using the following formulas:
The cost of well-seasoned hardwood varies greatly with geographical location.

$$\text{Cost per month} = A \times C \quad \text{Cost per day} = \frac{A \times C}{30} \quad \text{Cost per hour} = \frac{\left(\frac{A \times C}{30}\right)}{12 \text{ hr day}}$$

A = Cost/cord (from wood supplier)

B = lb/cord (from above table)

C = Cords/mth (from experience, or call Wood Stone for an estimate)

When burned, a pound of any wood releases approximately 6500 BTU/hr, so it is better to compare the price of wood by the pound rather than by the cord. A full cord of wood measures 4' x 4' x 8' when stacked.

$$\text{Cost per lb} = \frac{A}{B}$$

Do not use pressed wood products in Wood Stone equipment. They may damage the ceramics and void the warranty.



The rotisserie comes with a detachable 7' power cord with NEMA 5-15 plug. Provide a grounded 120 VAC, 15 or 20 A outlet. The cord connector can be found underneath the rotisserie on the control side of the unit.

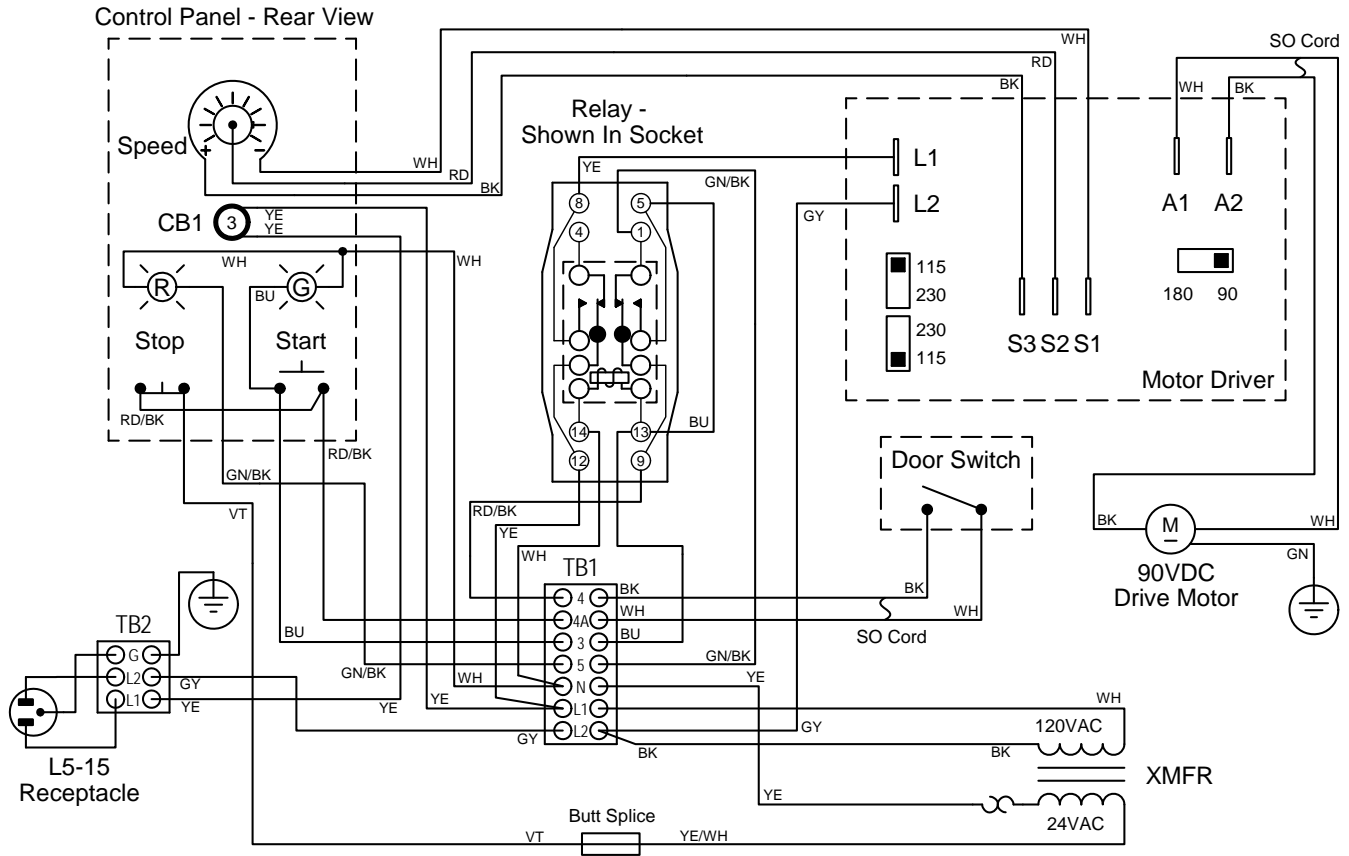



ALL WARRANTY SERVICE MUST BE PRE-APPROVED BY WOOD STONE

Wood Stone warrants its equipment to the original purchaser against defects in material or manufacture for a period of one year from the original date of purchase, subject to the following exclusions and limitations.

Please contact the factory first at 1.800.988.8103 or 1.360.650.1111, seven days a week. Our normal business hours are 8am to 5pm Pacific Time Monday–Friday. If calling during non-business hours, follow the recorded instructions for emergency service and a Wood Stone technician will get back to you promptly.

EXCLUSIONS

The warranties provided by Wood Stone do not apply in the following instances:

1. In the event that the equipment is improperly installed. Proper installation is the responsibility of the installer; proper installation procedures are prescribed by the Wood Stone Installation and Operation Manual.
2. In the event the equipment is improperly or inadequately maintained. Proper maintenance is the responsibility of the user; proper maintenance procedures are prescribed in the Wood Stone Installation and Operation Manual. Burner problems resulting from debris or ash in the burner well will not be covered by the warranty. Call with questions regarding maintenance frequency.
3. In the event that the failure or malfunction of the appliance or any part thereof is caused by abnormal or improper use or is otherwise not attributable to defect in material or manufacture.
4. In the event that the appliance, by whatever cause, has been materially altered from the condition in which it left the factory.
5. In the event that the rating plate has been removed, altered or obliterated.
6. On parts that would be normally worn or replaced under normal conditions.
7. Normal cracking due to expansion and contraction stress relief in the ceramic firebox.
8. In wood-fired equipment configurations, in the event that pressed log products of any type have been burned in the equipment.
9. In coal-fired oven configurations, in the event any type of coal other than anthracite coal fuel has been used.
10. Damage resulting from the use of chemical cleaning products in the oven, as well as any damage from liquids or chemicals, including water, being poured or sprayed into the oven.

If any oral statements have been made regarding this appliance, such statements do not constitute warranties and are not part of the contract of sale. This Limited Warranty constitutes the complete, final and exclusive statement with regard to warranties.

THIS LIMITED WARRANTY IS EXCLUSIVE AND IN LIEU OF ALL OTHER WARRANTIES WHETHER WRITTEN, ORAL OR IMPLIED, INCLUDING, BUT NOT LIMITED TO, ANY WARRANTY OF MERCHANTABILITY OR FITNESS FOR PARTICULAR PURPOSE OR WARRANTY AGAINST LATENT DEFECTS.

LIMITATIONS OF LIABILITY

In the event of warranty claim or otherwise, the sole obligation of Wood Stone shall be the repair and/or replacement, at the option of Wood Stone, of the appliance or component or part thereof. Such repair or replacement shall be at the expense of Wood Stone with the exception of travel over 100 miles or two hours, overtime, and holiday charges which shall be at the expense of the purchaser. Any repair or replacement under this warranty does not constitute an extension of the original warranty for any period of the appliance or for any component or part thereof. Parts to be replaced under this warranty will be repaired or replaced at the option of Wood Stone with new or functionally operative parts. The liability of Wood Stone on any claim of any kind, including claims based on warranty, expressed or implied, contract, negligence, strict liability or any other theories shall be solely and exclusively the repair or replacement of the product as stated herein, and such liability shall not include, and purchaser specifically renounces any rights to recover, special, incidental, consequential or other damages of any kind whatsoever, including, but not limited to, injuries to persons or damage to property, loss of profits or anticipated profits, or loss of use of the product.

TO SECURE WARRANTY SERVICE

If you claim a defect covered by this Limited Warranty, contact:

Wood Stone Corporation, Attn: Service Department, 1801 W. Bakerview Rd., Bellingham, WA 98226 USA
Phone 1.800.988.8103 or 1.360.650.1111

Page left intentionally blank.

Page left intentionally blank.

Wood Stone

WOOD STONE CORPORATION

1801 W. Bakerview Rd.
Bellingham, WA 98226 USA

Toll Free 800.988.8103

Tel 360.650.1111

Fax 360.650.1166

www.woodstone-corp.com

An ongoing program of product improvement may require us to change specifications without notice.