



WS-BL-4355-RFG-TR with chimney shown extended.

### HEARTH CAPACITY

8" pizzas:	9-12
10" pizzas:	9
12" pizzas:	6
16" pizzas:	4
Considered an operational challenge	

*Assuming 5-minute cook times, the approximate maximum hourly production capacity can be calculated by multiplying the above numbers by 12. Cook times will also vary depending on "style" of pizza.*

Job Name	
Model	WS-BL-4355-RFG-TR
Item#	

The Wood Stone Trailered oven is the perfect mobile stone hearth oven solution for catering and special events. This version utilizes our versatile Bistro 4355 oven and features a door opening 24.5 inches wide x 7.5 inches high. The oven floor is 34 inches wide x 39 inches deep, resulting in a 9.2-square-foot cooking surface.

A tensioned steel exoskeleton surrounding the hearth and dome perimeter ensures structural integrity and longevity. Wrapped in spun ceramic fiber insulation and requiring only a 1-inch side clearance to combustibles, the monolithic cast-ceramic hearth and monolithic dome rest on a black painted stand, while the oven body is enclosed with stainless steel and is securely mounted to the trailer.

The Trailered oven runs on propane gas and the trailer comes equipped with four, 30-pound propane tanks, providing enough fuel for approximately 20 hours of typical running time. The oven does require a 120 VAC power source to power the electronics and ignition system.

The Trailered oven vents through a self-contained collapsible chimney assembly, complete with rain cap. Lowering the chimney minimizes wind resistance while traveling, as well as encloses the flue outlet to prevent rain from entering the cooking chamber.

Towing weight is approximately 4,000 pounds and the trailer comes with a 2-15/16-inch ball. A tow vehicle capable of safely pulling 4,000 pounds and equipped with a trailer brake controller is required.

The oven and trailer arrive completely assembled, ETL Listed and are made in the USA.



t. 360.650.1111  
tf. 800.988.8103  
f. 360.650.1166

Wood Stone Corporation  
1801 W. Bakerview Rd.  
Bellingham, WA 98226 USA  
[info@woodstone-corp.com](mailto:info@woodstone-corp.com)  
[woodstone-corp.com](http://woodstone-corp.com)

REVISED: SPRING 2017

An ongoing program of product improvement may require us to change specifications without notice.





# TRAILERED OVEN

## STONE HEARTH OVEN • WS-BL-4355-RFG-TR

Note: Dimensions shown are "as shipped." Due to loading, tire pressure and terrain, these dimensions may vary.

A	Chimney
B	Mantle
C	Flame Height Control Knob
D	Digital Controller
E	Service Panel
F	Propane Tanks
	Must Be Left Removable for Service
1	Trailer Wiring Connector 12 VDC 7-Pin Receptacle for Trailer
2	Power Cord Receptacle 120 VAC, 2 A NEMA 5-15 Plug for Oven
	AIR INTAKE: Do Not Facade or Cover Over

PLAN VIEW

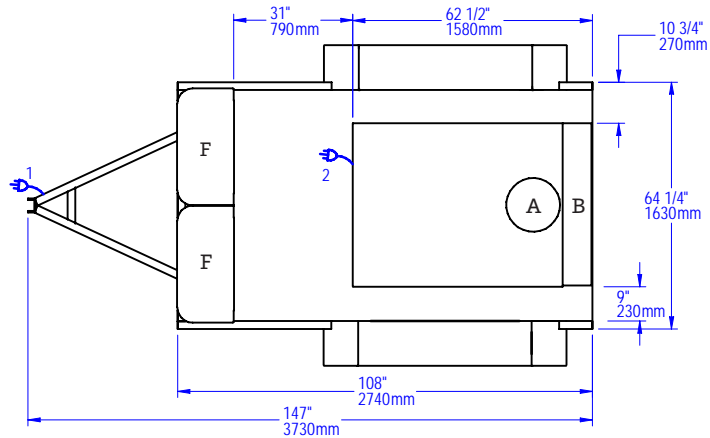

SIDE VIEW

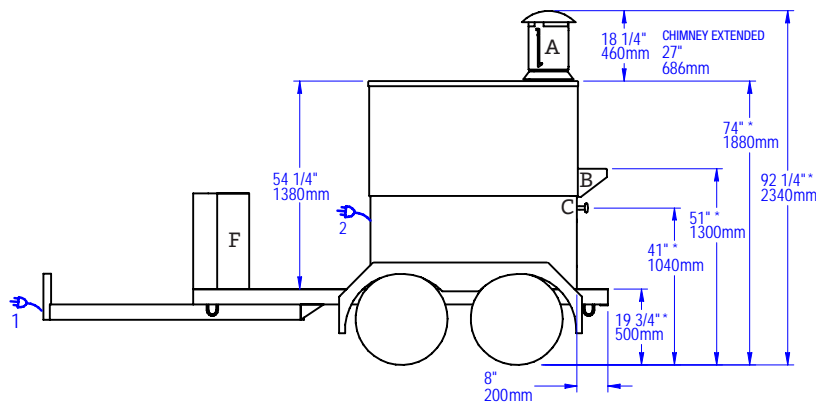

FRONT VIEW

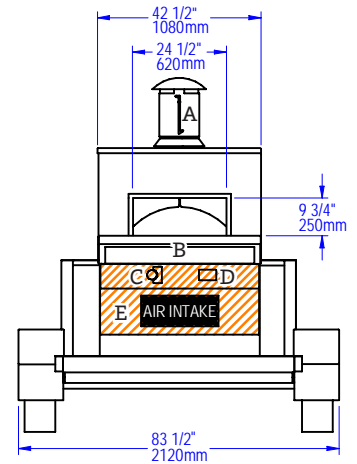

UTILITIES SPECIFICATIONS

**GAS**  
**Gas-Fired Only and Combination**  
 68,000 BTU/hr - Self-Contained  
 Propane (LP) Supply

**ELECTRICAL**  
**Gas-Fired Only and Combination**  
 120 VAC, 2 A NEMA 5-15 plug for oven.  
 Trailer Receptacle: 12 VDC 7-Pin.

VENTING INFORMATION

Self-contained. No additional venting required.  
 For outdoor use only in well ventilated areas.

**Ship Weight: 4,000 lbs / 1,814 kg**



t. 360.650.1111  
 tf. 800.988.8103  
 f. 360.650.1166

Wood Stone Corporation  
 1801 W. Bakerview Rd.  
 Bellingham, WA 98226 USA  
[info@woodstone-corp.com](mailto:info@woodstone-corp.com)  
[woodstone-corp.com](http://woodstone-corp.com)

REVISED: SPRING 2017

An ongoing program of product improvement may require us to change specifications without notice.

