



Copper Powder Coat Finish shown.

FEATURES

- Cooks Like Clay
- Long Lifespan
- Durable Ceramic Interior
- Consistent Reliable Heat
- Custom Finishes Available

Job Name	
Model	WS-GFT-3521-BRL
Item#	

The Wood Stone gas-fired Barrel Tandoor features a cooking chamber that uses the same ultra-strong, high-temperature ceramic technology that we utilize in our stone hearth ovens.

The ceramic cooking chamber has a 12-inch opening and is encased in an eye-catching powder coat finish that is fully insulated. The Tandoor is topped with an attractive and durable quartz composite that simulates the look of black granite. A Naan Hook, Naan Scraper and Skewers are included with the unit.

The gas burner uses a pilot safety valve, equipped with a Piezo-Electric ignition system. The heat output of the burner can be adjusted from its highest setting to completely turned off (or any setting in between) by turning the Flame Height Control Knob, which is located on top of the control box.

The Tandoor comes with a lightweight, ventilated lid for faster heat-up and a Skewer Indexing Ring to support and position skewers. A removable drip/debris pan is located beneath the unit.

Wood Stone Tandoors can be configured to burn Natural Gas or Propane—this should be specified at the time of order.

The Barrel Tandoor is supported by 4 legs which are adjustable to allow for leveling. The adjustable height of the unit on a level floor is 35.25 to 36.25 inches. An adjustable base trim piece is provided to seal the unit to the floor.

Wood Stone Barrel Tandoors arrive completely assembled, ETL Listed, ready to install, and are made in the USA. Information about custom finishes, tools and accessories can be found online at: woodstone-corp.com.



t. 360.650.1111
tf. 800.988.8103
f. 360.650.1166

Wood Stone Corporation
1801 W. Bakerview Rd.
Bellingham, WA 98226 USA
info@woodstone-corp.com
woodstone-corp.com

REVISED: SPRING 2017

An ongoing program of product improvement may require us to change specifications without notice.



BARREL TANDOOR

GAS-FIRED TANDOOR • WS-GFT-3521-BRL

PLAN VIEW

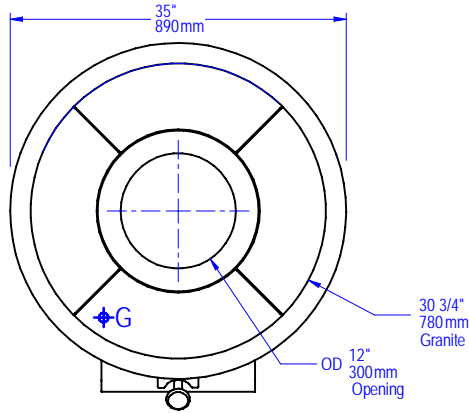

B	Removable Lid
C	Flame Height Control Knob
D	Gas Control Box
G	Gas Connection
	Must Be Left Removable for Service

FRONT VIEW

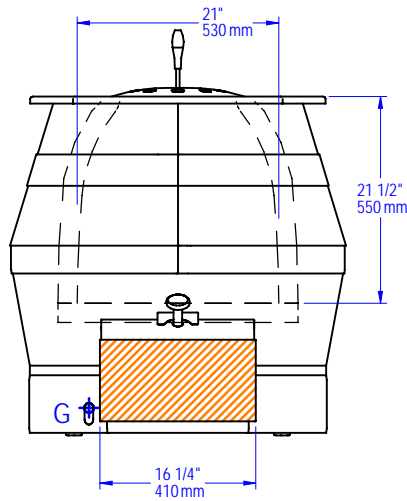

SIDE VIEW

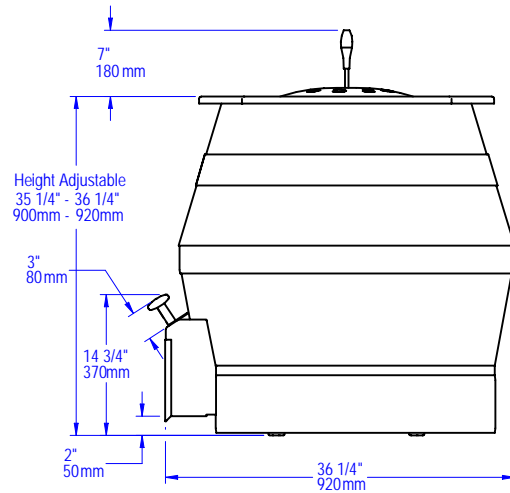

UTILITIES SPECIFICATIONS

GAS
 1/2 inch gas inlet (FNPT)
 40,000 BTU/hr - Natural Gas (NG)
 OR
 40,000 BTU/hr - Propane (LP)
 Connection is made beneath the unit to the left of the gas control box.

Note: Gas type must be specified at time of order.

VENTING INFORMATION

The Barrel Tandoor must be vented with a Listed Type 1 exhaust hood, or one constructed in accordance with NFPA 96 and all relevant local and national codes. The oven must be vented in accordance with all relevant local and national codes, and in a manner acceptable to the authority having jurisdiction.

Ship Weight: 750 lbs / 340 kg



t. 360.650.1111
 tf. 800.988.8103
 f. 360.650.1166

Wood Stone Corporation
 1801 W. Bakerview Rd.
 Bellingham, WA 98226 USA
info@woodstone-corp.com
woodstone-corp.com

REVISED: SPRING 2017

An ongoing program of product improvement may require us to change specifications without notice.

